

Инструкция по сборке

Астрис

Тумба для обуви - 2

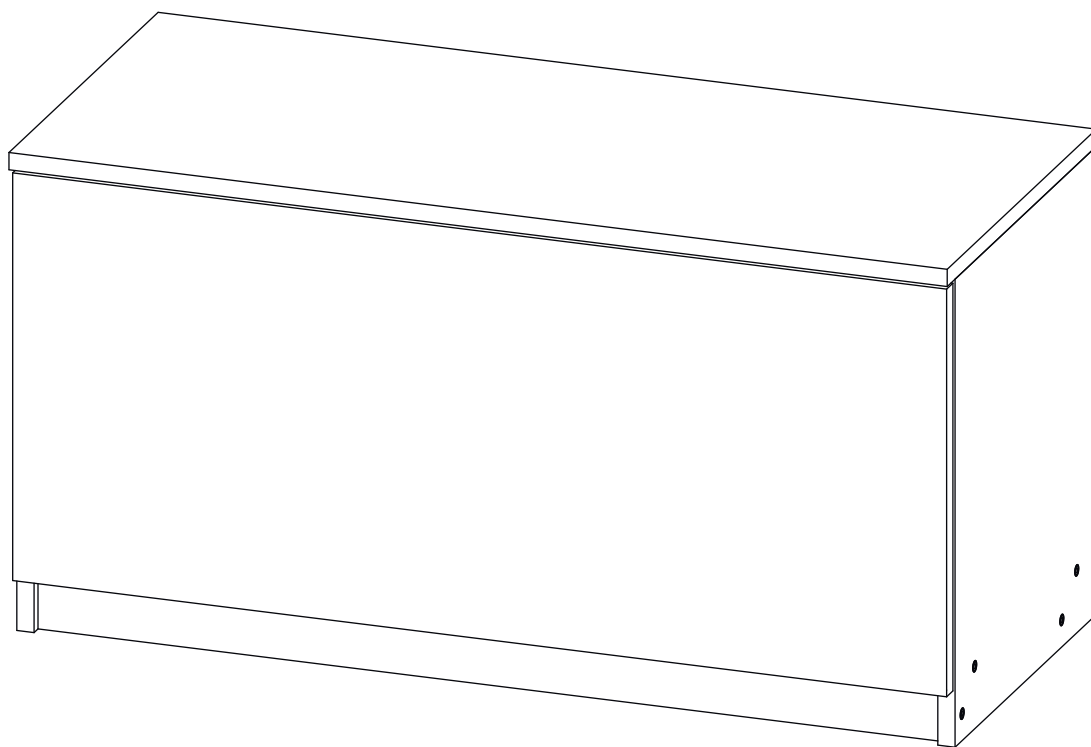

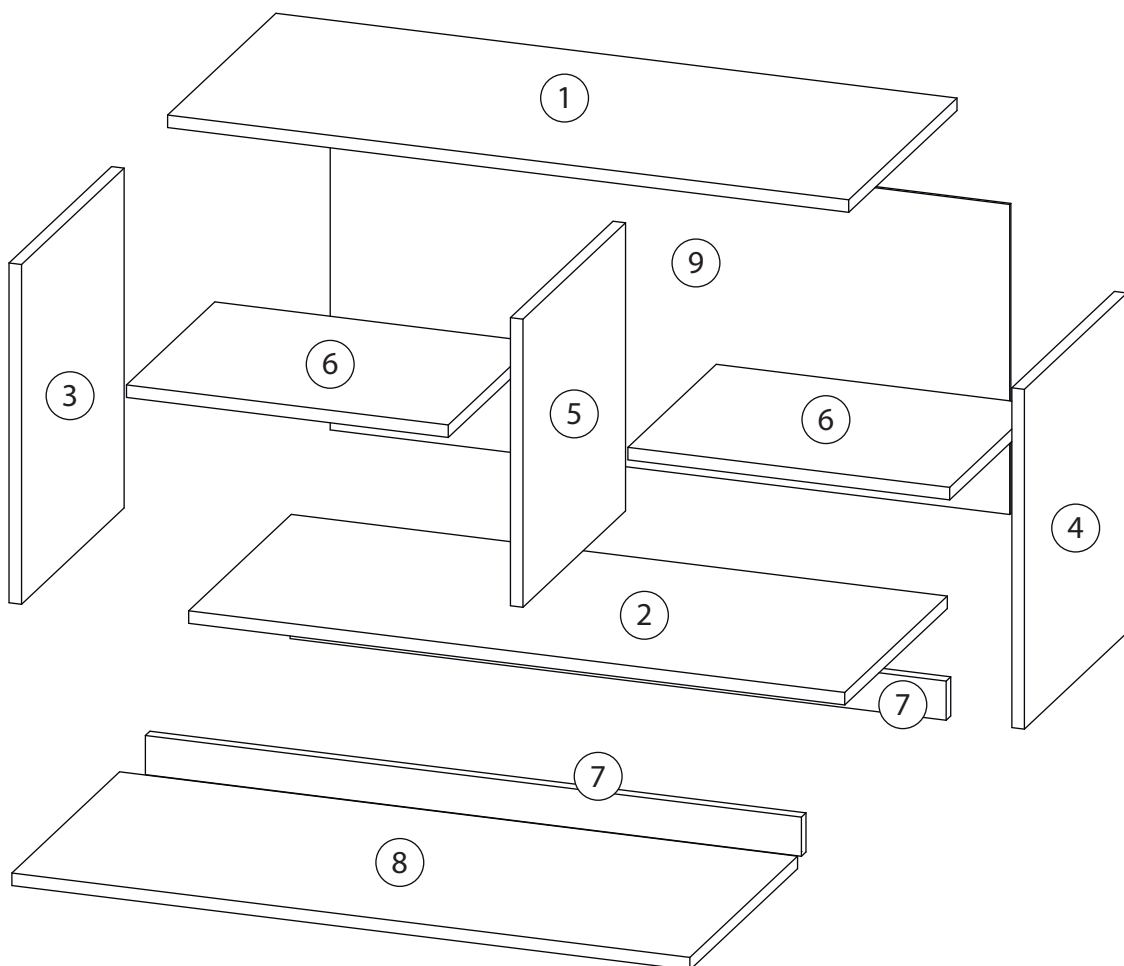

Детали

Поз.	Наименование	Кол-во	Длина	Ширина
1	Крыша	1	870	380
2	Дно	1	838	360
3	Бок левый	1	434	360
4	Бок правый	1	434	360
5	Перегородка	1	368	360
6	Полка	2	411	310
7	Цоколь	2	838	50
8	Фасад	1	378	866
9	Задняя стенка	1	396	868

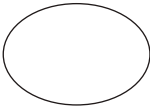
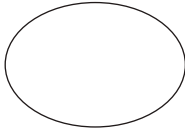
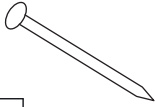
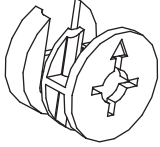

Фурнитура

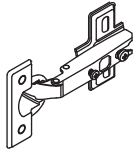
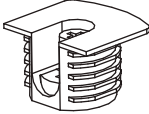
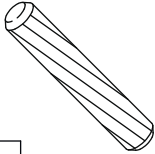
				
10	11	12	13	14
<u>Заглушка</u> <u>Ø13</u>	<u>Заглушка</u> <u>Ø17-20</u>	<u>Гвоздь 1,6x25</u>	<u>Евровинт 7x50</u>	<u>Эксцентрик</u>
				
15	16	17	18	19
<u>Саморез 3,5x16</u>	<u>Петля вкладная</u>	<u>Евровинт 6,3x13</u>	<u>Стяжка VB35</u>	<u>Винт для стяжки</u> <u>VB35</u>
				
20	21			
<u>Шкант бук</u>	<u>Шток эксцентрика</u>			

1

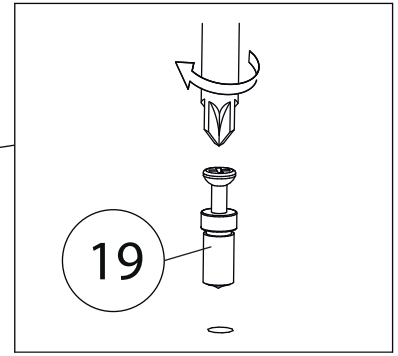
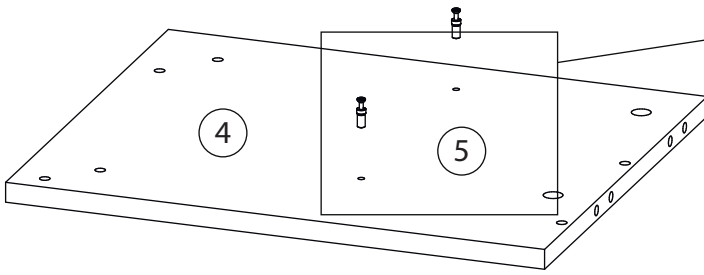

2

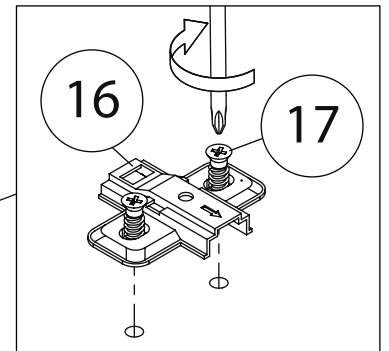
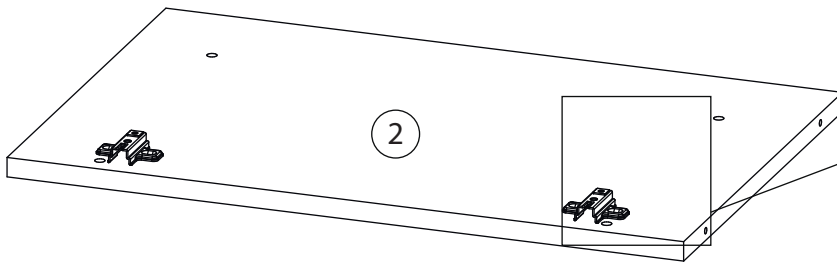

3

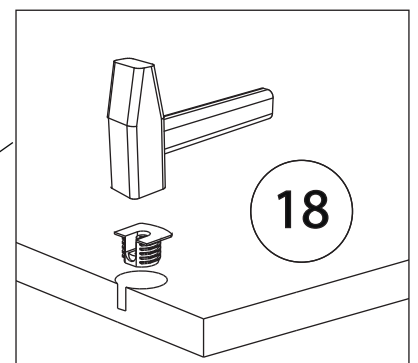
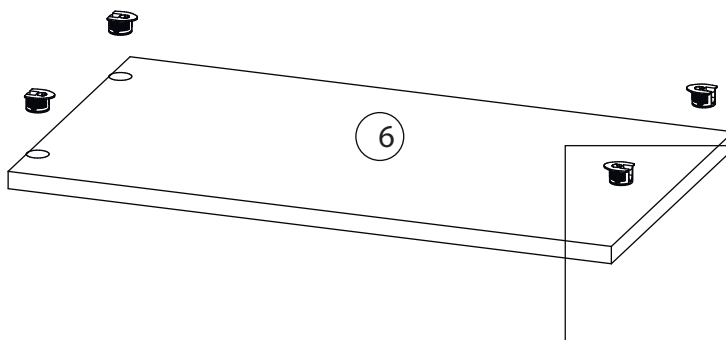

4

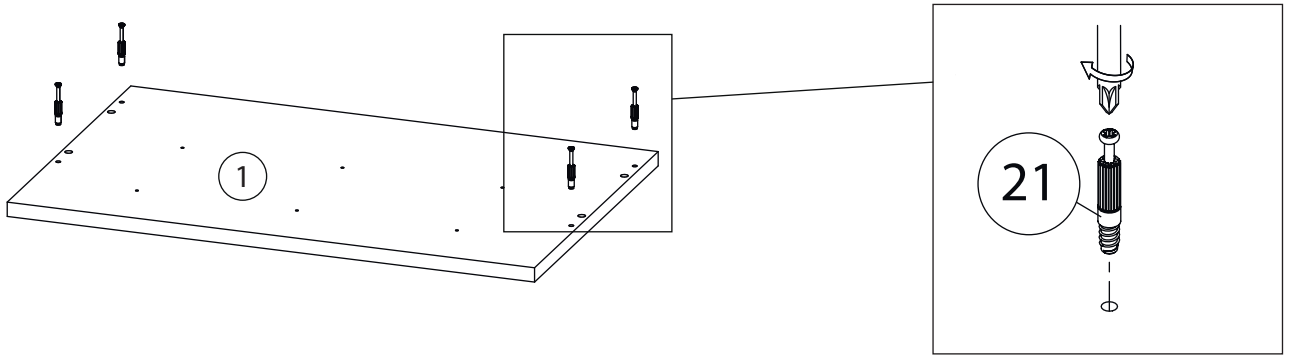

5

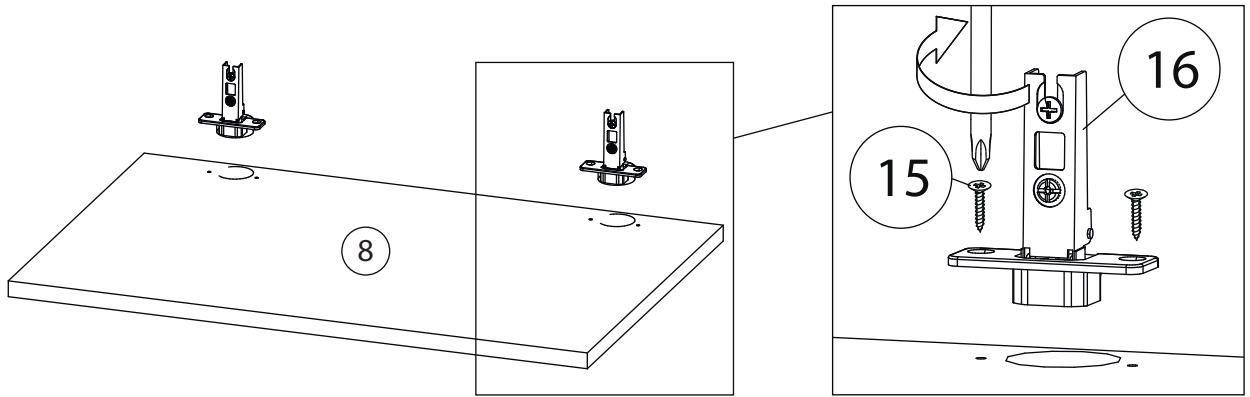

6

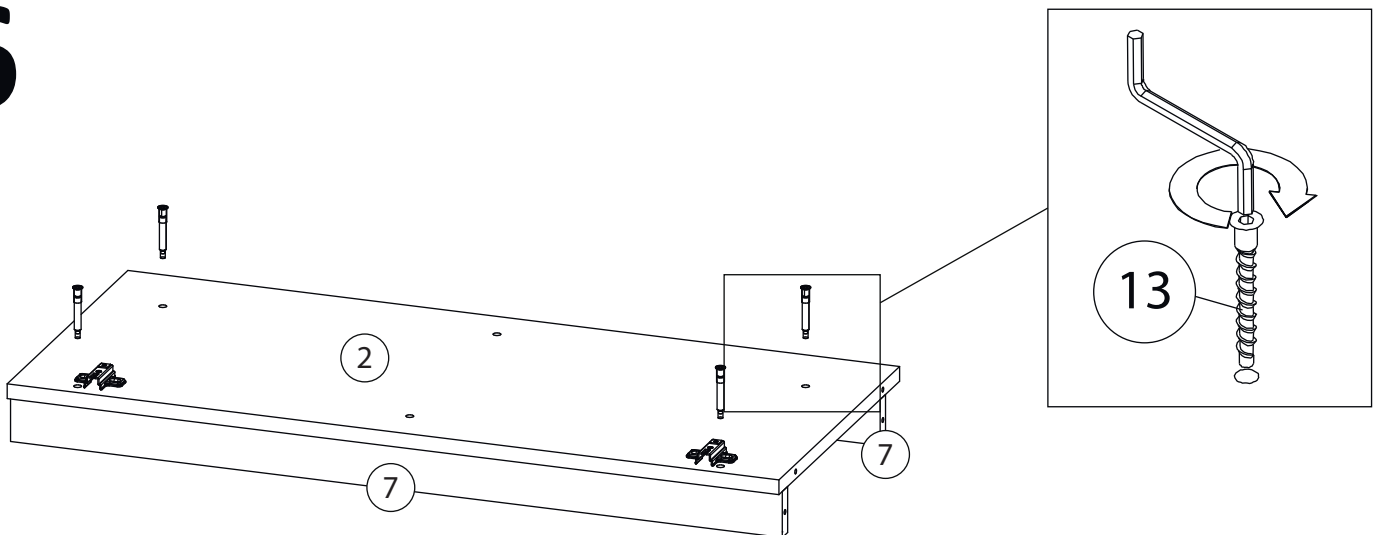

7

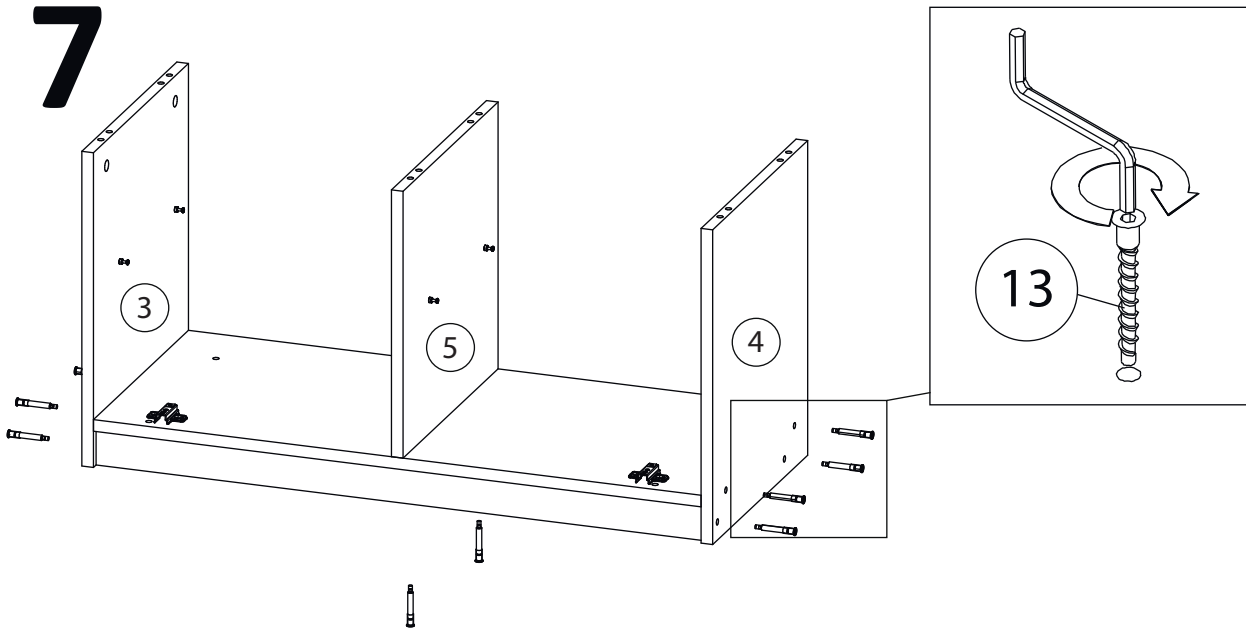

8

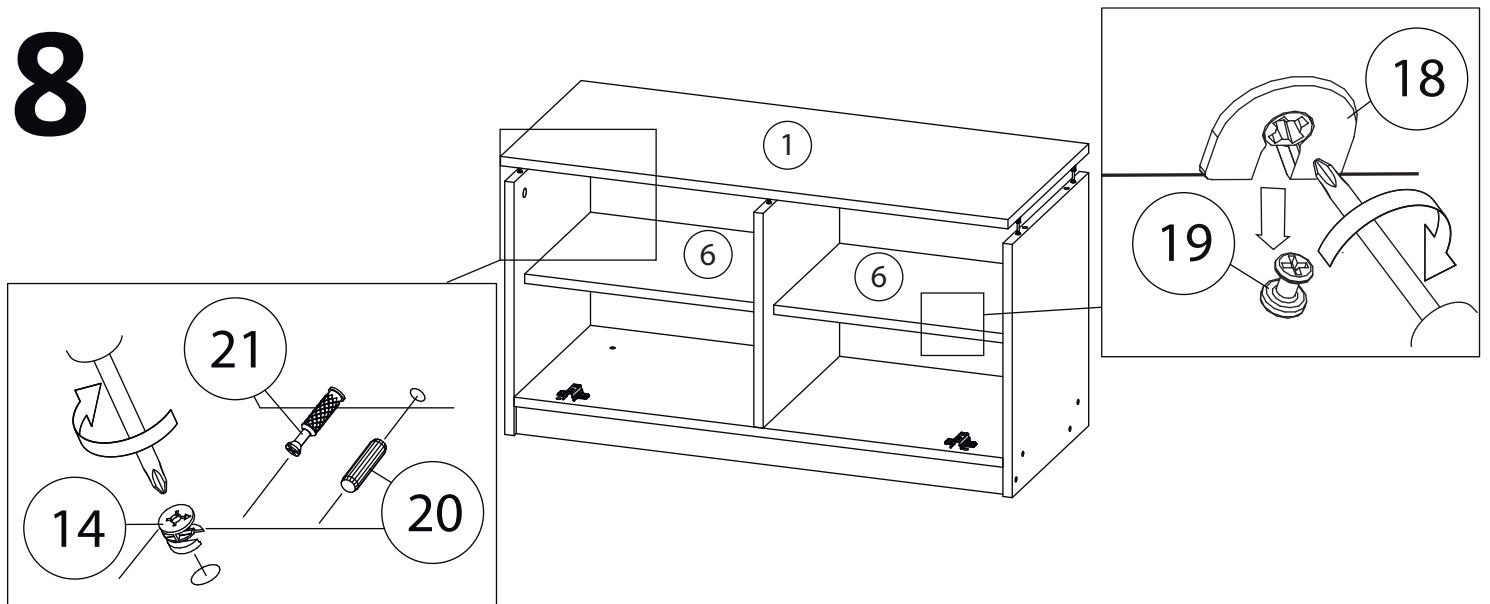

9

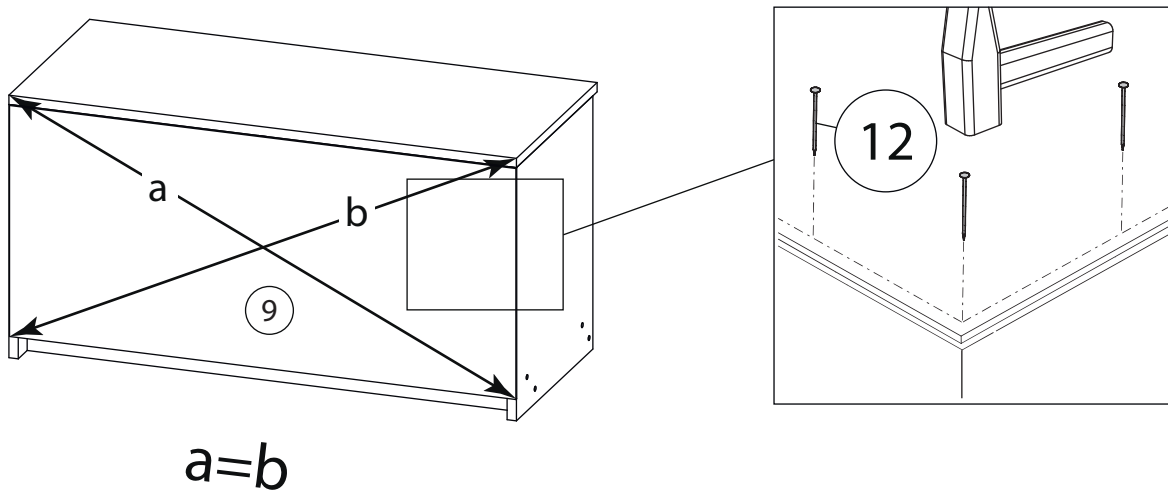

10

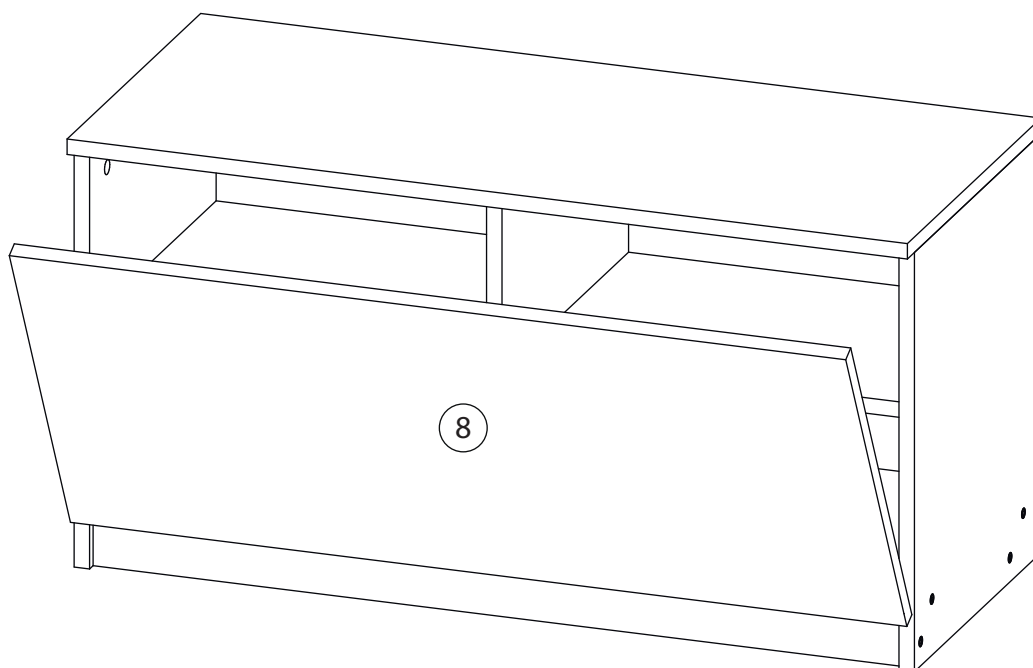
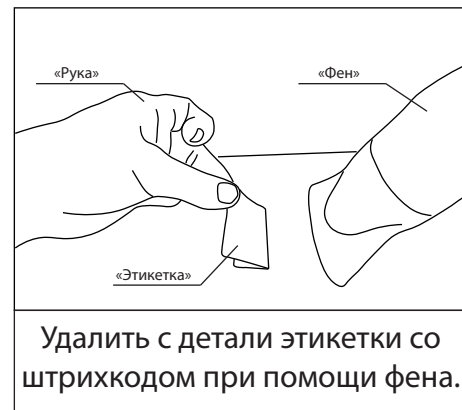
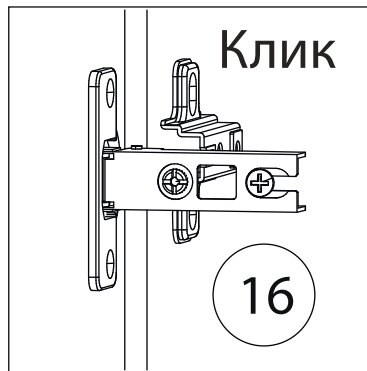

Заклеить технические отверстия заглушками.

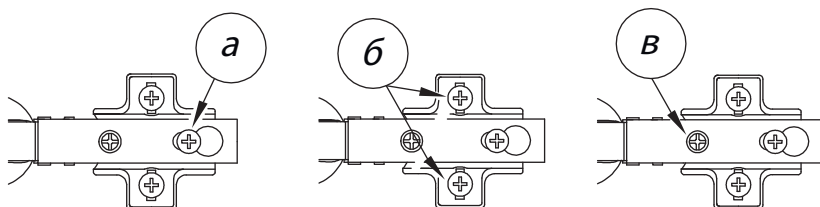

Регулировка петель

а - регулировка расстояния между дверью и корпусом
б - регулировка положения двери по-вертикали
в - регулировка положения ТТдвери по-горизонтالي