

Инструкция по сборке

Тоди

Письменный стол

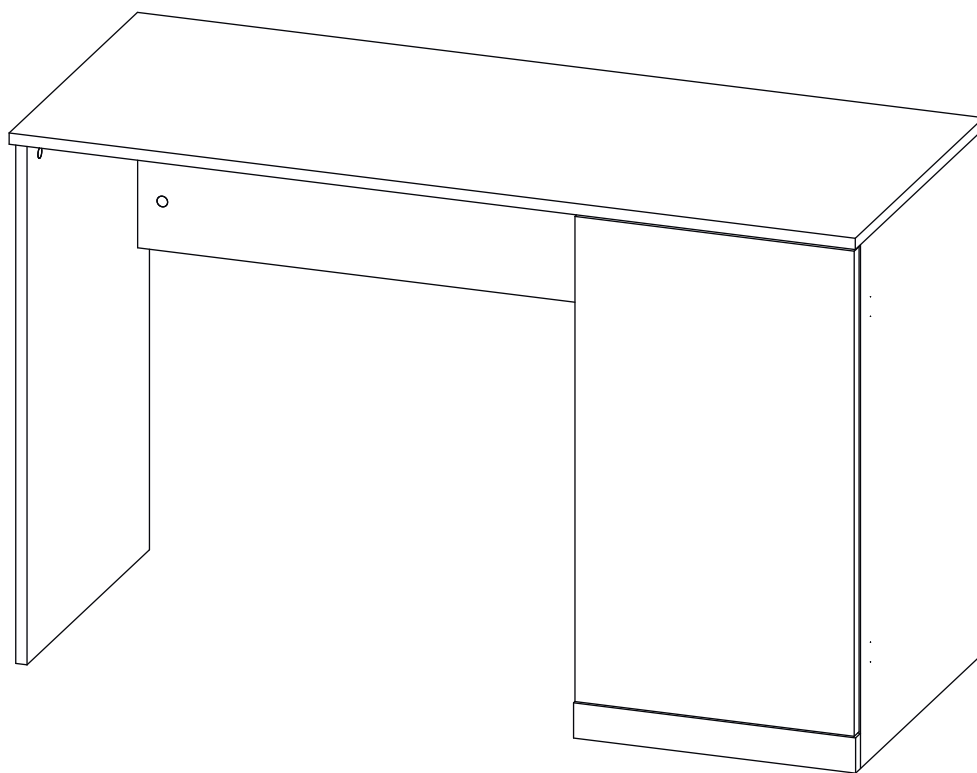



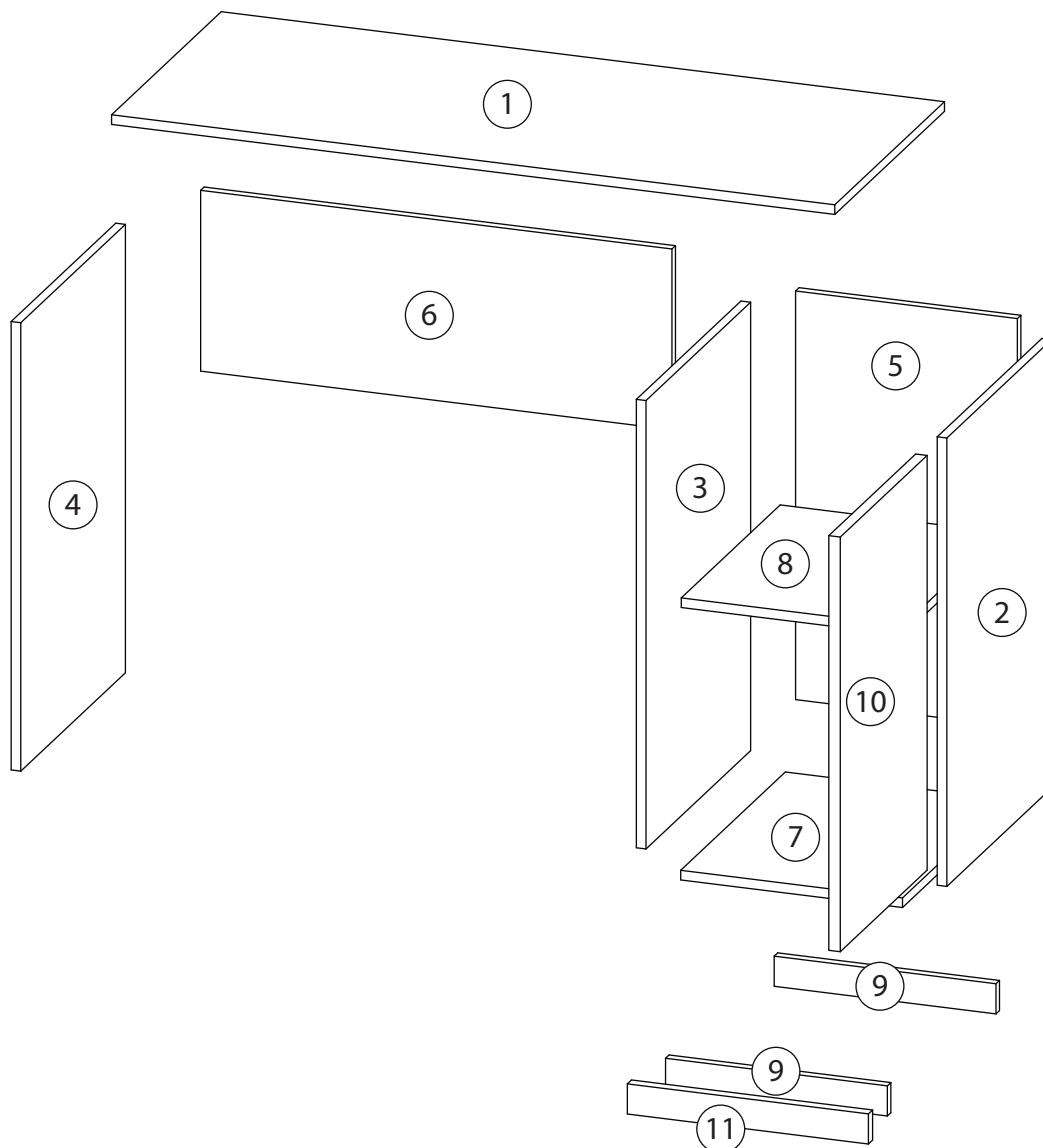

Детали

Поз.	Наименование	Кол-во	Длина	Ширина
1	Столешница	1	1200	500
2	Бок Правый	1	744	477
3	Бок Тумбы Левый	1	744	477
4	Бок Лелый	1	744	477
5	Задняя стенка	1	678	368
6	Ребро жесткости	1	300	782
7	Дно	1	368	477
8	Полка	1	368	451
9	Цоколь	2	368	50
10	Фасад	1	688	396
11	Цоколь	1	400	50

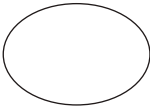
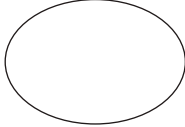
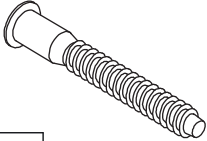

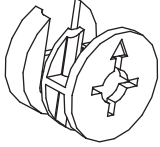
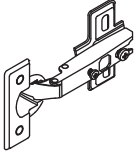
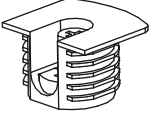
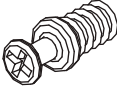
Фурнитура

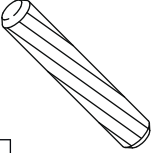
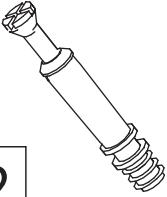
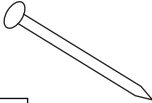
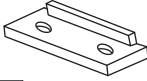
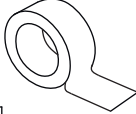
				
12	13	14	15	16
<u>Заглушка</u> Ø13	<u>Заглушка</u> Ø17-20	<u>Евровинт 7x50</u>	<u>Евровинт 6,3x13</u>	<u>Эксцентрик</u>
				
17	18	19	20	21
<u>Петля накладная</u>	<u>Стяжка VB35</u>	<u>Винт для стяжки</u> VB35	<u>Саморез 3,5x16</u>	<u>Шкант бук</u>
				
22	23	24	25	
<u>Шток эксцентрика</u>	<u>Гвоздь 1,6x25</u>	<u>Подпятник</u>	2-х сторонний скотч	

1



2

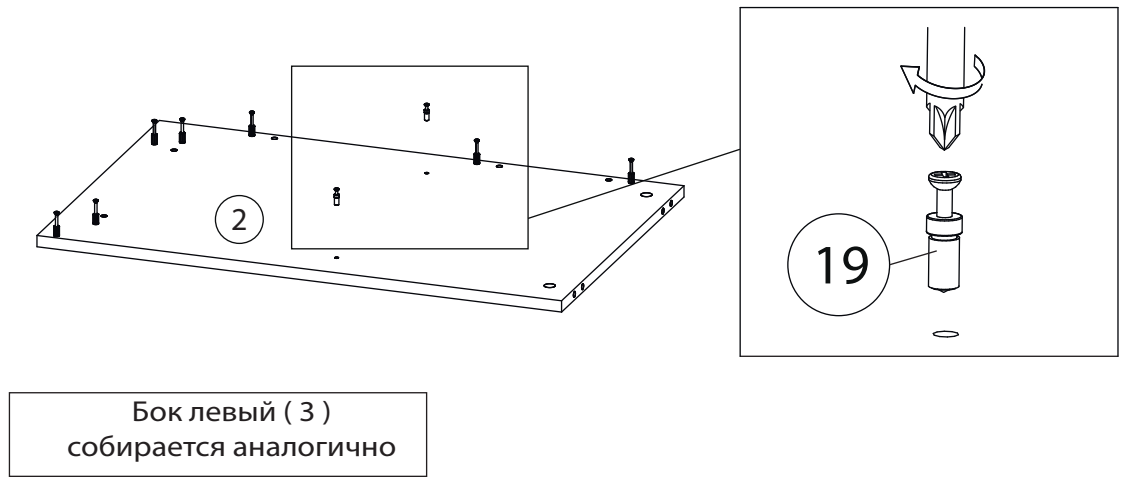

3

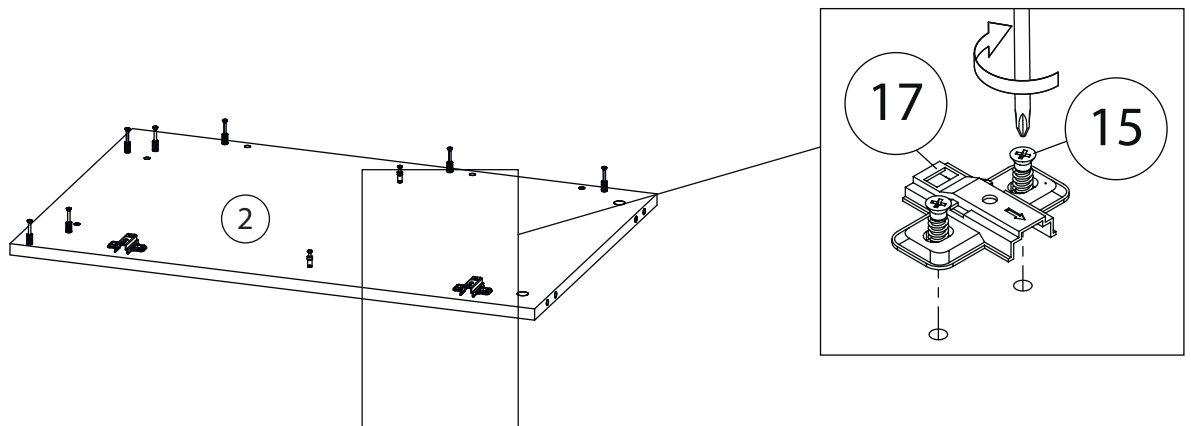

4

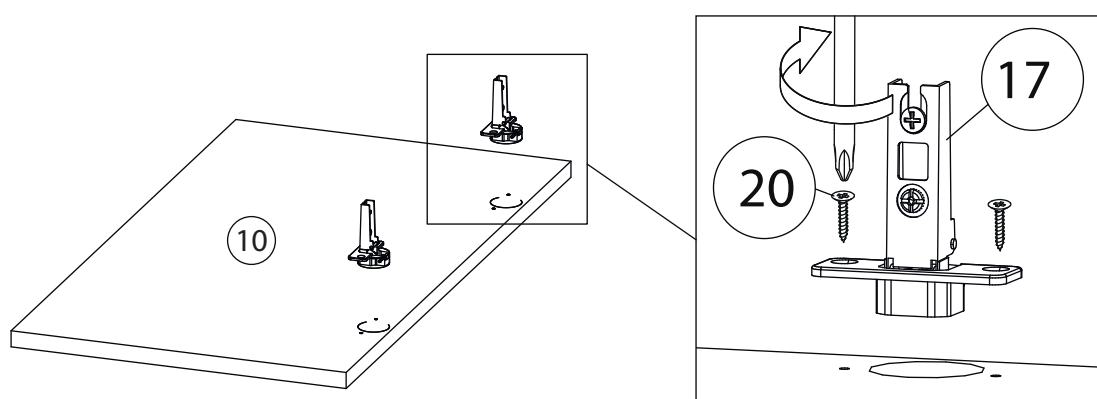
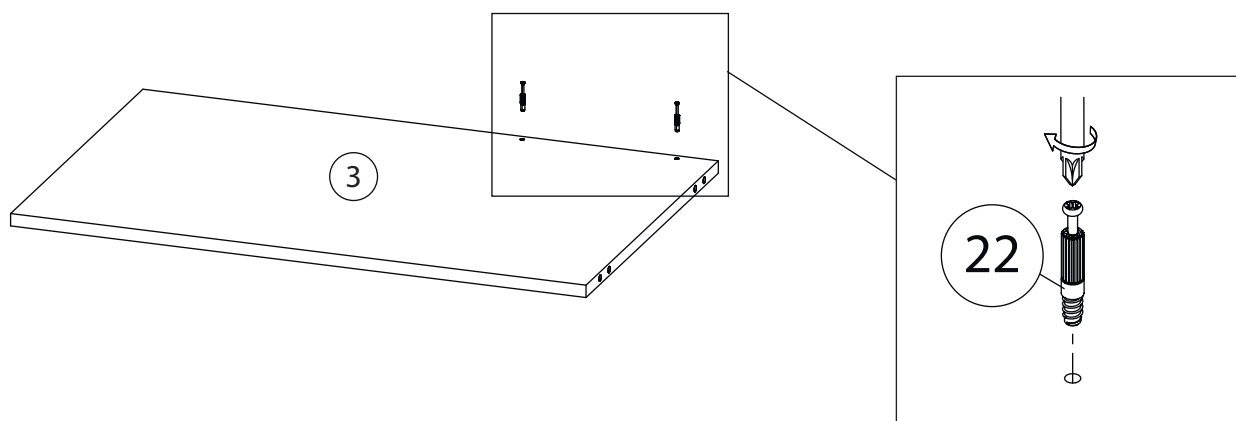

5

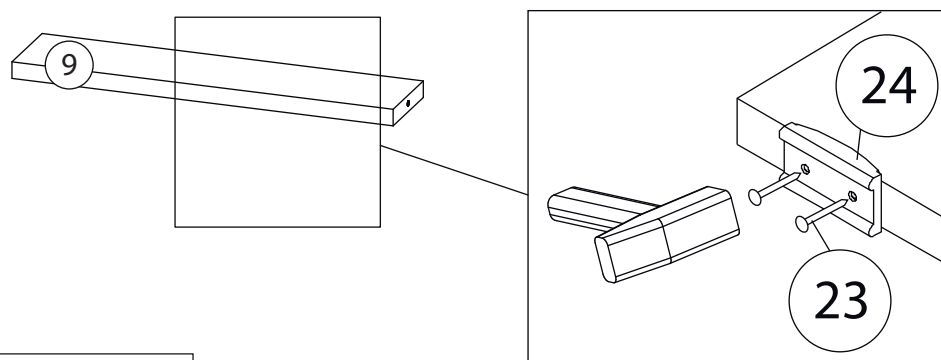

Цоколь (9)
собирается аналогично

7

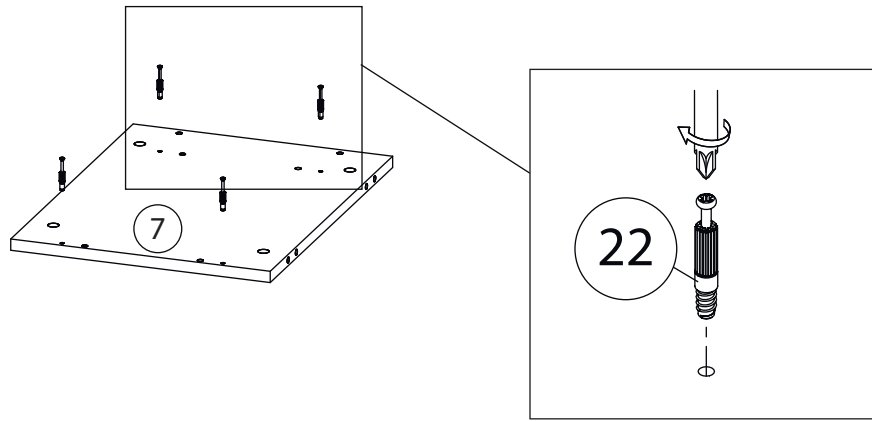

8

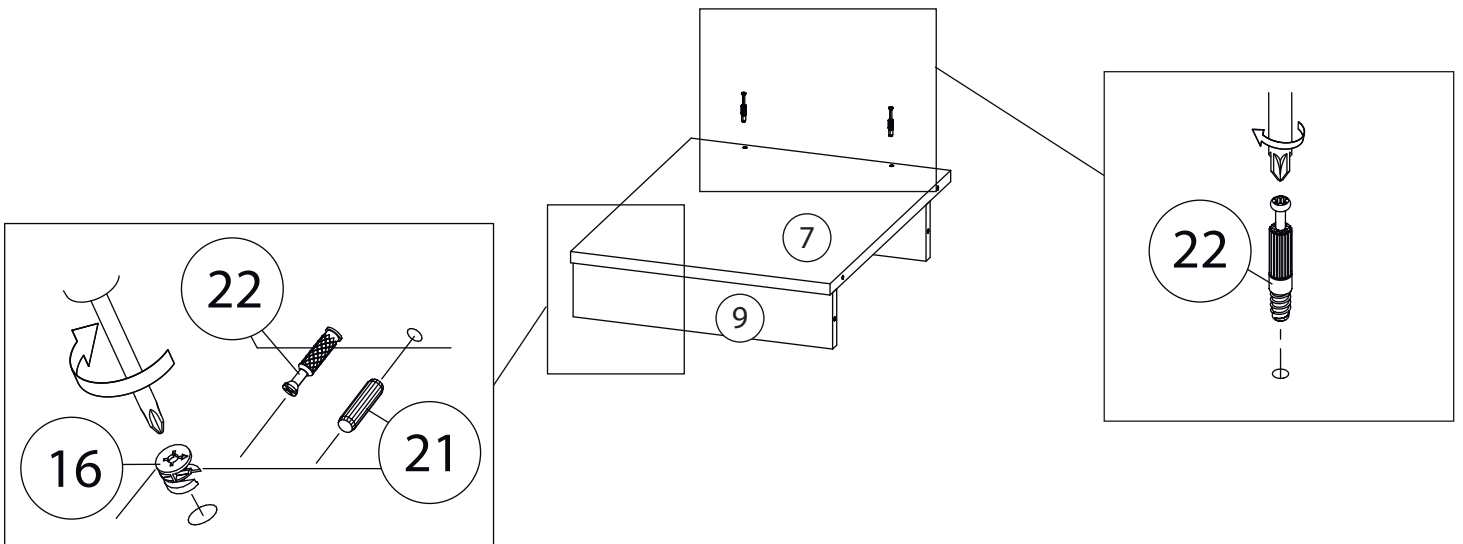

9

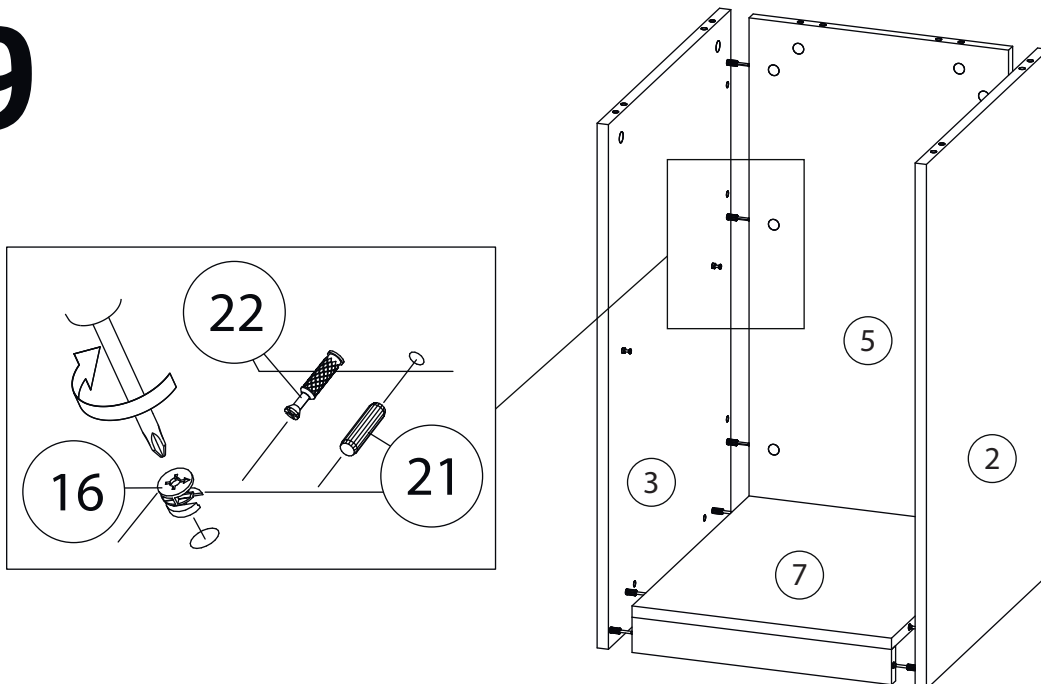

10

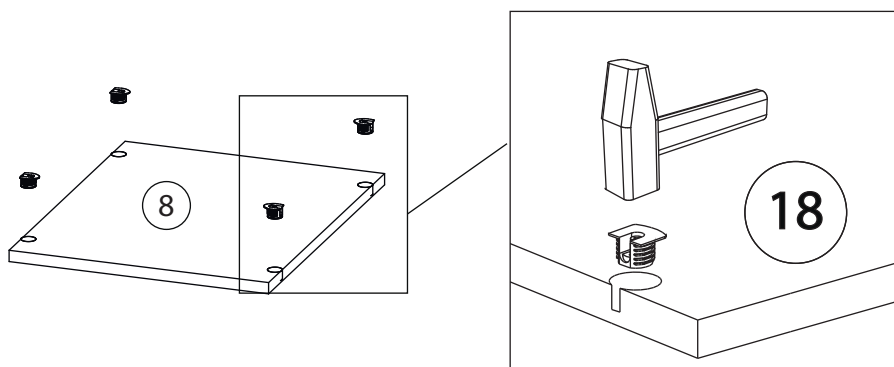

11

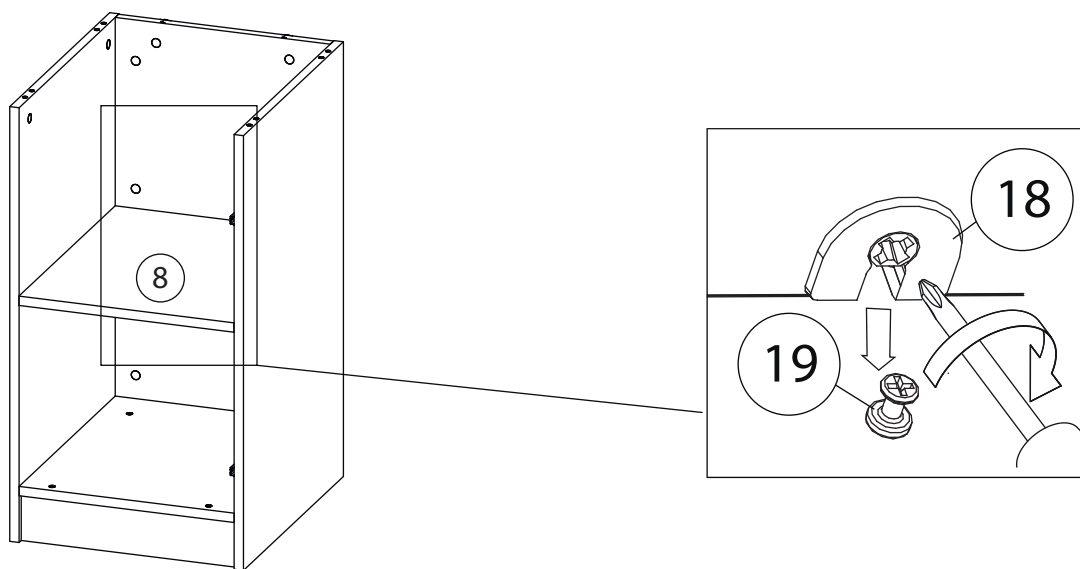

12

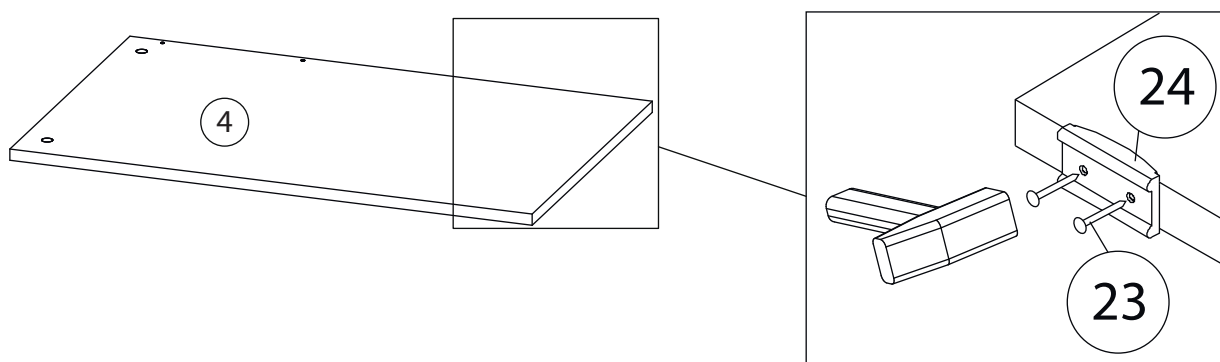

13

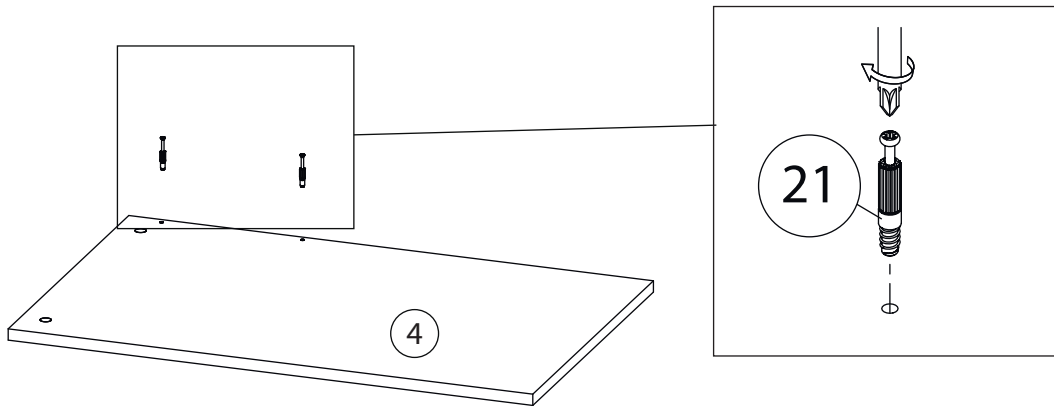

14

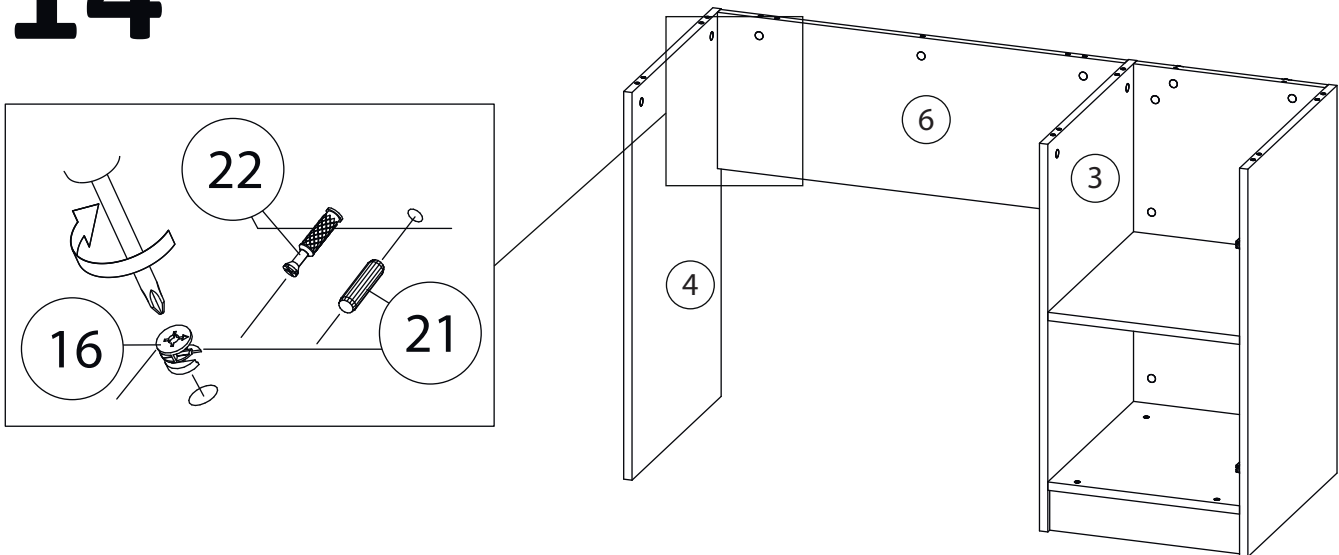

15

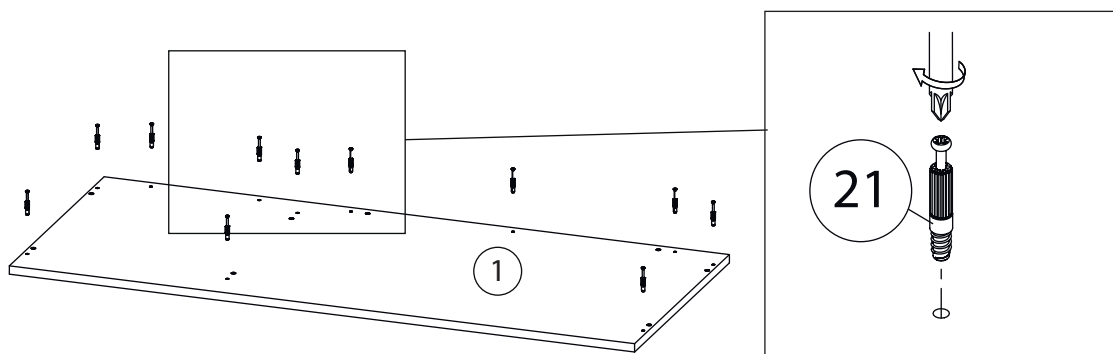

16

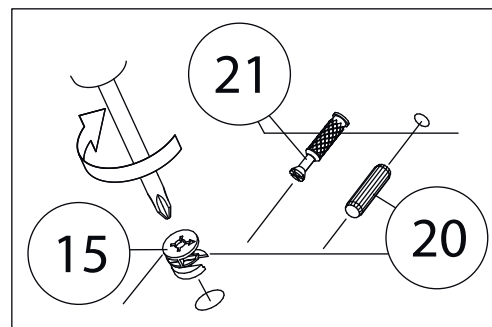
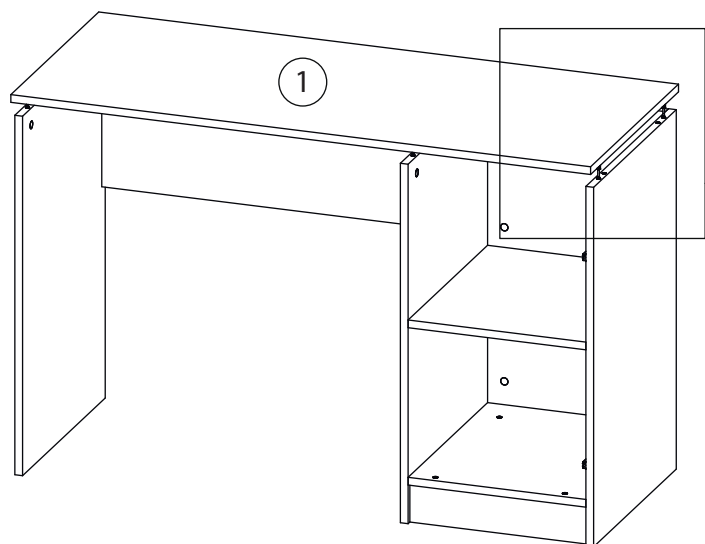

17

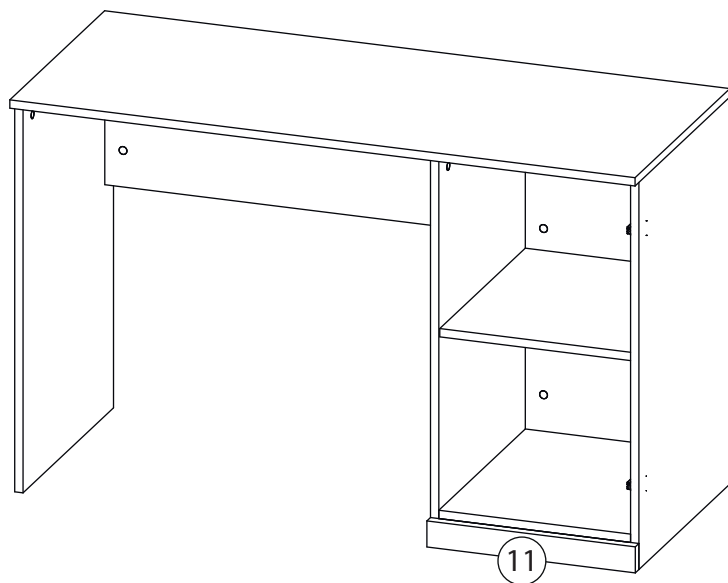

Наклеить Липкую ленту (25) на Фальш пранку (11) и прижать к Цоколю (9), согласно рисунку.

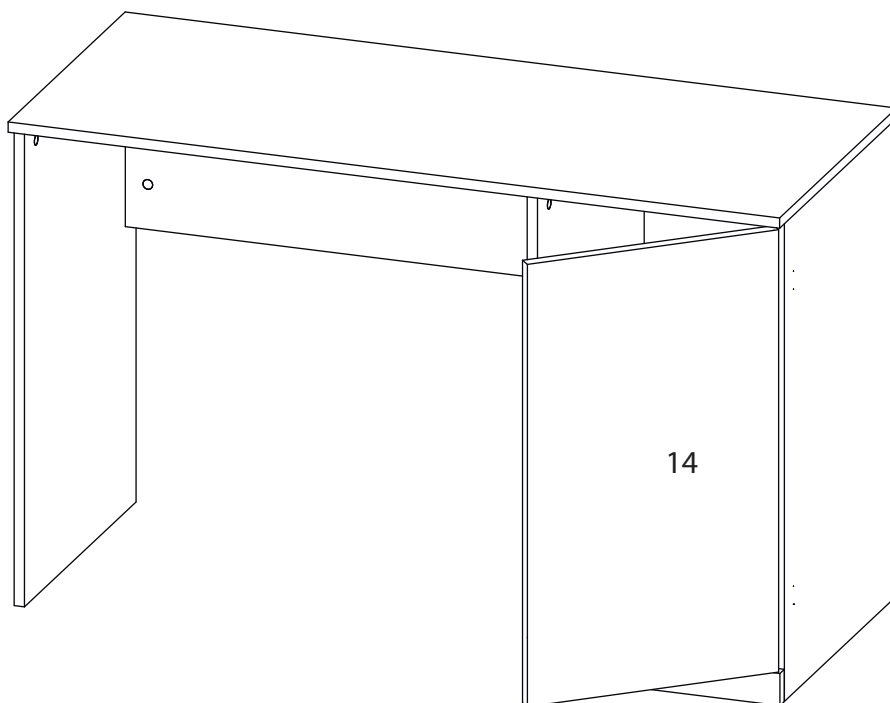
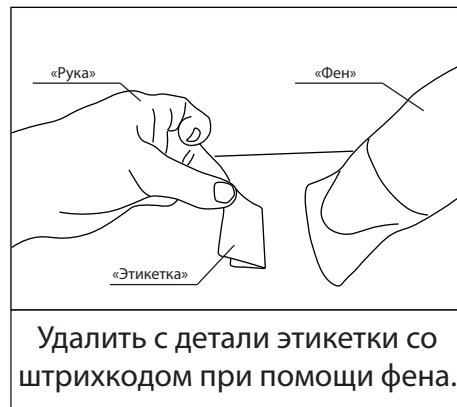

Заклеить технические отверстия заглушками.

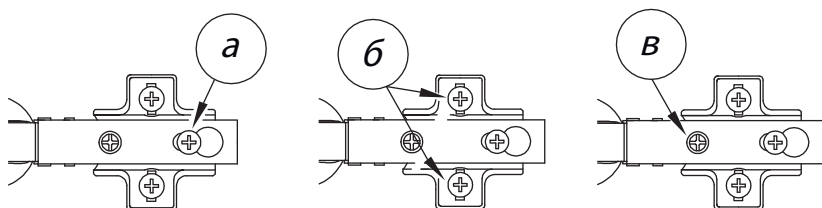

Регулировка петель

а - регулировка расстояния между дверью и корпусом
 б - регулировка положения двери по-вертикали
 в - регулировка положения ТТдвери по-горизонтали