

# Инструкция по сборке

## Банни

### Детская стенка - 12

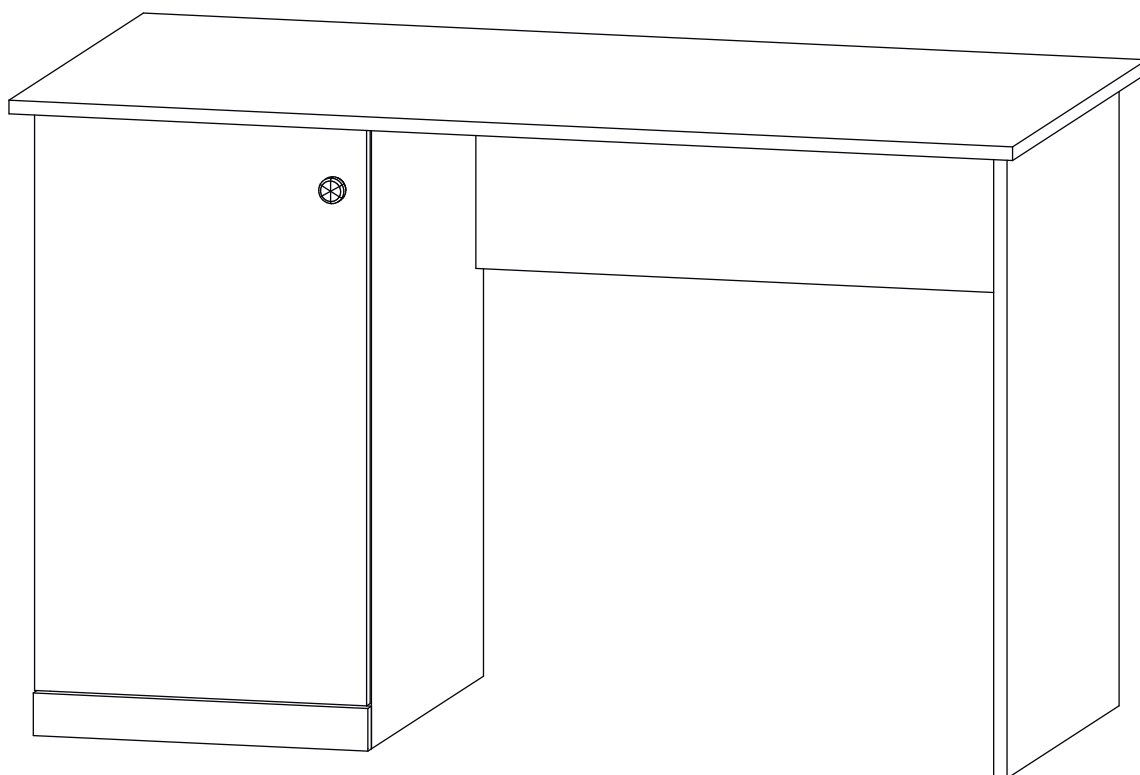

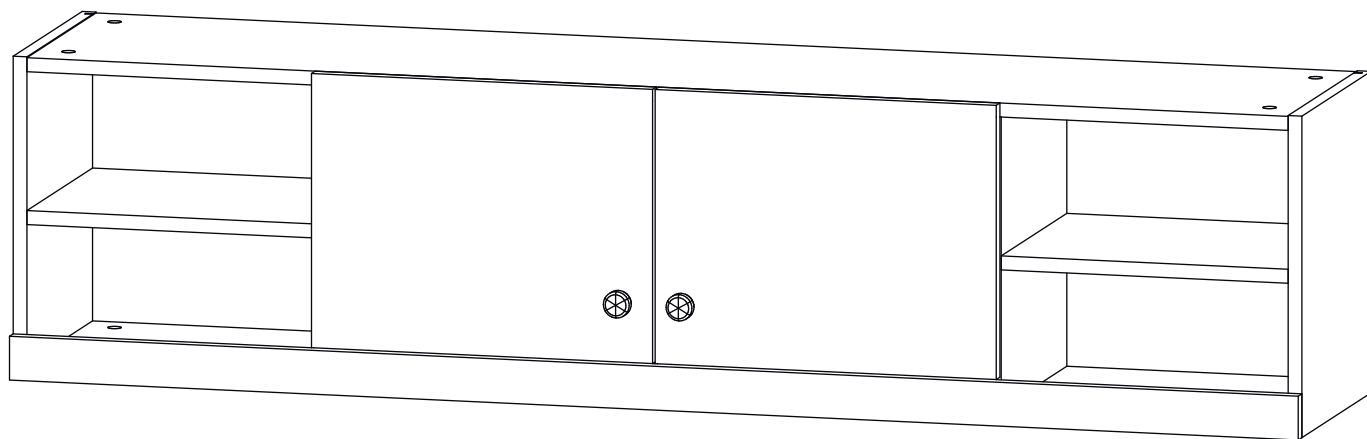

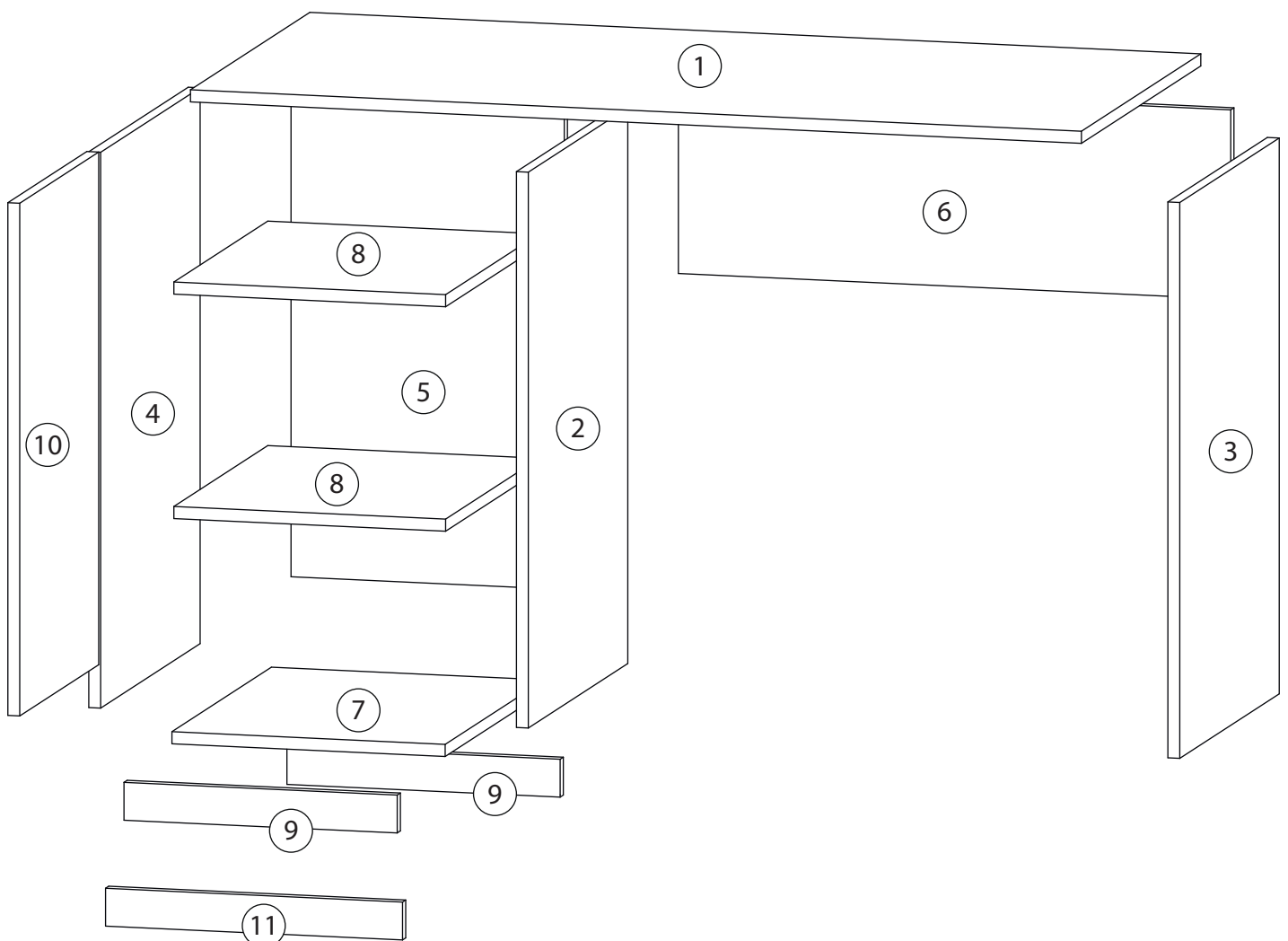

# Детали

Поз.	Наименование	Кол-во	Длина	Ширина
1	Крыша	1	1200	600
2	Вертикаль	1	734	500
3	Бок правый	1	734	500
4	Бок левый	1	734	500
5	Задняя стенка	1	668	368
6	Ребро жесткости	1	250	744
7	Дно	1	368	500
8	Полка	2	366	472
9	Цоколь	2	50	368
10	Фасад	1	677	397
11	Фальш панель	1	50	400

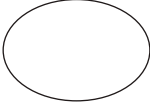
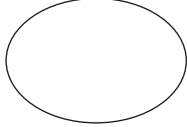
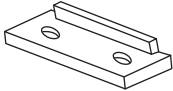
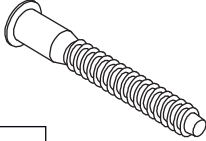
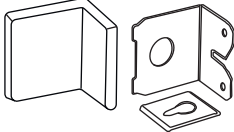

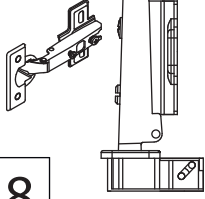
# Фурнитура

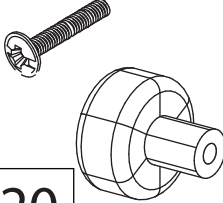
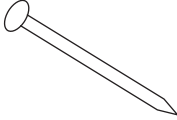
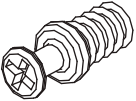
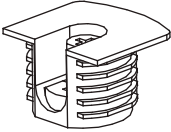
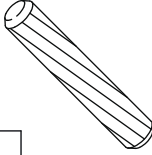
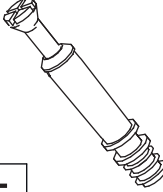
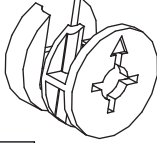
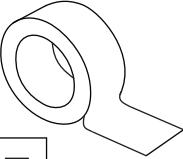
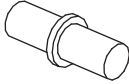
				
12	13	14	15	16
<u>Заглушка</u> Ø13	<u>Заглушка</u> Ø17-20	<u>Подпятник</u>	<u>Евровинт 7x50</u>	<u>Крепежный уголок</u>
				
17	18	19	20	21
<u>Саморез 3,5x16</u>	<u>Петля накладная</u>	<u>Евровинт 6,3x13</u>	<u>Ручка</u> <u>кнопка</u>	<u>Гвоздь 1,6x25</u>
				
22	23	24	25	26
<u>Винт для стяжки</u> <u>VB35</u>	<u>Стяжка VB35</u>	<u>Шкант бук</u>	<u>Шток эксцентрика</u>	<u>Эксцентрик</u>
				
27	28			
<u>2-х сторонний</u> <u>скотч</u>	<u>Полкодержатель</u>			

# 1

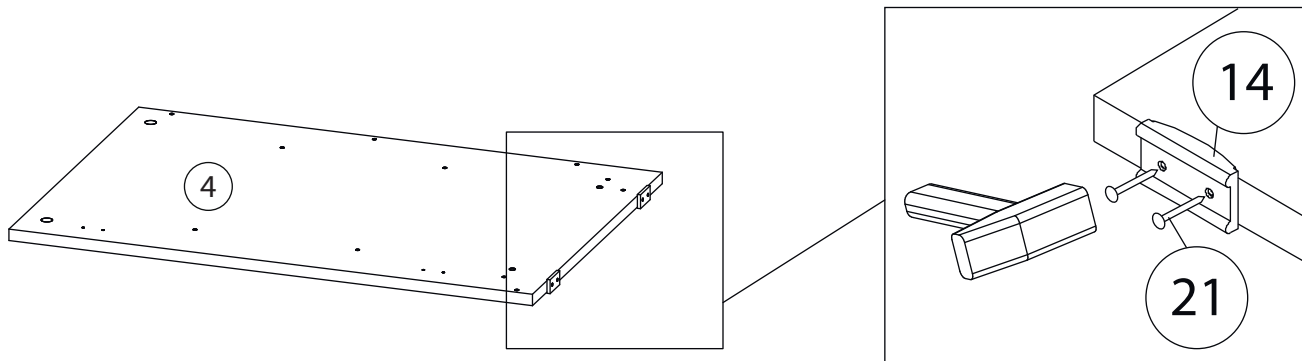

# 2

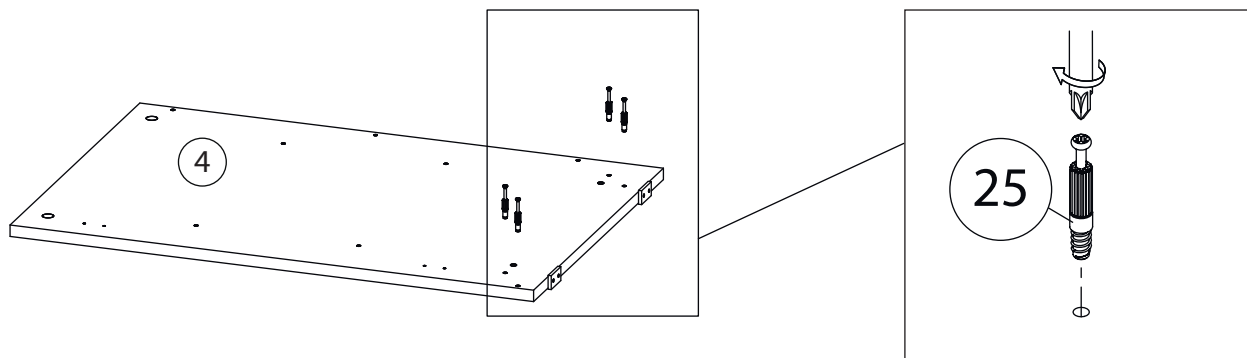

# 3

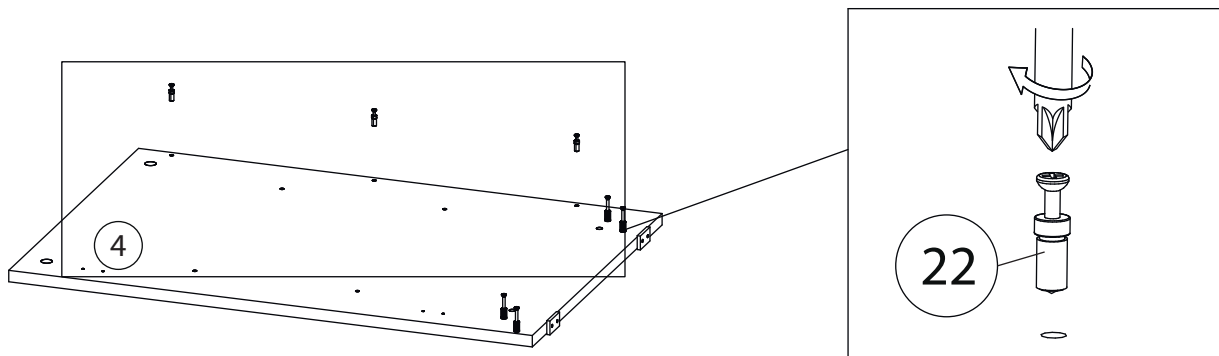

Вертикаль ( 2 )  
собирается зеркально

# 4

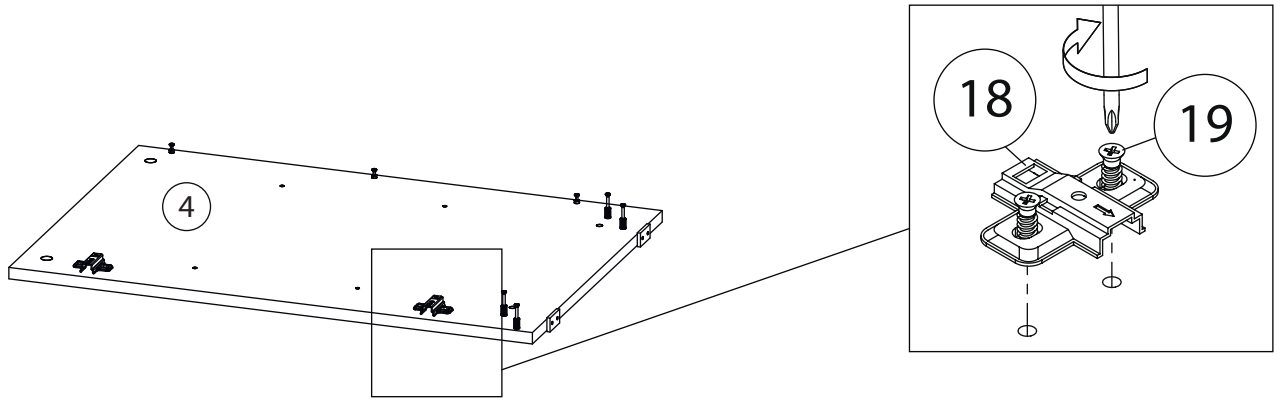

# 5

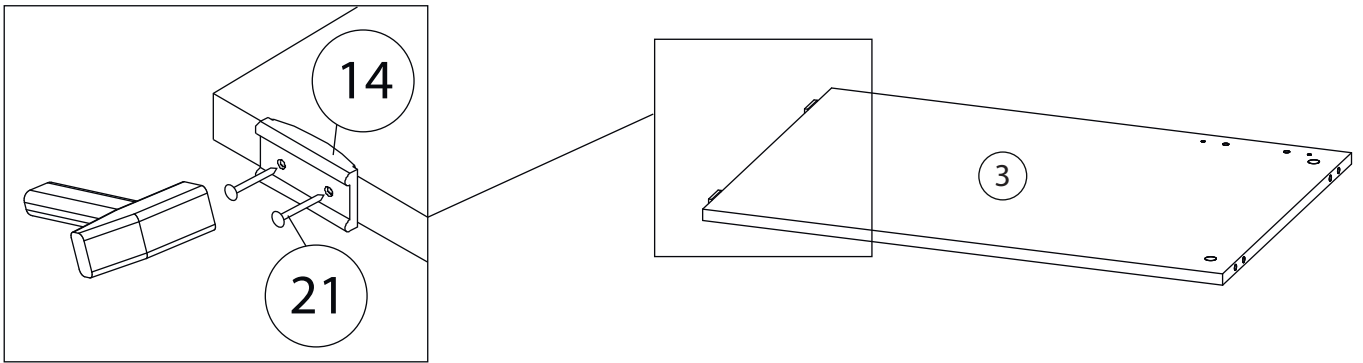

# 6

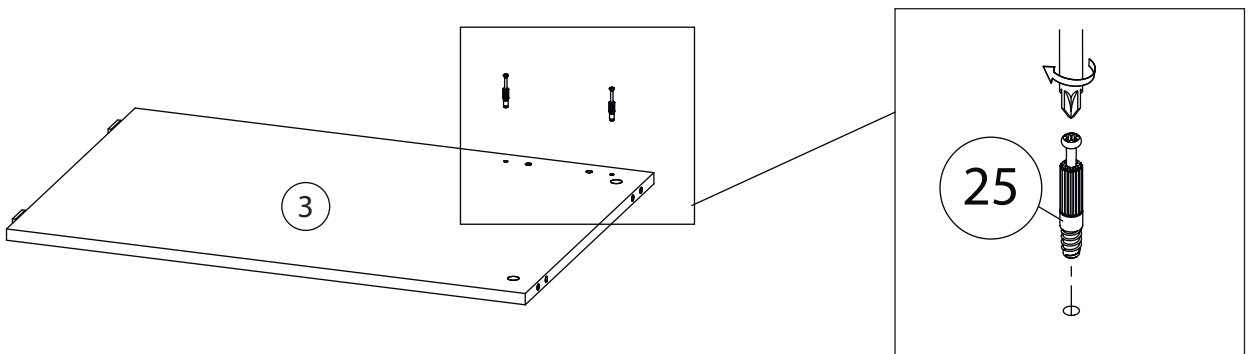

# 7

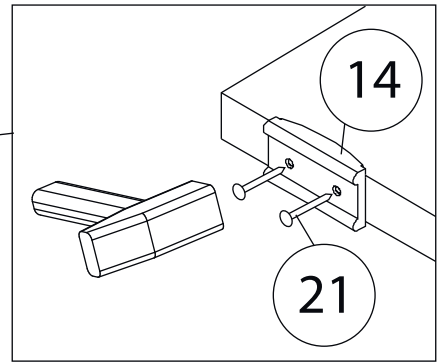
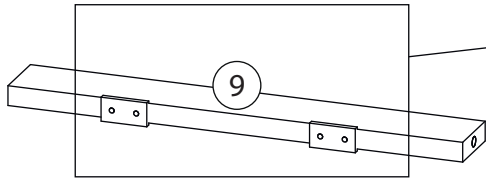

Второй цоколь (9)  
собирается аналогично

# 8

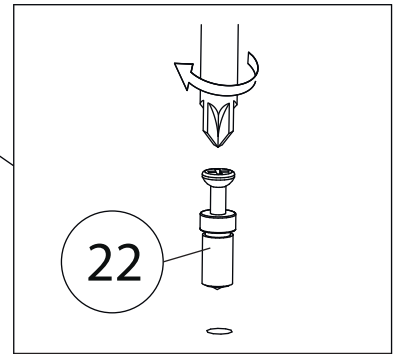
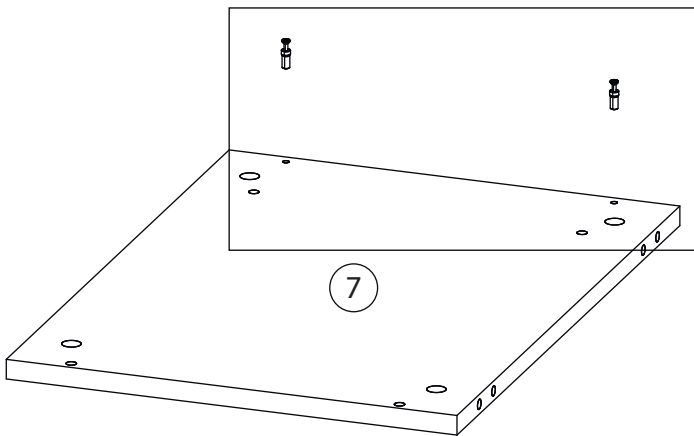

# 9

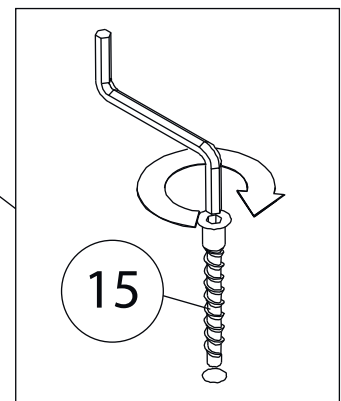
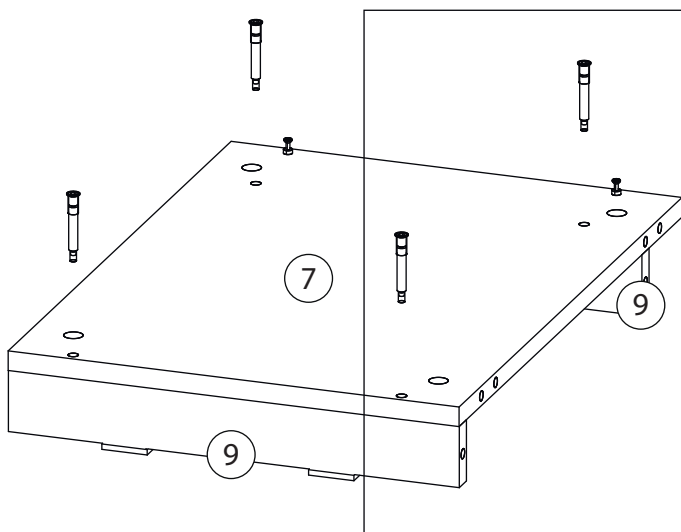

# 10

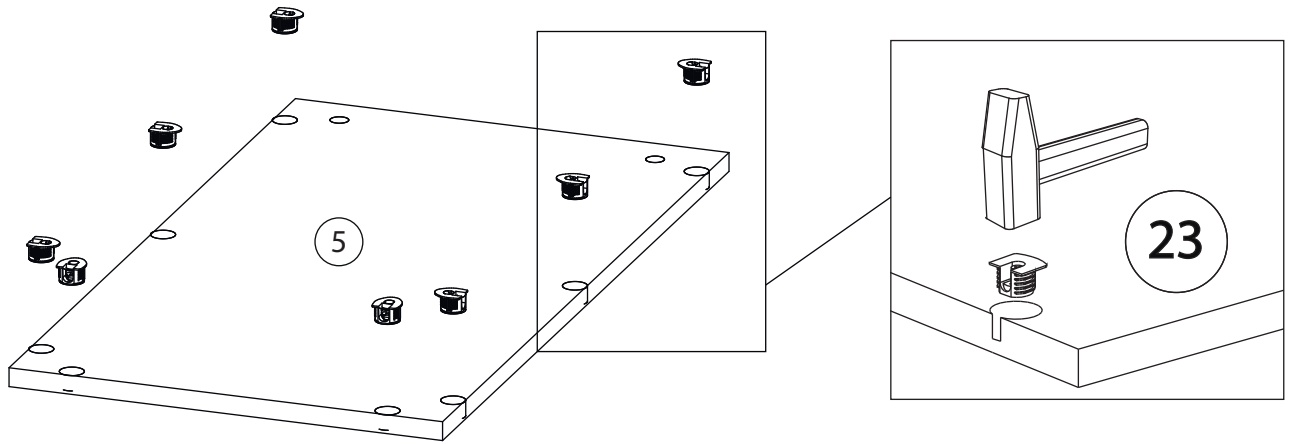

# 11

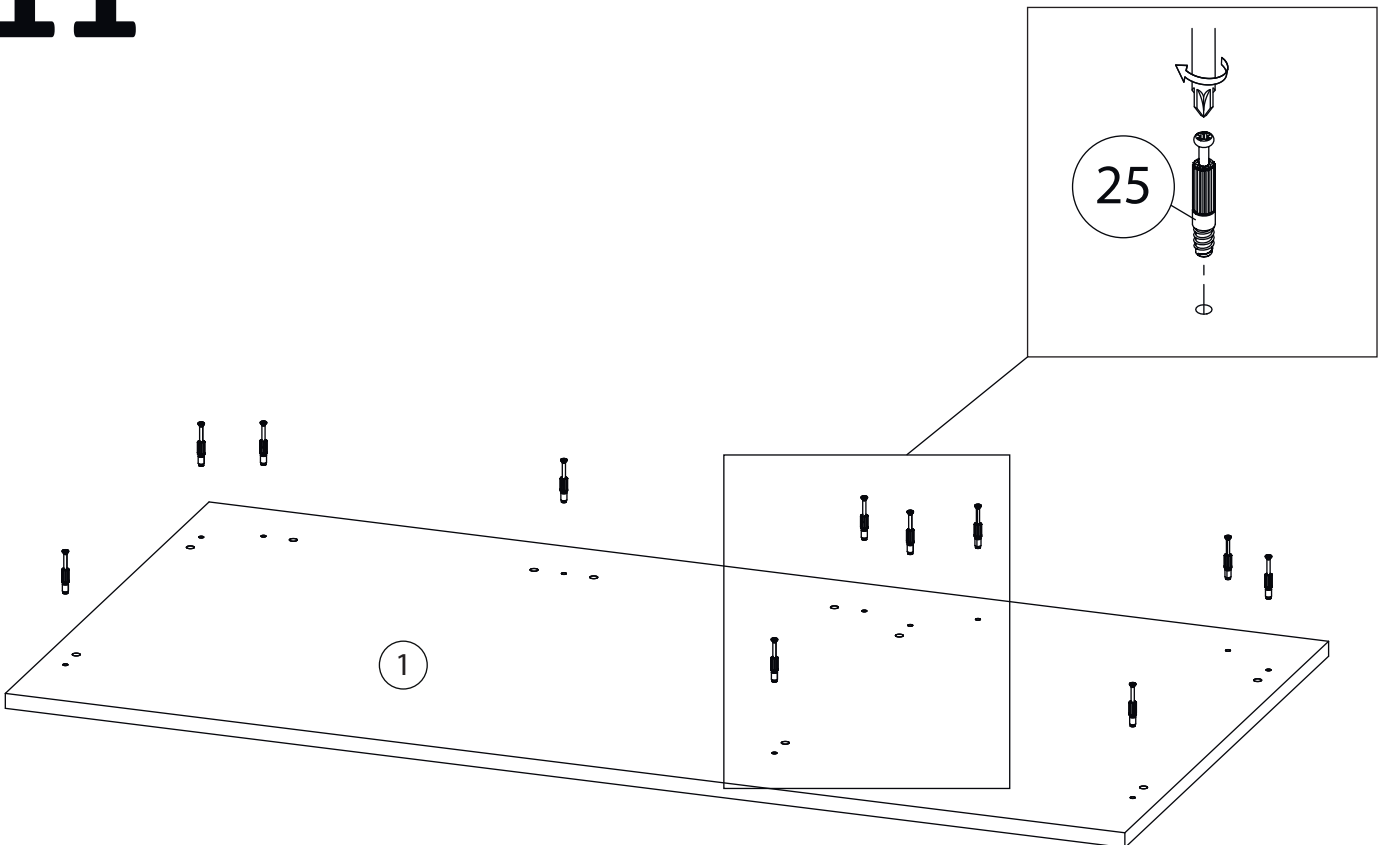

# 12

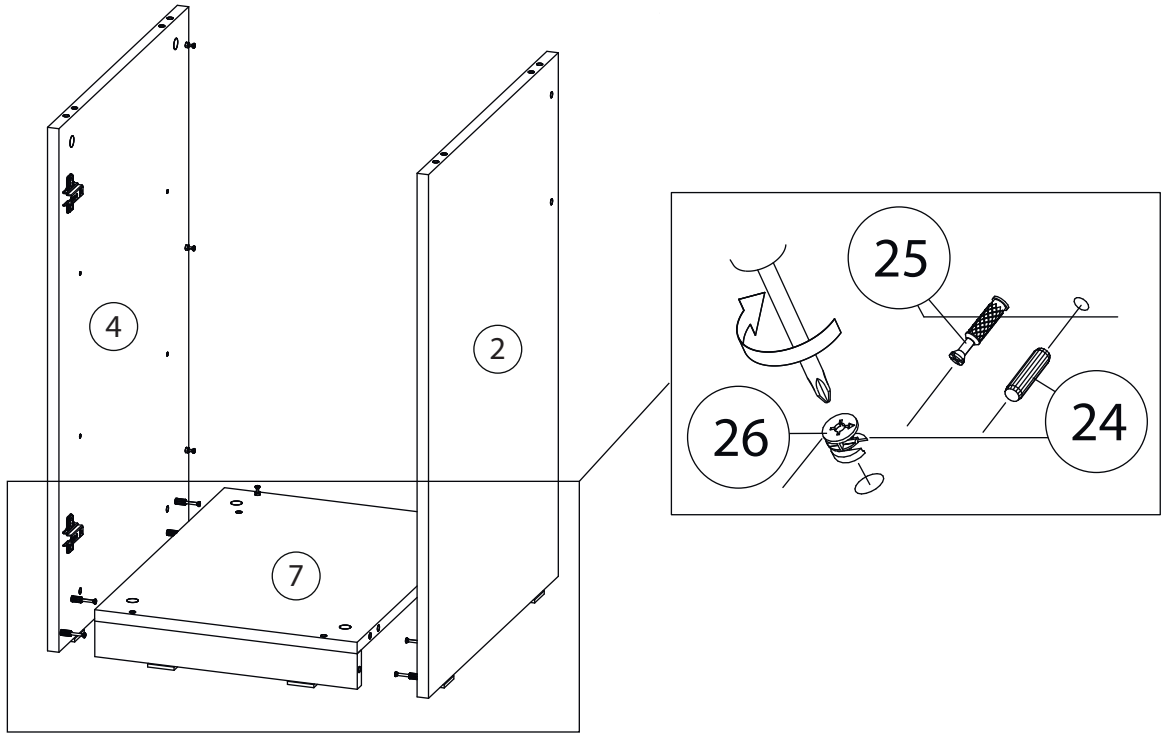

# 13

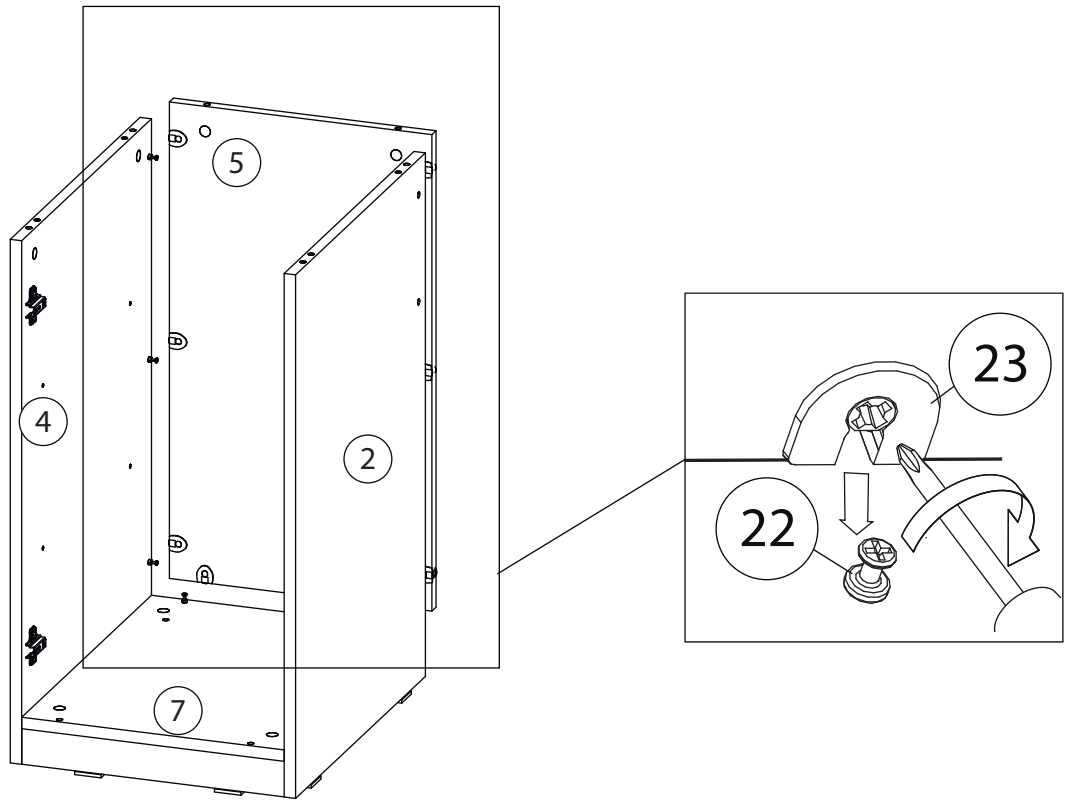

# 14

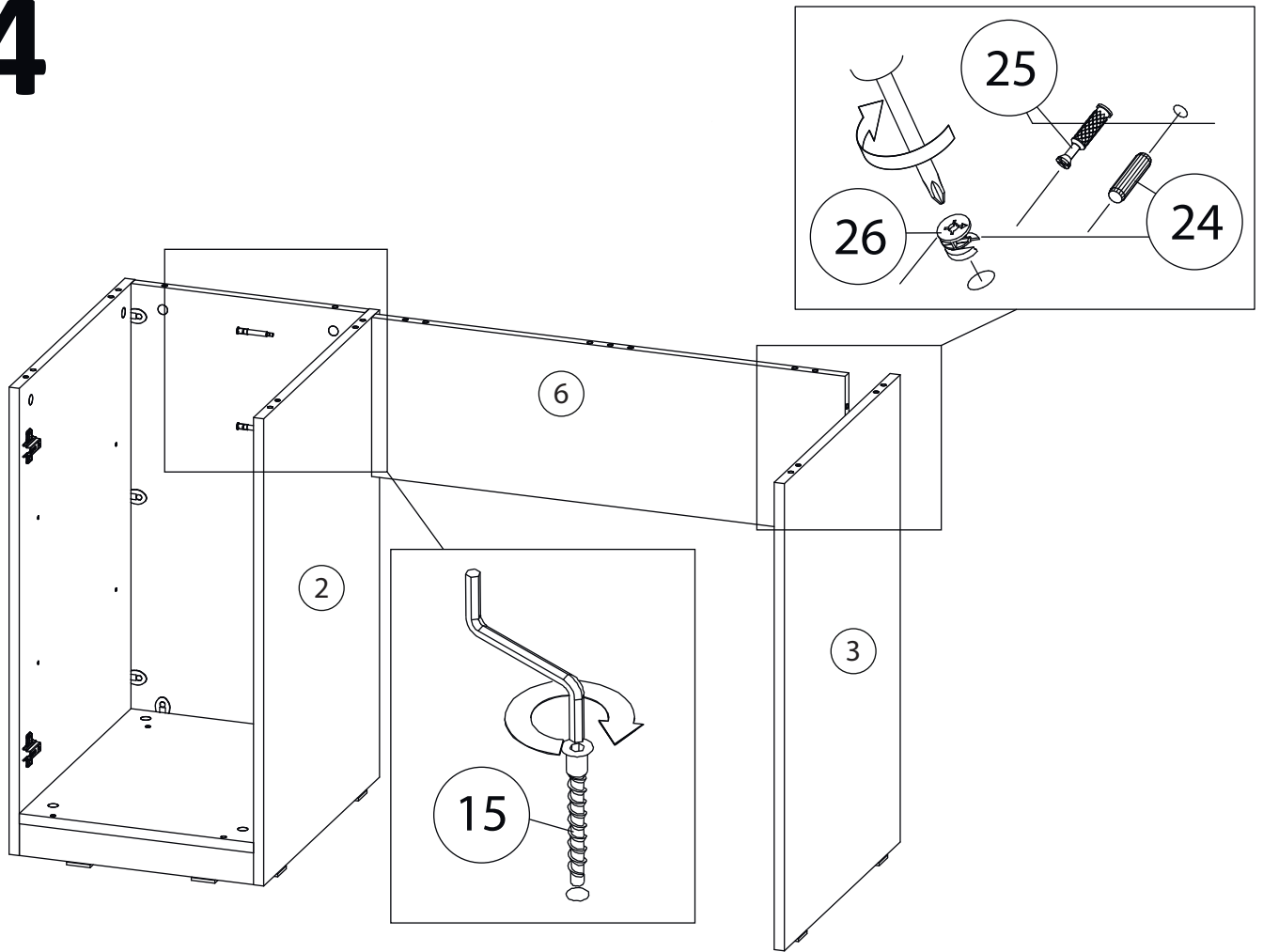

# 15

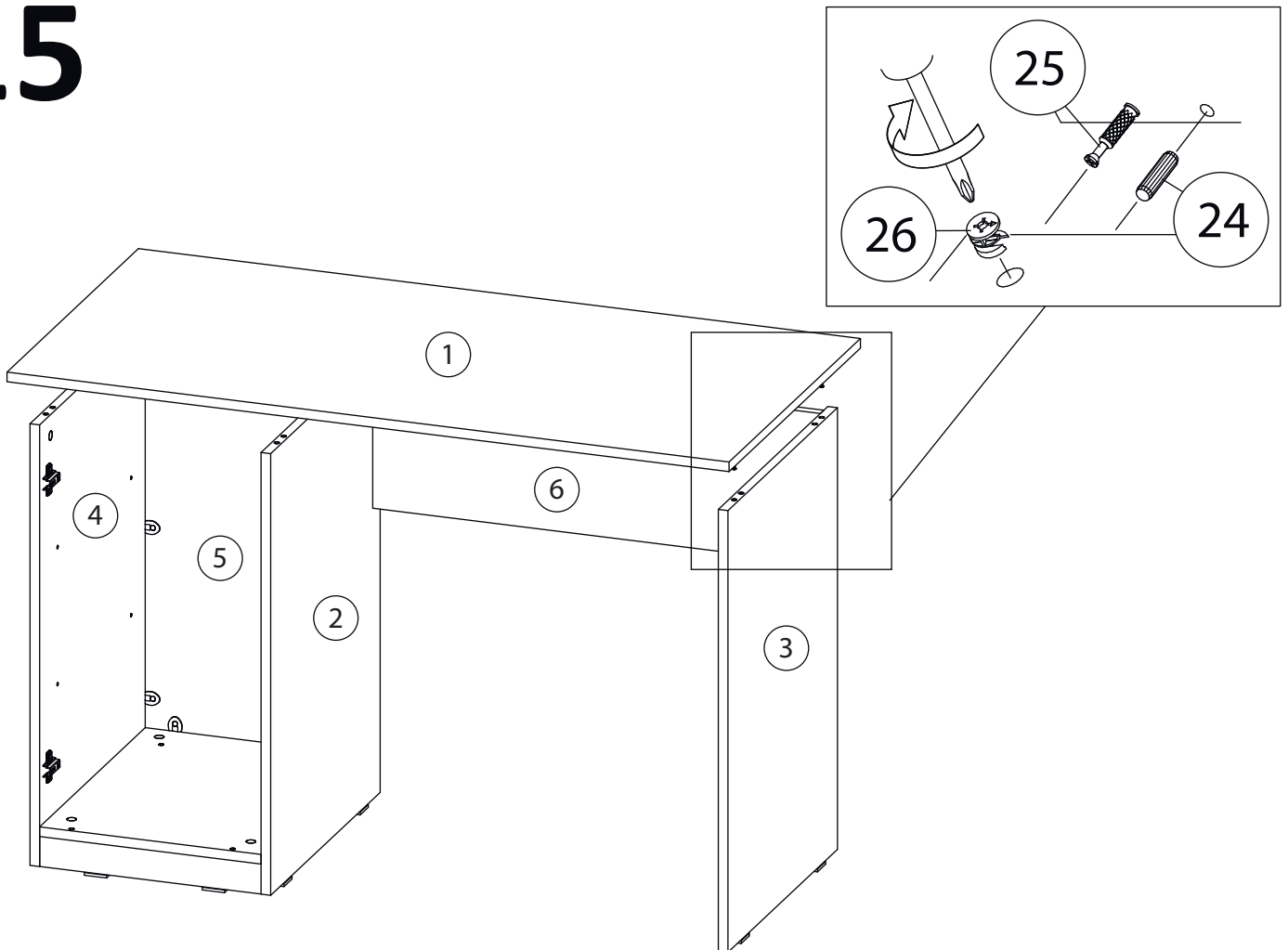

# 16

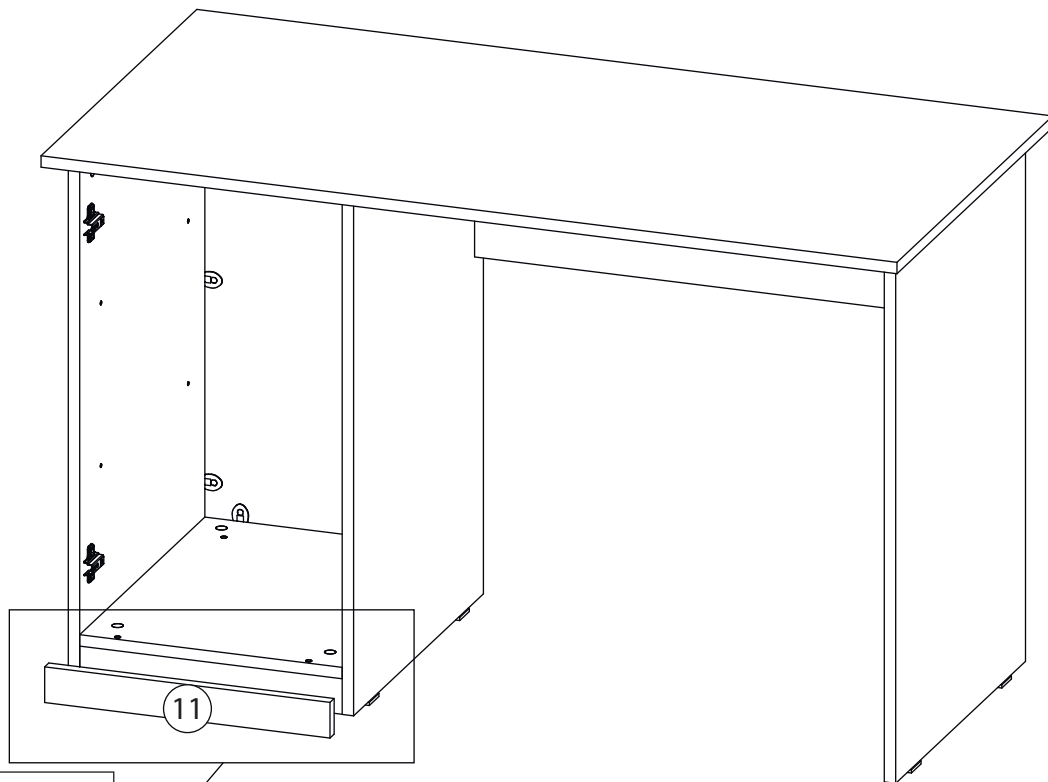

Наклеить липкую ленту (27) на фальш панель (11) и прижать к цоколю (9) согласно рисунка

# 17

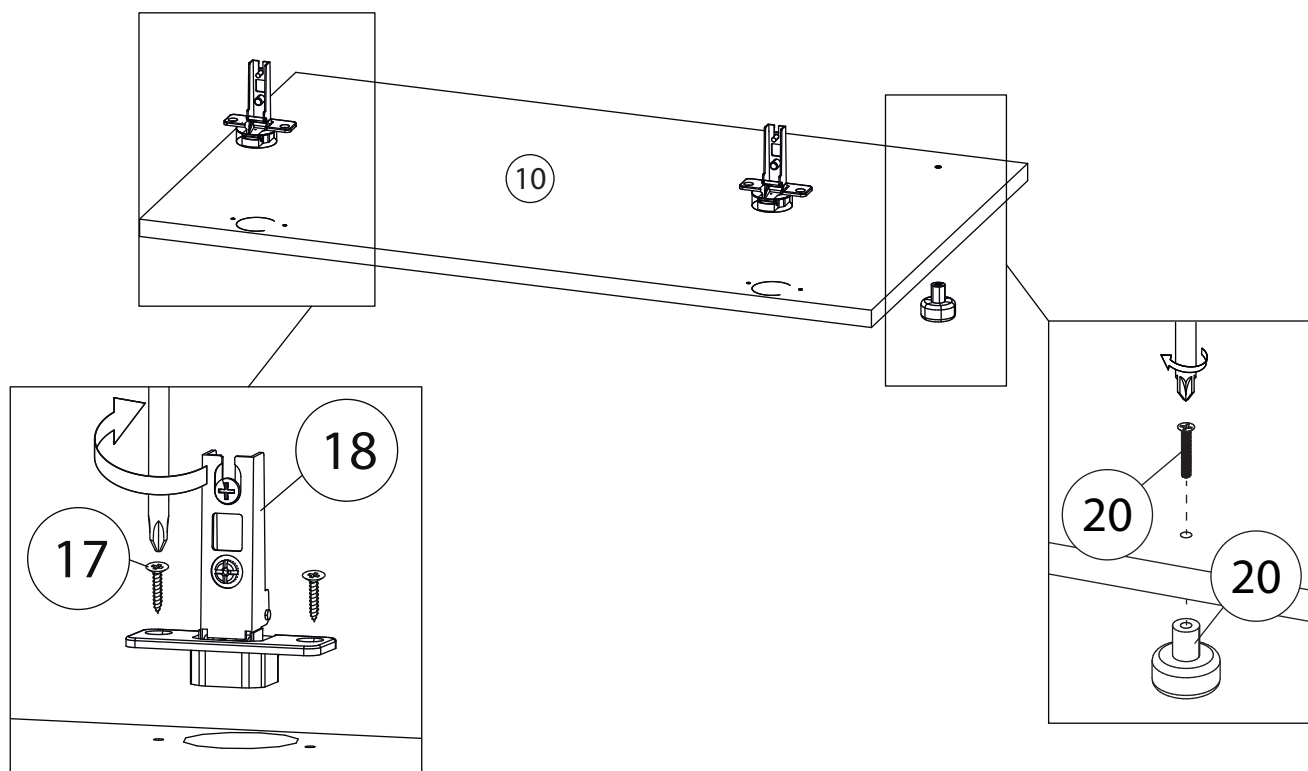

# 18

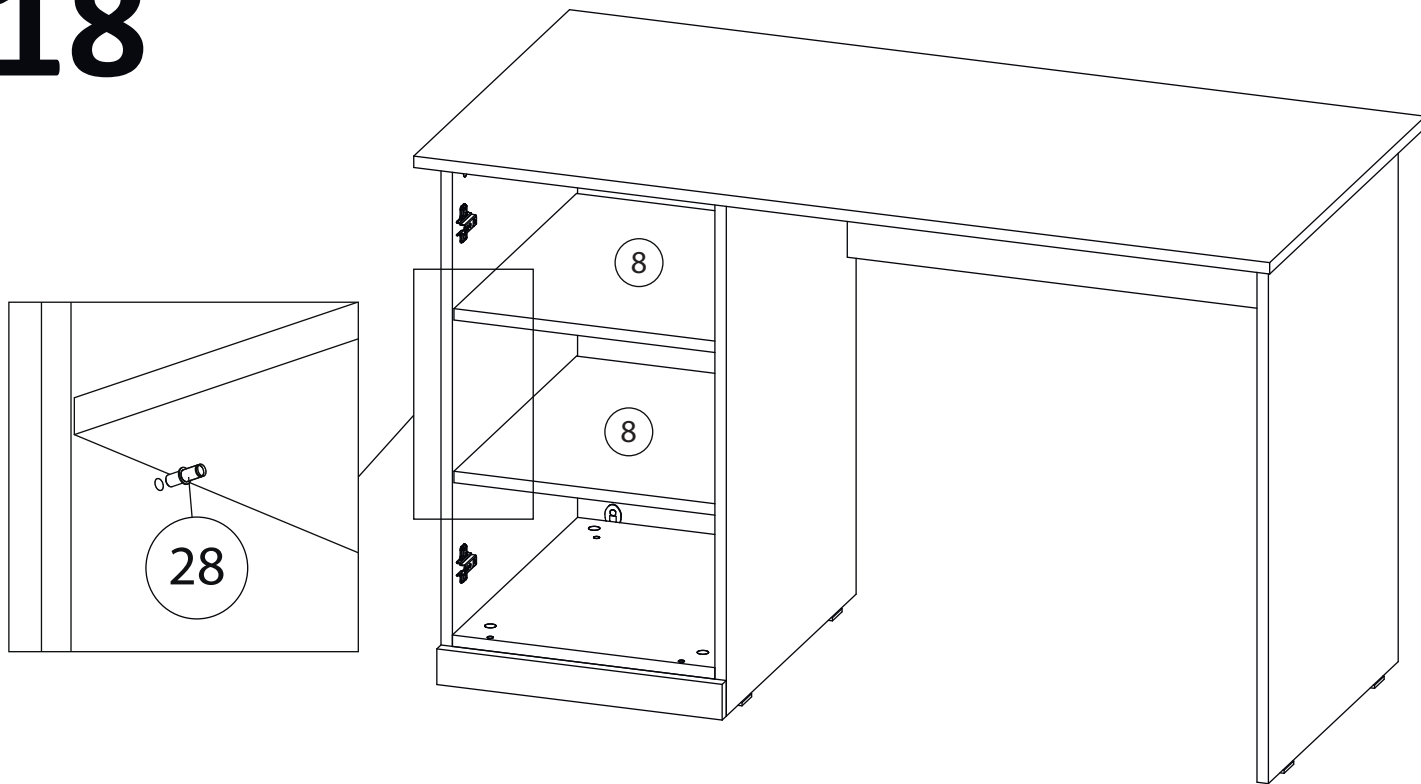

# 19

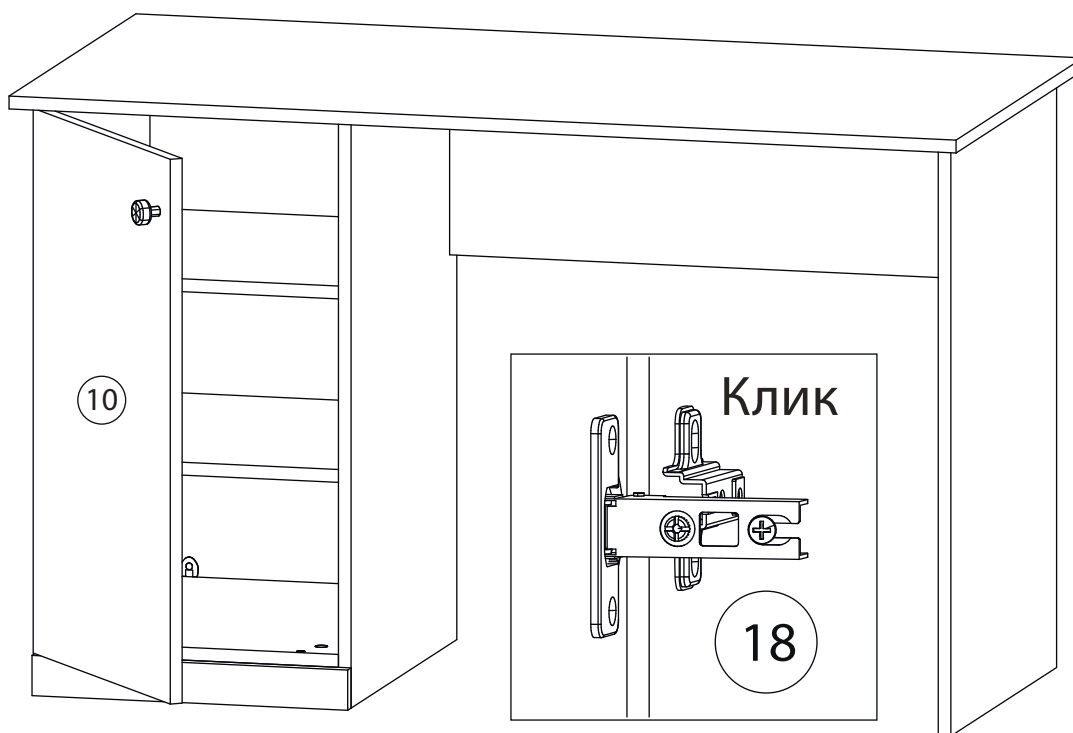

Заклеить технические отверстия заглушками.

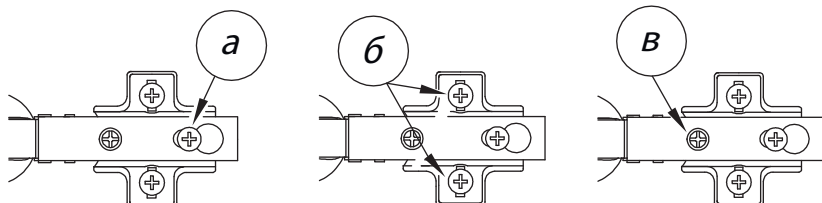

### Регулировка петель

а - регулировка расстояния между дверью и корпусом  
б - регулировка положения двери по-вертикали  
в - регулировка положения двери по-горизонтали

# Детали

Поз.	Наименование	Кол-во	Длина	Ширина
1	Крыша	1	1468	300
2	Дно	1	1468	300
3	Бок левый	1	367	300
4	Бок правый	1	367	300
5	Полка	2	334	285
6	Вертикальная 3	1	333	285
7	Вертикальная 2	1	333	285
8	Вертикальная 1	1	333	285
9	Вертикальная 4	1	333	285
10	Фасад правый	1	313	397
11	Фасад левый	1	313 <td 397	
12	Планка	1	50	1500
13	Задняя стенка	1	349	742
14	Задняя стенка	1	349	742

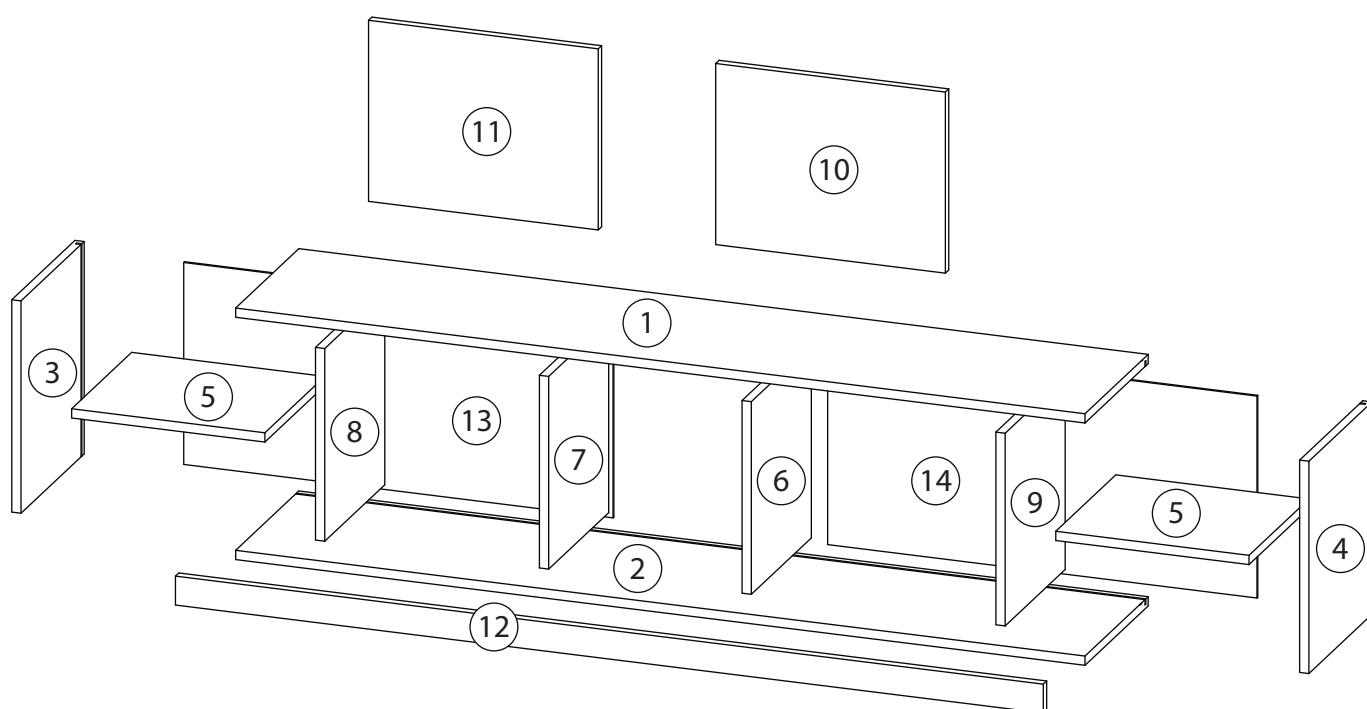

# Фурнитура

 <p>15</p>	 <p>16</p>	 <p>17</p>	 <p>18</p>	 <p>19</p>
<p><u>Шток эксцентрика</u></p>	<p><u>Эксцентрик</u></p>	<p><u>Шкант бук</u></p>	<p><u>Саморез 3,5x16</u></p>	<p><u>Ручка кнопка</u></p>
 <p>20</p>	 <p>21</p>	 <p>22</p>	 <p>23</p>	 <p>24</p>
<p><u>Подвес + заглушка</u></p>	<p><u>Полоса крепёжная</u></p>	<p><u>Фиксатор задней стенки</u></p>	<p><u>Петля накладная</u></p>	<p><u>Заглушка Ø17-20</u></p>
 <p>25</p>	 <p>26</p>	 <p>27</p>		
<p><u>Евровинт 6,3x13</u></p>	<p><u>Винт для стяжки VB35</u></p>	<p><u>Стяжка VB35</u></p>		

# 1

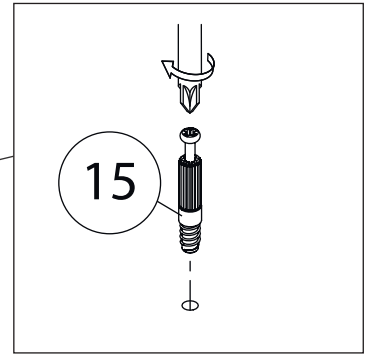
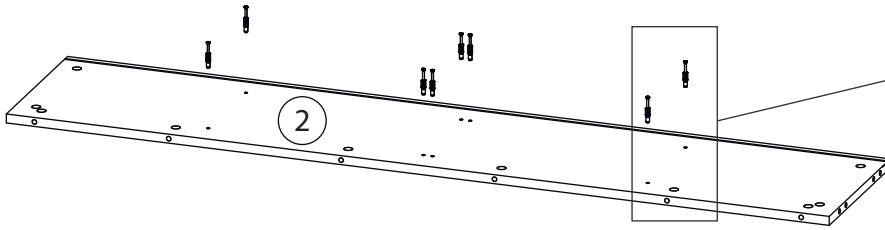

# 2

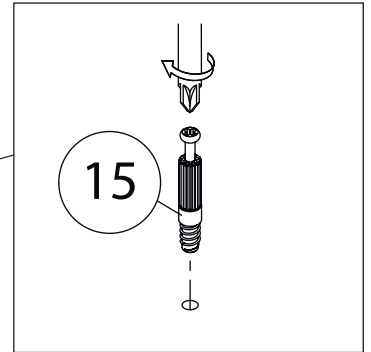
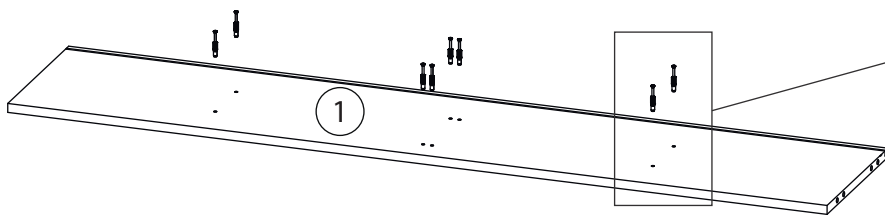

# 3

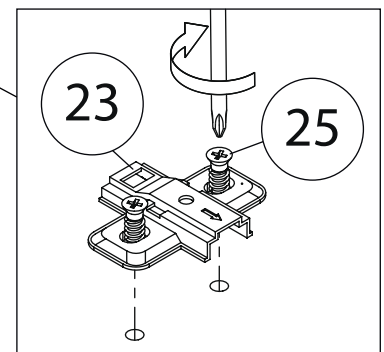
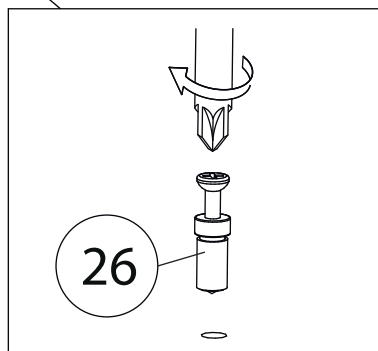
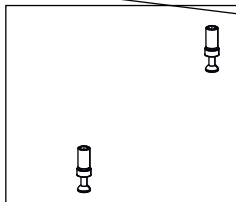
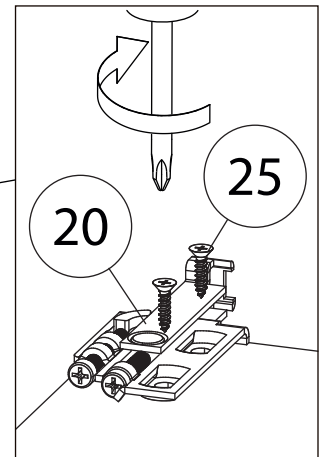
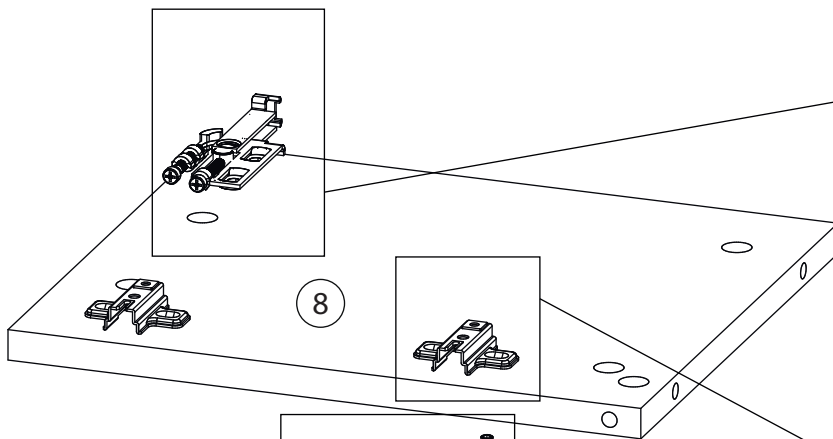

# 4

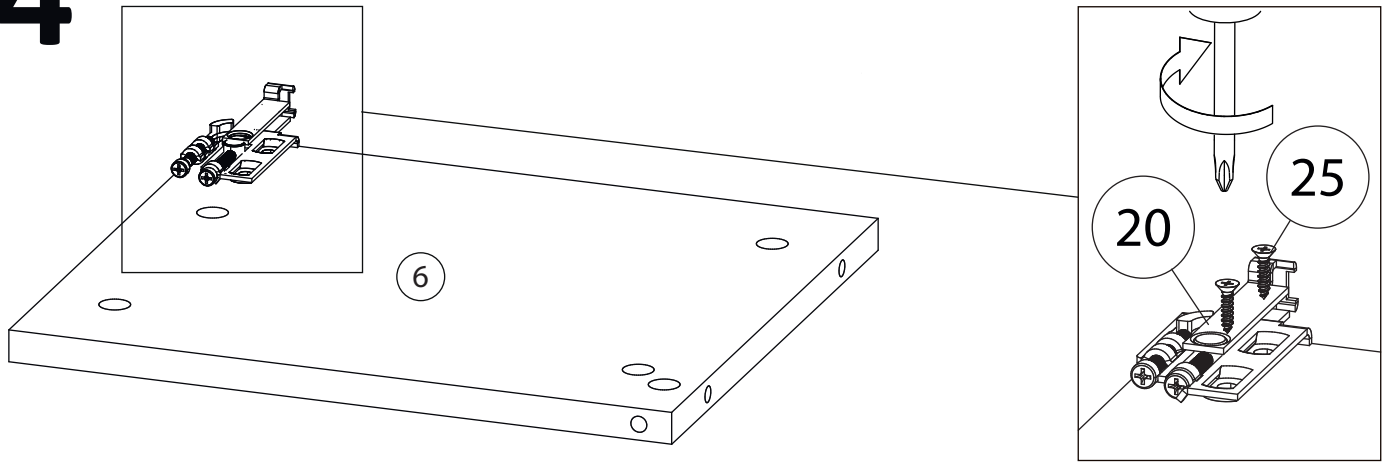

# 5

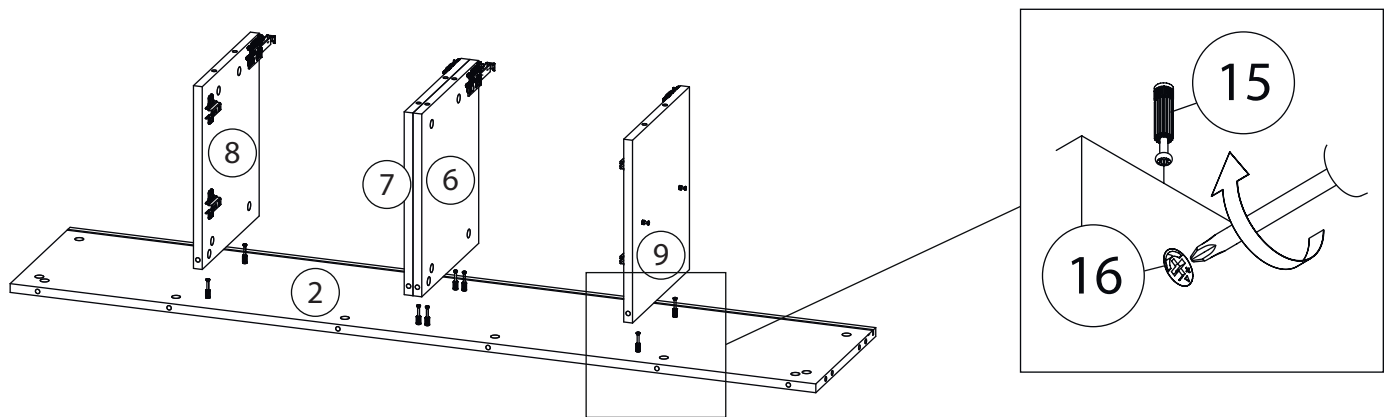

# 6

Вырежьте прорези для навесов согласно приложенной схеме.

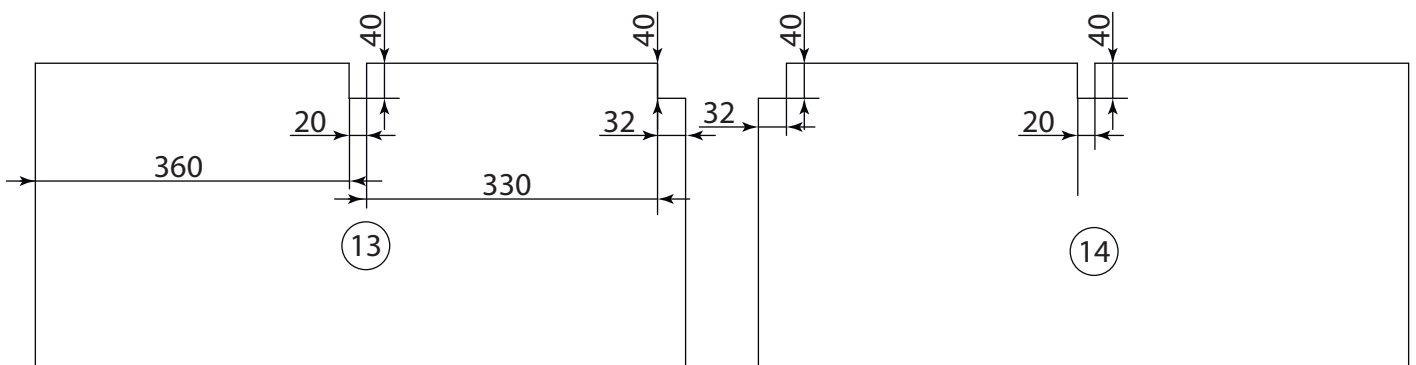

# 7

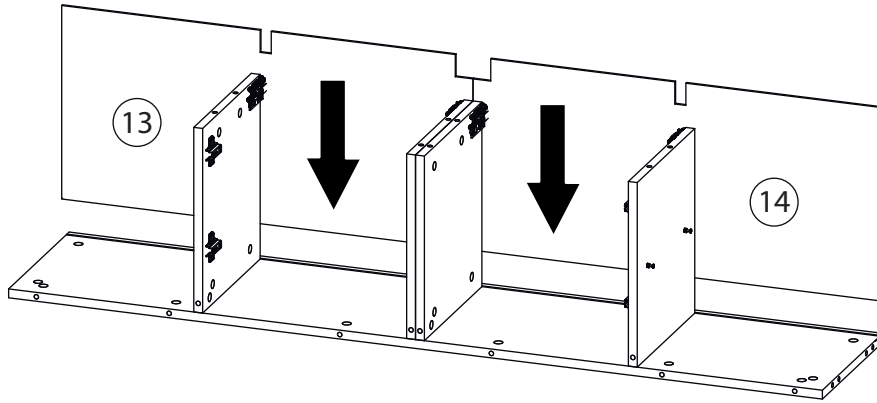

# 8

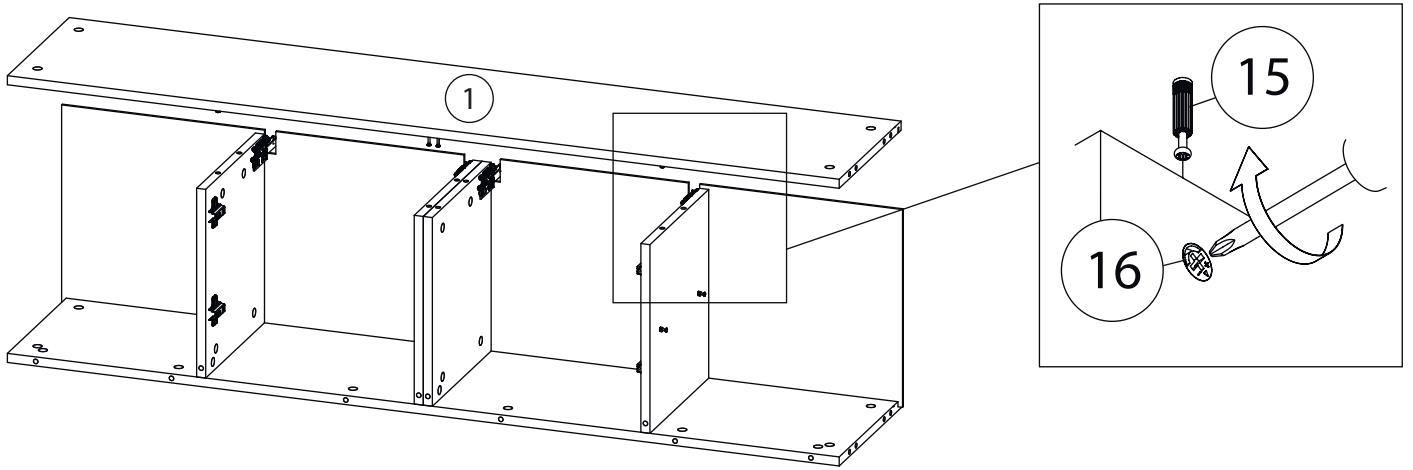

# 9

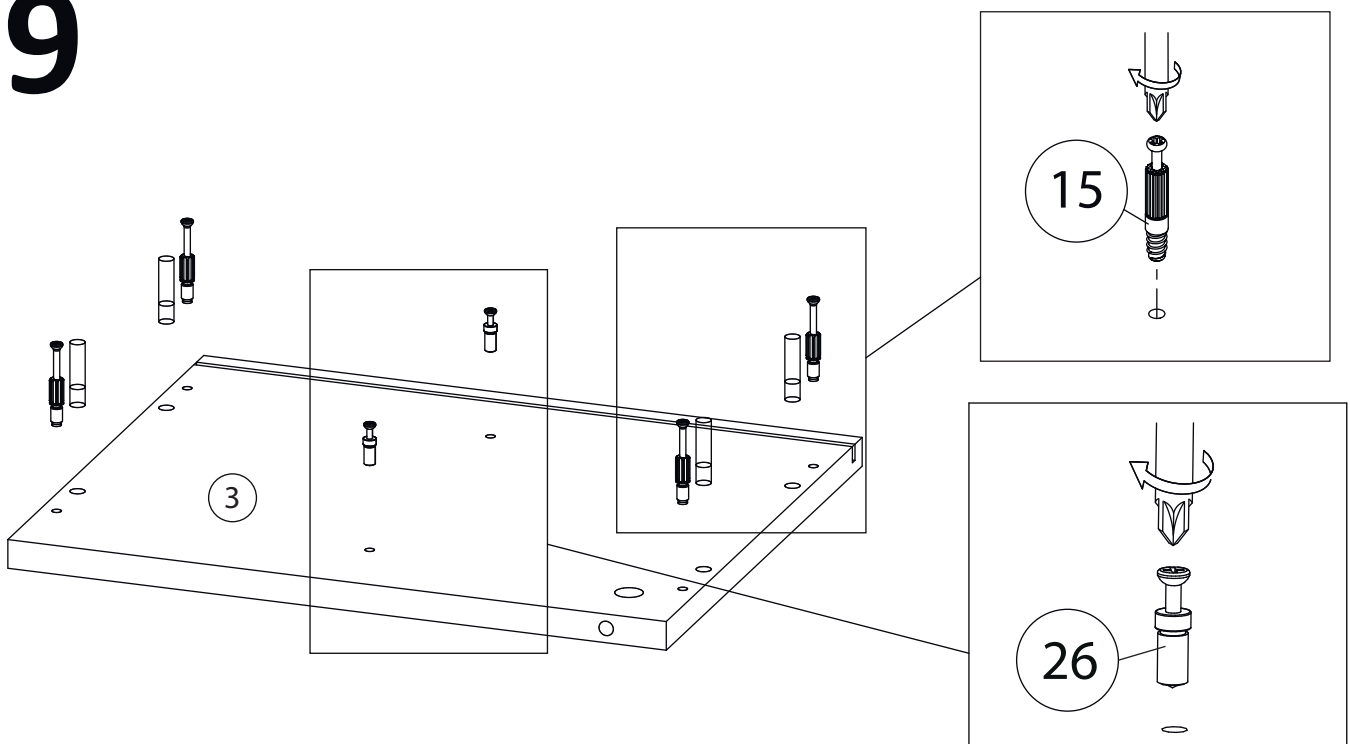

# 10

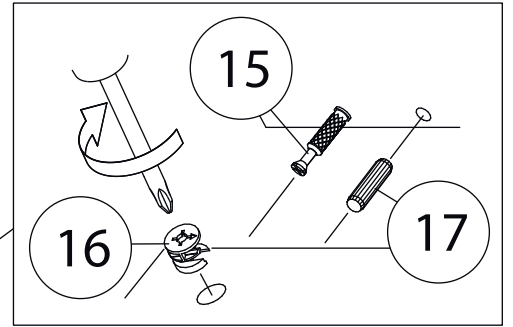
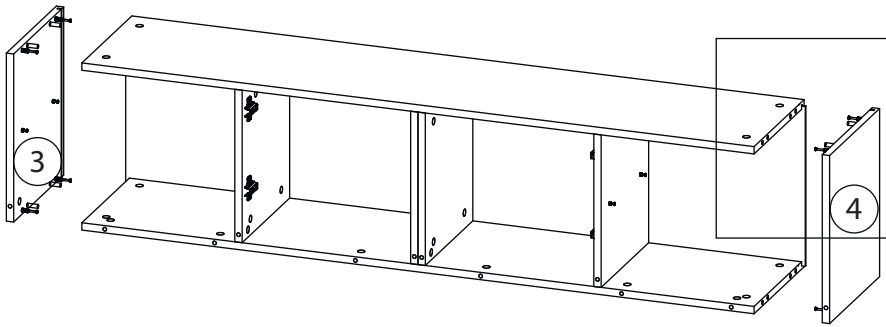

# 11

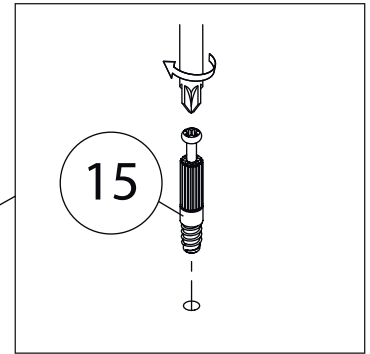
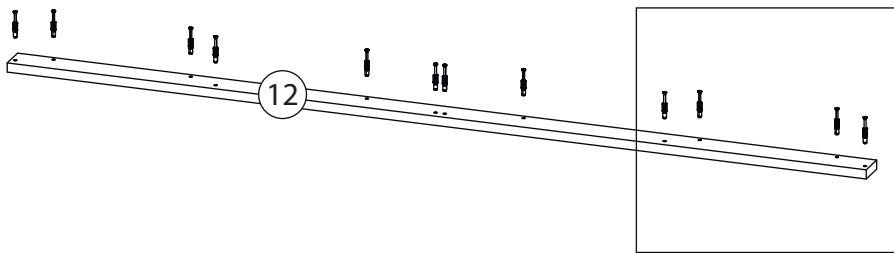

# 12

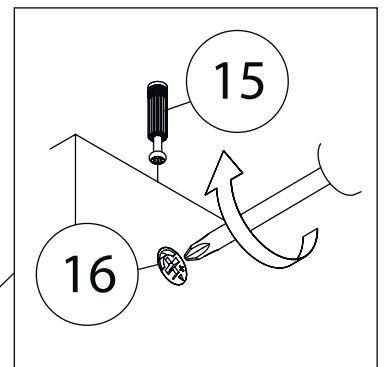
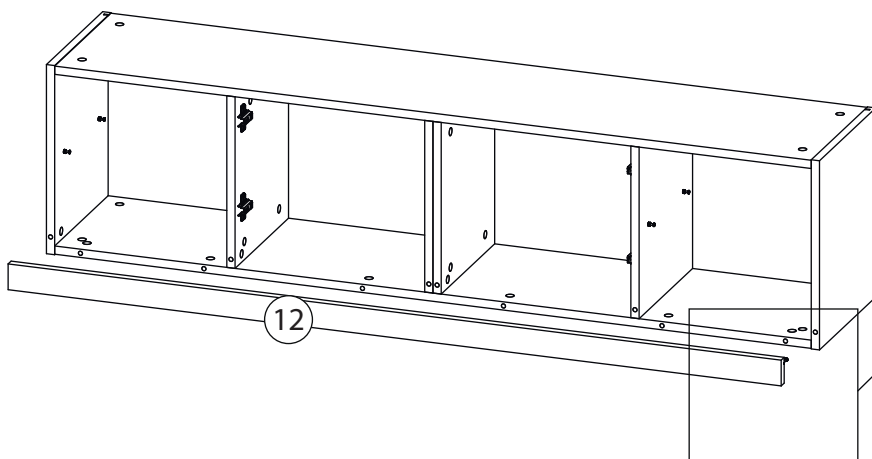

# 13

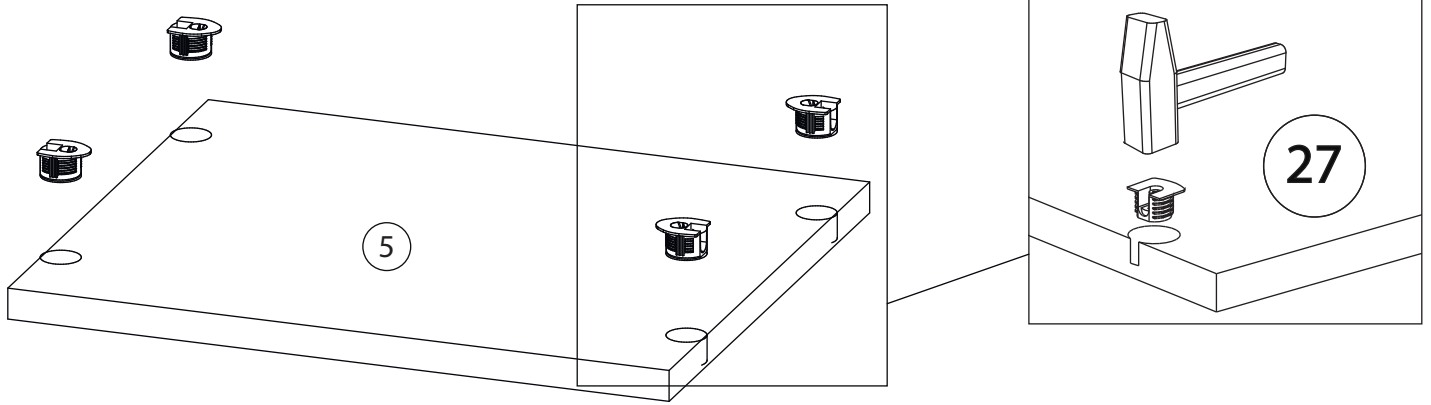

# 14

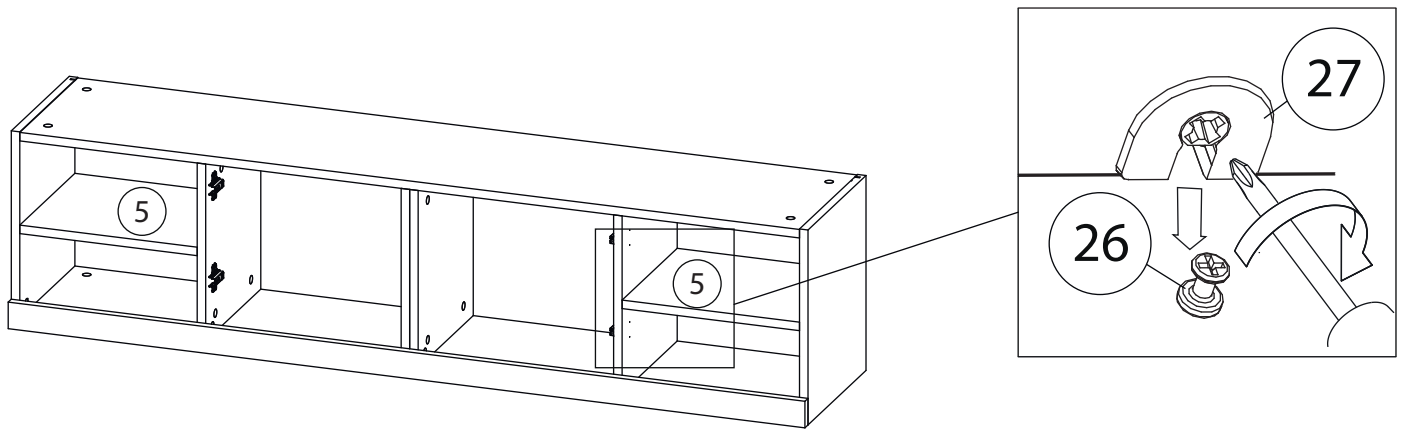

# 15

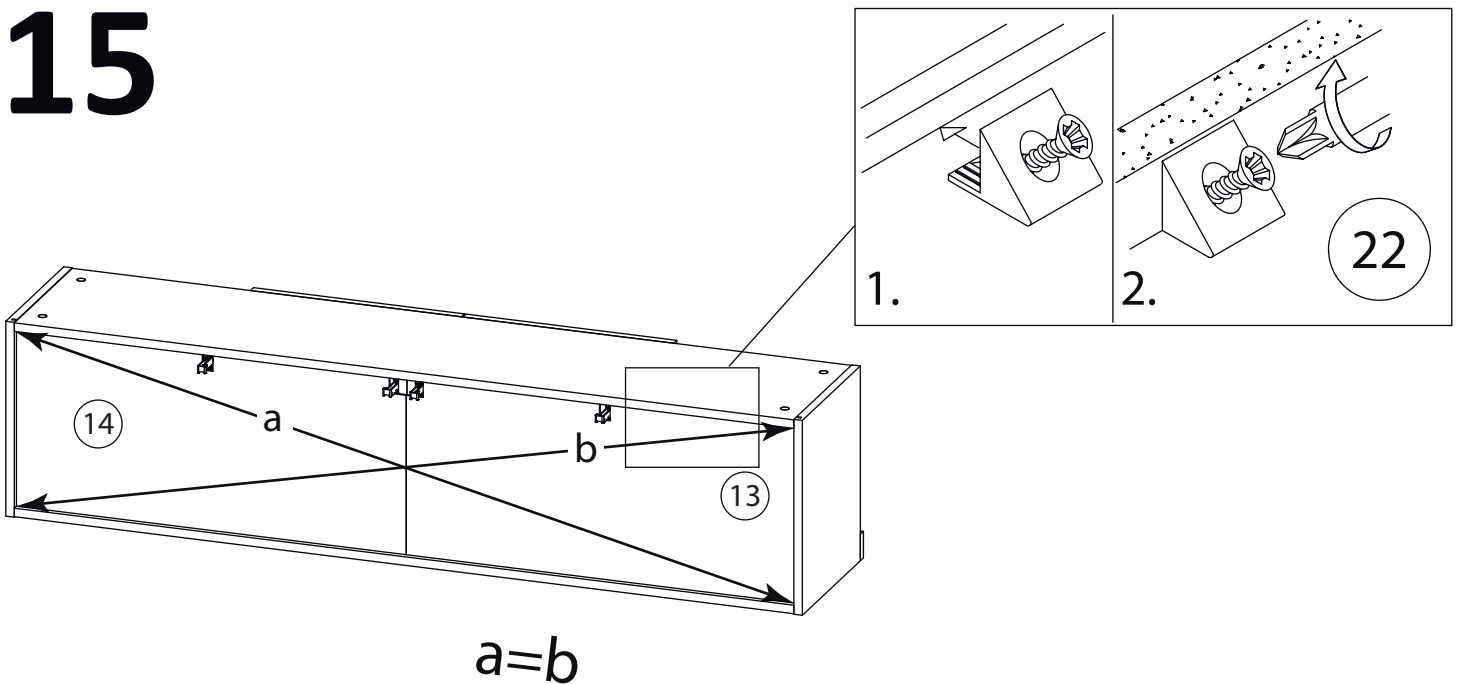

# 16

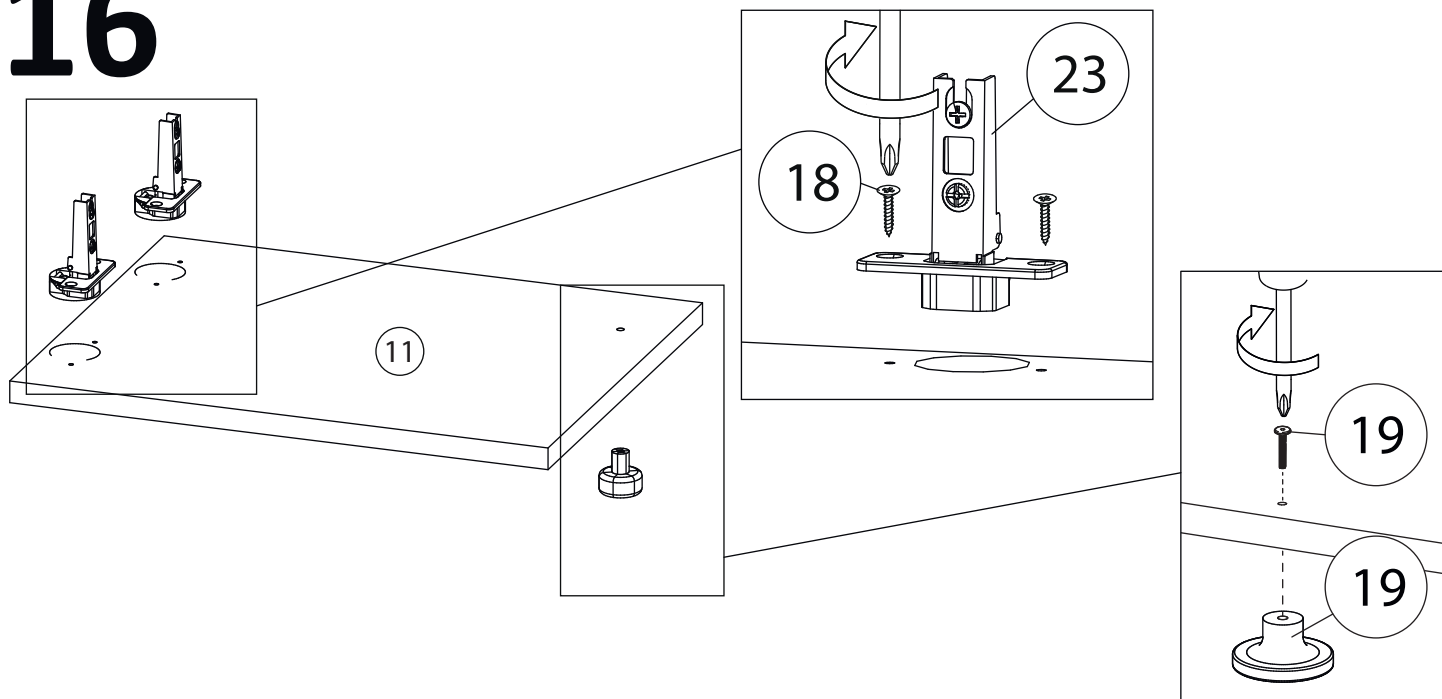

# 17

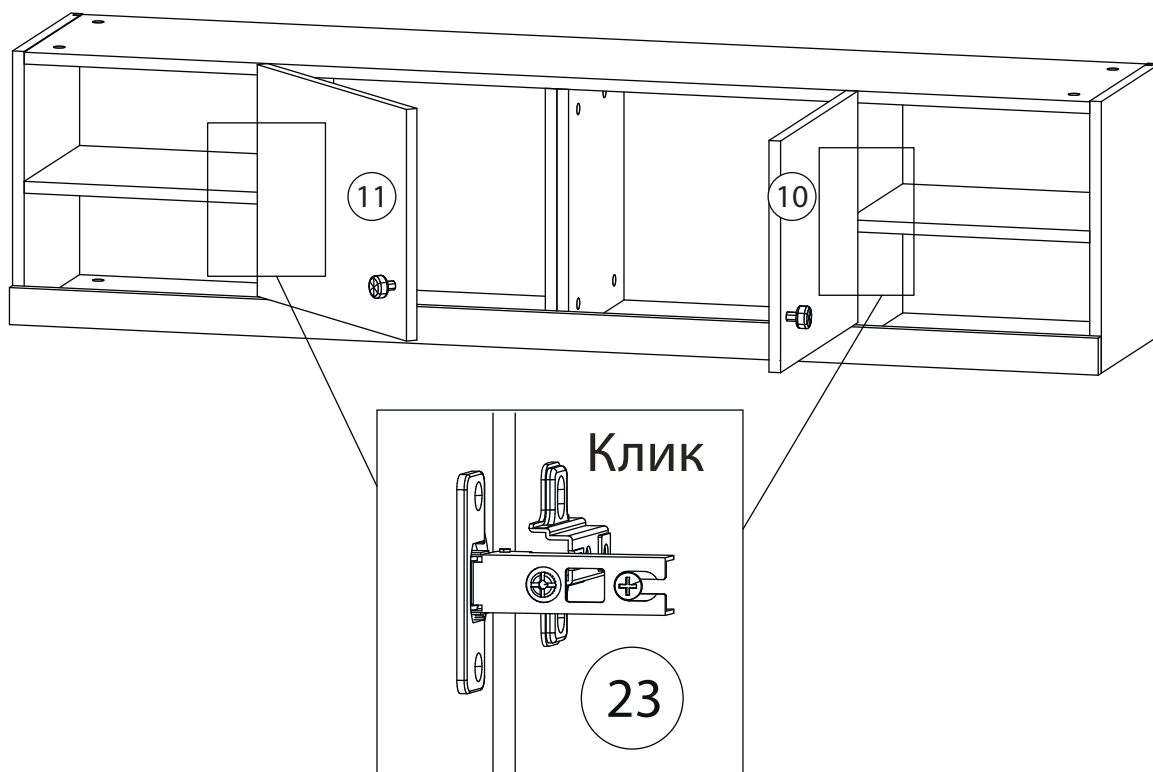

Заклеить технические отверстия заглушками.

## Регулировка петель

а - регулировка расстояния между дверью и корпусом  
 б - регулировка положения двери по-вертикали  
 в - регулировка положения ТТдвери по-горизонтали

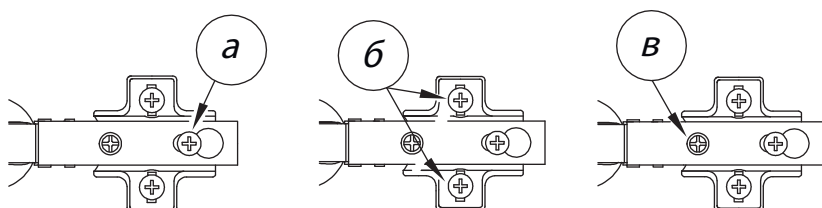

# 18

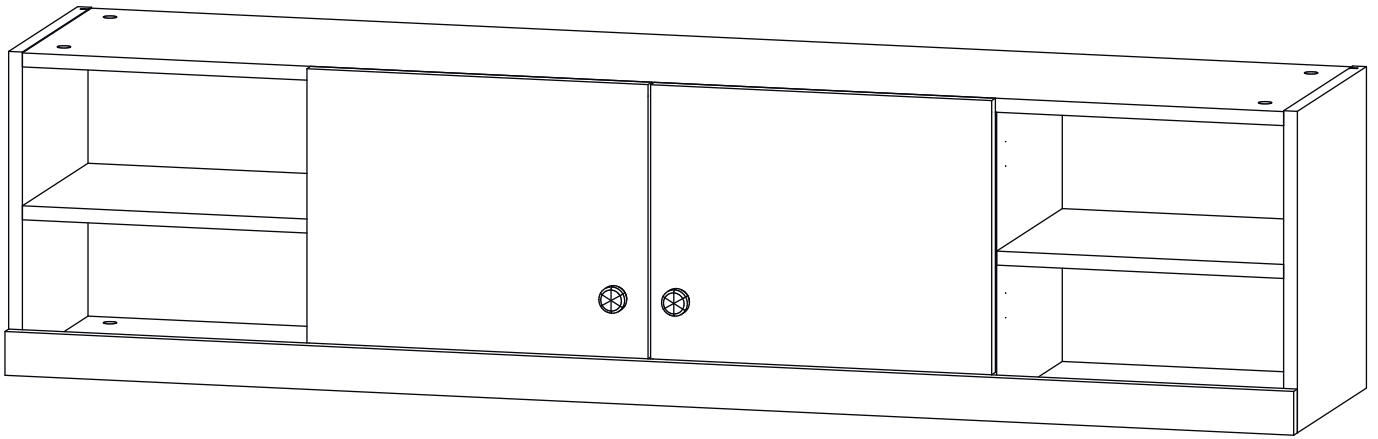

Закрепите полосу крепёжную для навеса (21) на стене горизонтально.  
Навесьте собранную полку на полосу крепёжную.

Заклеить технические  
отверстия заглушками.