

# Инструкция по сборке

Мори

Шкаф распашной - 12

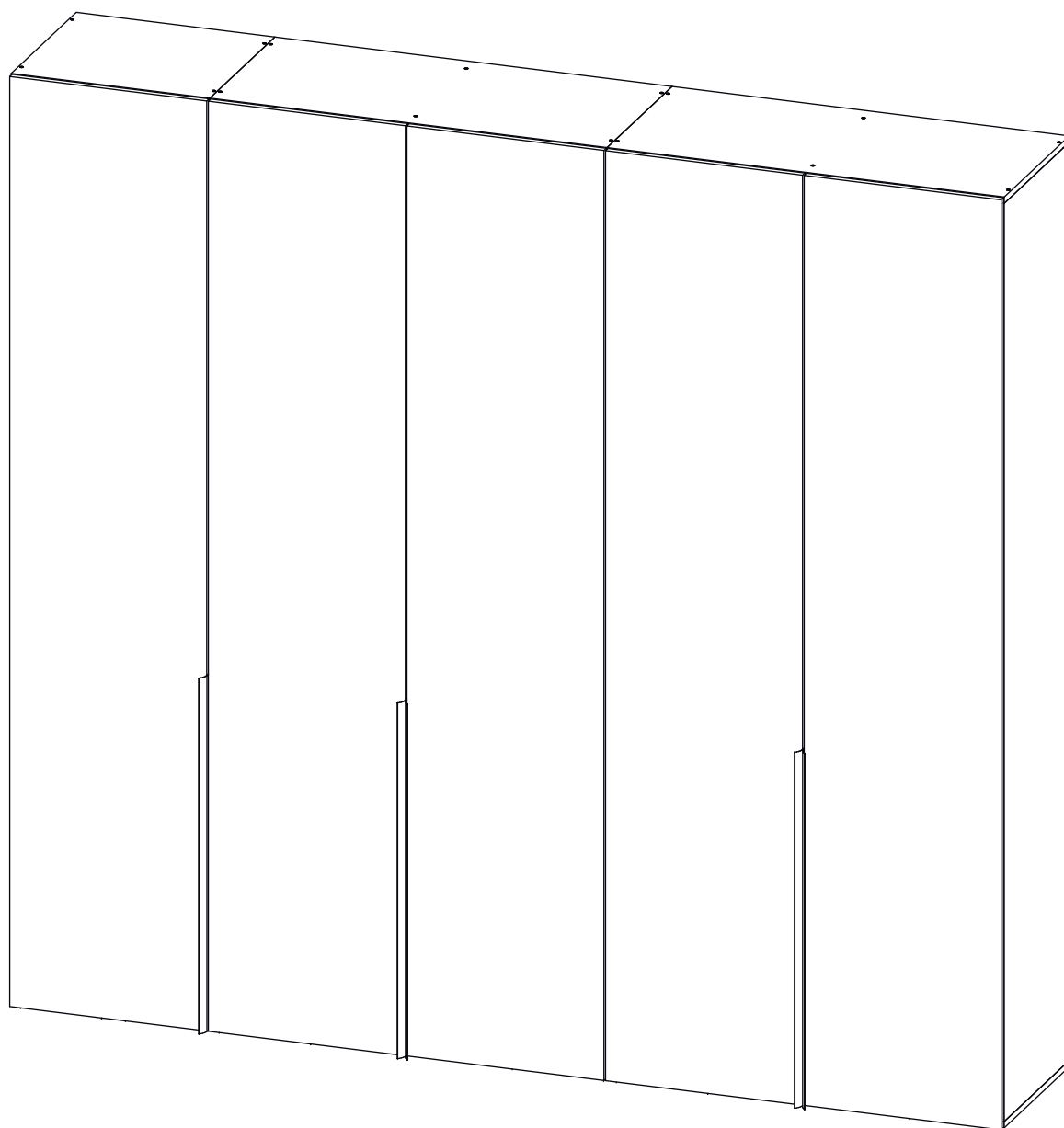

# Детали

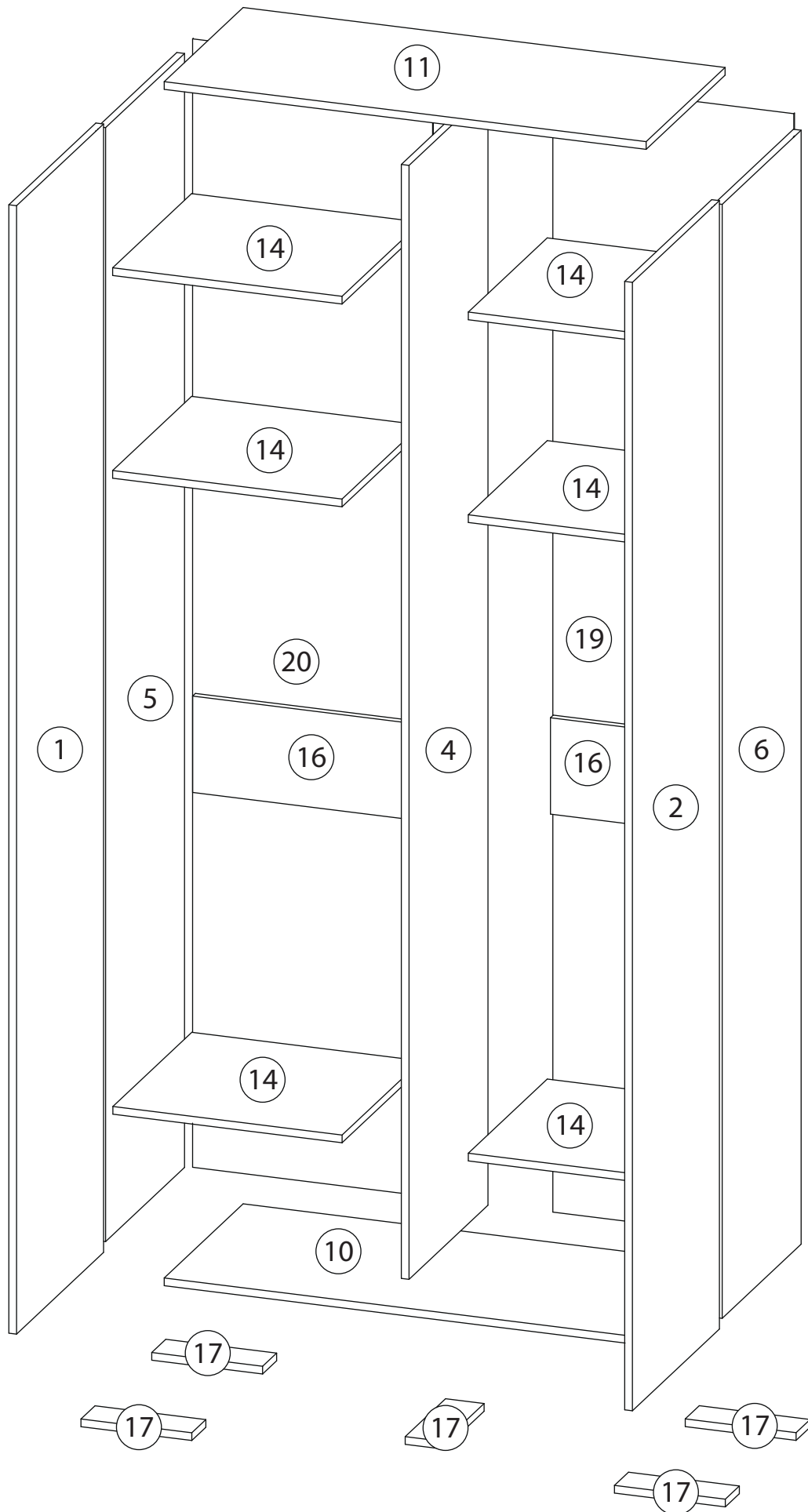

# Детали

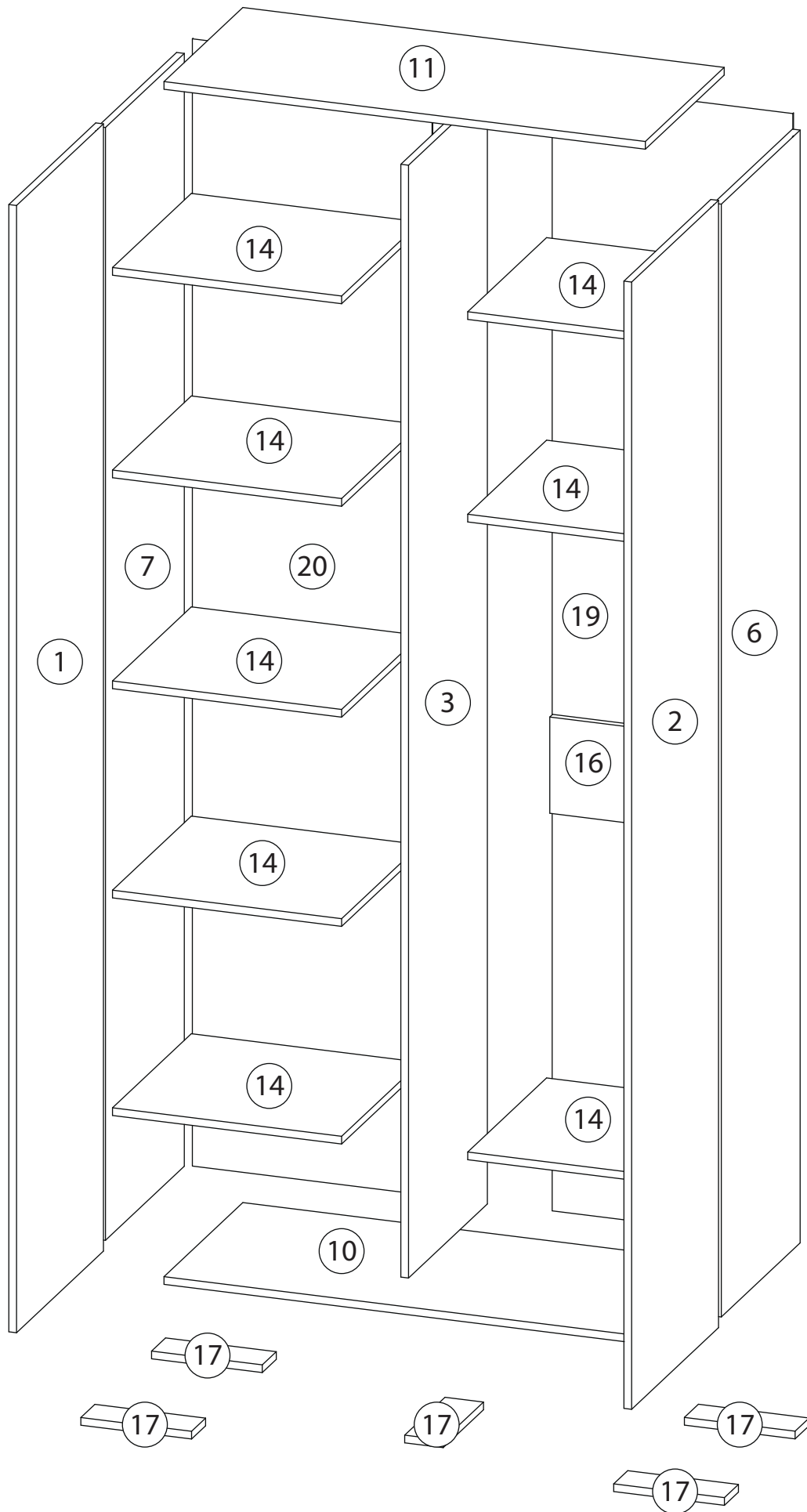



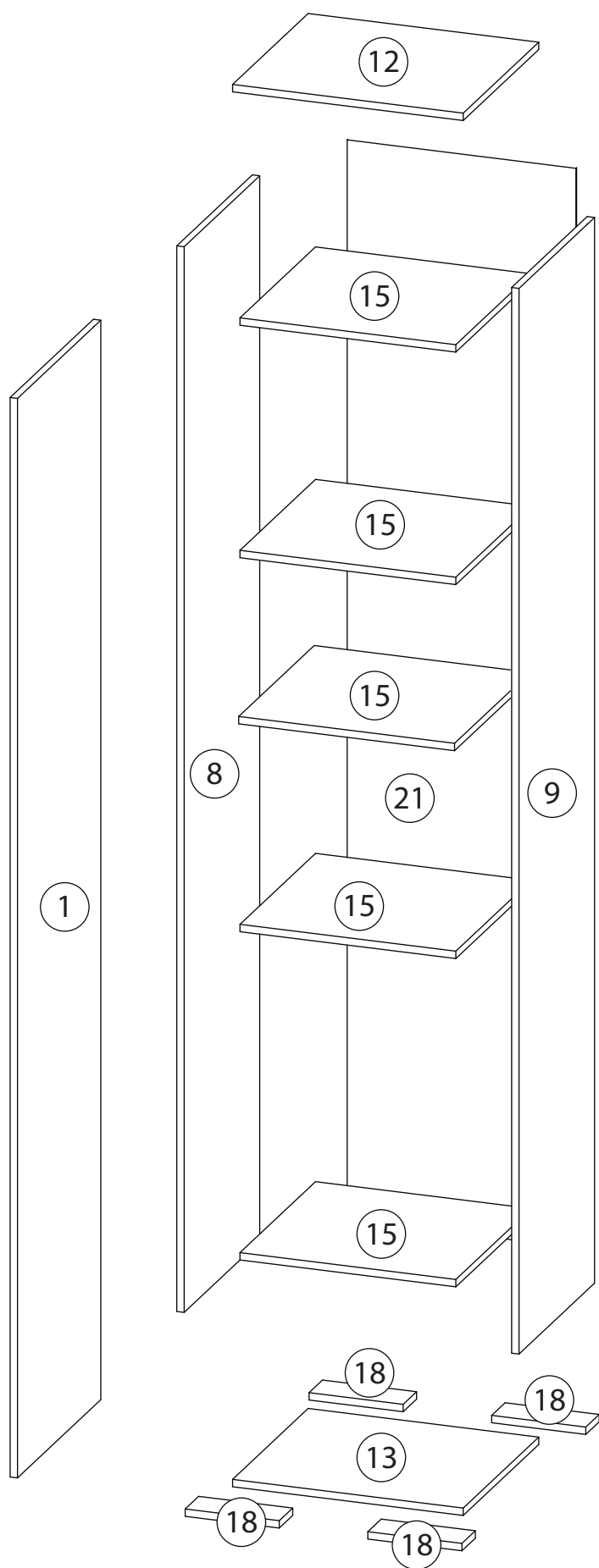

# Детали

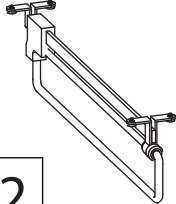
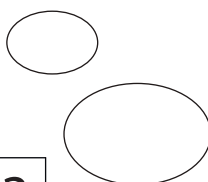
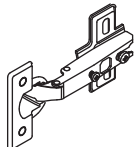
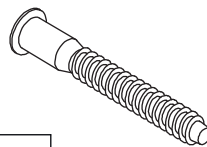
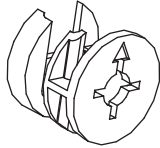
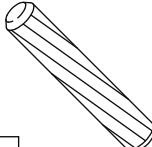
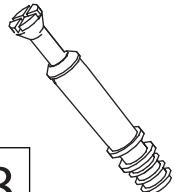

## Детали

Поз.	Наименование	Кол-во	Длина	Ширина
1	Дверь	3	2342	496
2	Дверь	2	2342	496
3	Вертикальная	1	2312	450
4	Вертикальная	1	2312	450
5	Бок правый	1	2312	450
6	Бок левый	2	2312	450
7	Бок правый	1	2312	450
8	Бок левый	1	2312	450
9	Бок правый	1	2312	450
10	Горизонтальная	2	1000	450
11	Крыша	2	1000	450
12	Крыша	1	500	450
13	Горизонтальная	1	500	450
14	Полка	14	476	450
15	Полка	5	468	450
16	Ребро жесткости	3	476	200
17	Горизонтальная	10	230	80
18	Горизонтальная	4	204	80
19	Задняя стенка	2	2342	500
20	Задняя стенка	2	2342	498
21	Задняя стенка	1	2342	496

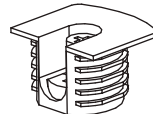
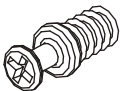
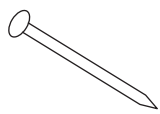
# Фурнитура

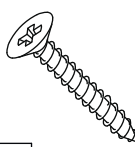
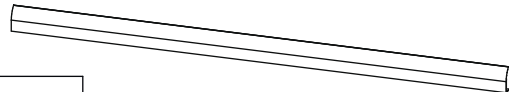
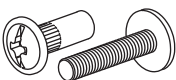
				
<p>22</p> <p><u>Штанга выдвигающая</u></p>	<p>23</p> <p><u>Заглушка</u> <u>Ø13-20</u></p>	<p>24</p> <p><u>Петля накладная</u></p>	<p>25</p> <p><u>Евровинт 7x50</u></p>	<p>26</p> <p><u>Эксцентрик</u></p>
				
<p>27</p> <p><u>Шкант бук</u></p>	<p>28</p> <p><u>Шток эксцентрика</u></p>	<p>29</p> <p><u>Евровинт 6,3x13</u></p>	<p>30</p> <p><u>Стяжка VB35</u></p>	<p>31</p> <p><u>Винт для стяжки</u> <u>VB35</u></p>
				
<p>32</p> <p><u>Гвоздь 1,6x25</u></p>	<p>33</p> <p><u>Саморез 3,5x16</u></p>	<p>34</p> <p><u>Саморез 3,5x30</u></p>	<p>35</p> <p><u>Ручка</u></p>	
				
<p>36</p> <p><u>Стяжка межсекционная</u></p>				

# 1

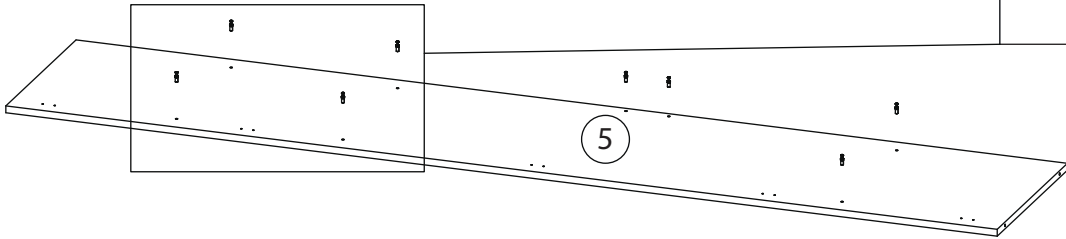
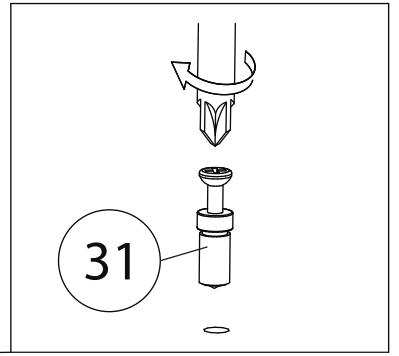

# 2

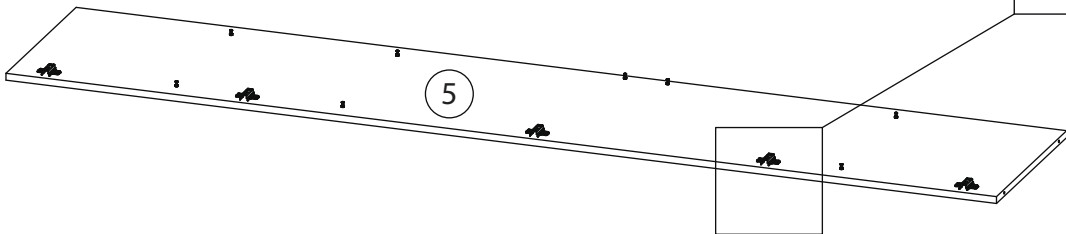
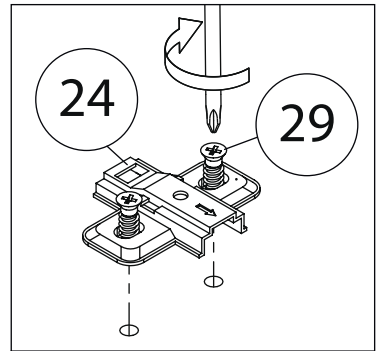

# 3

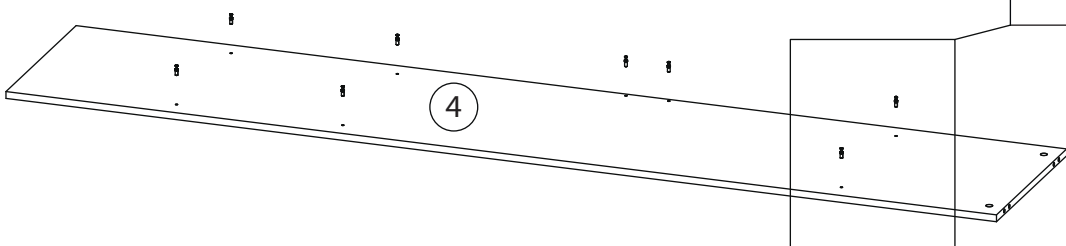
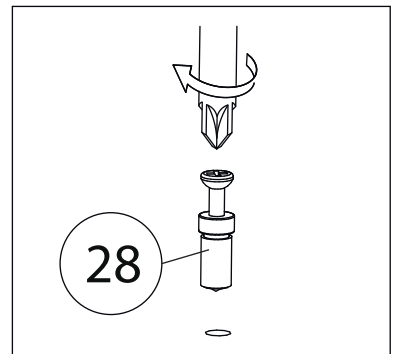

# 4

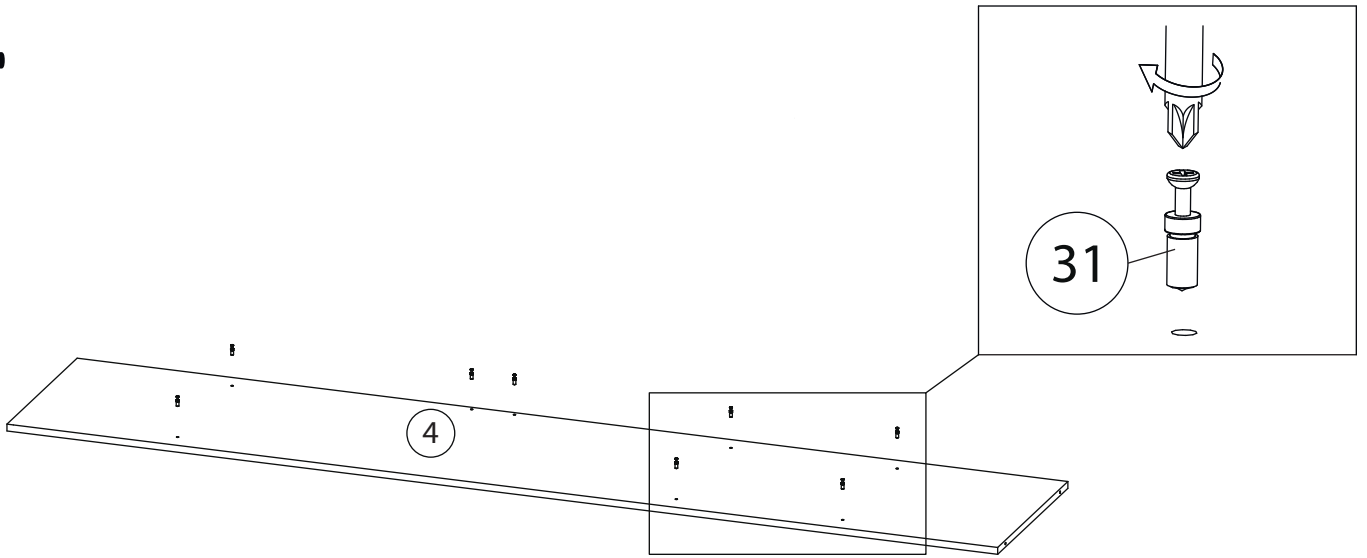

# 5

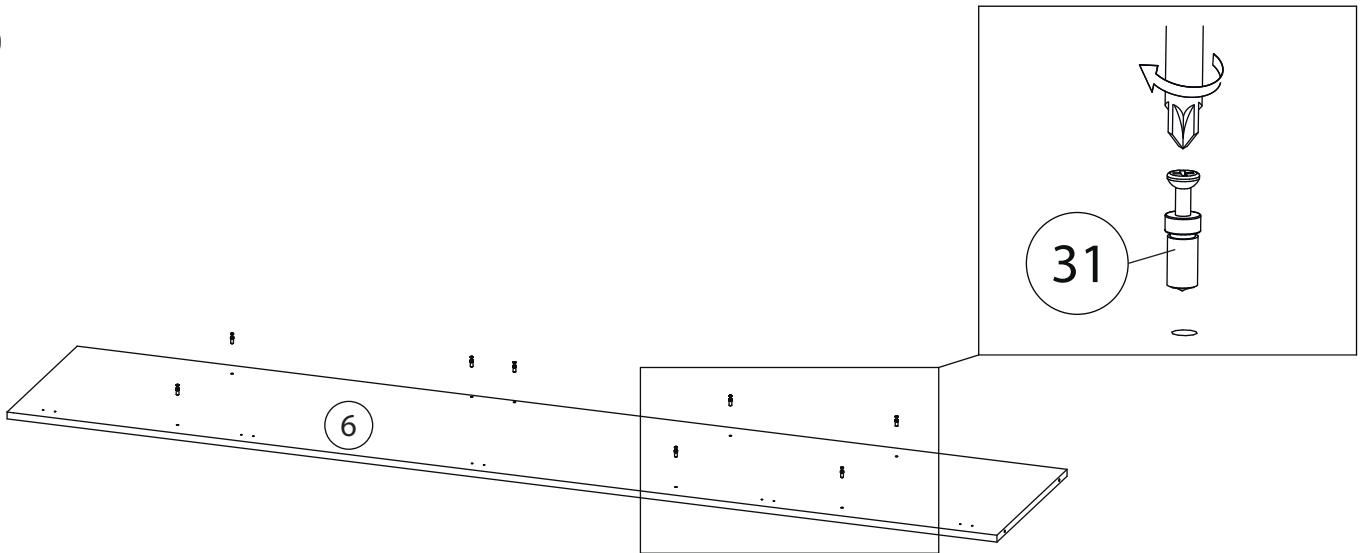

# 6

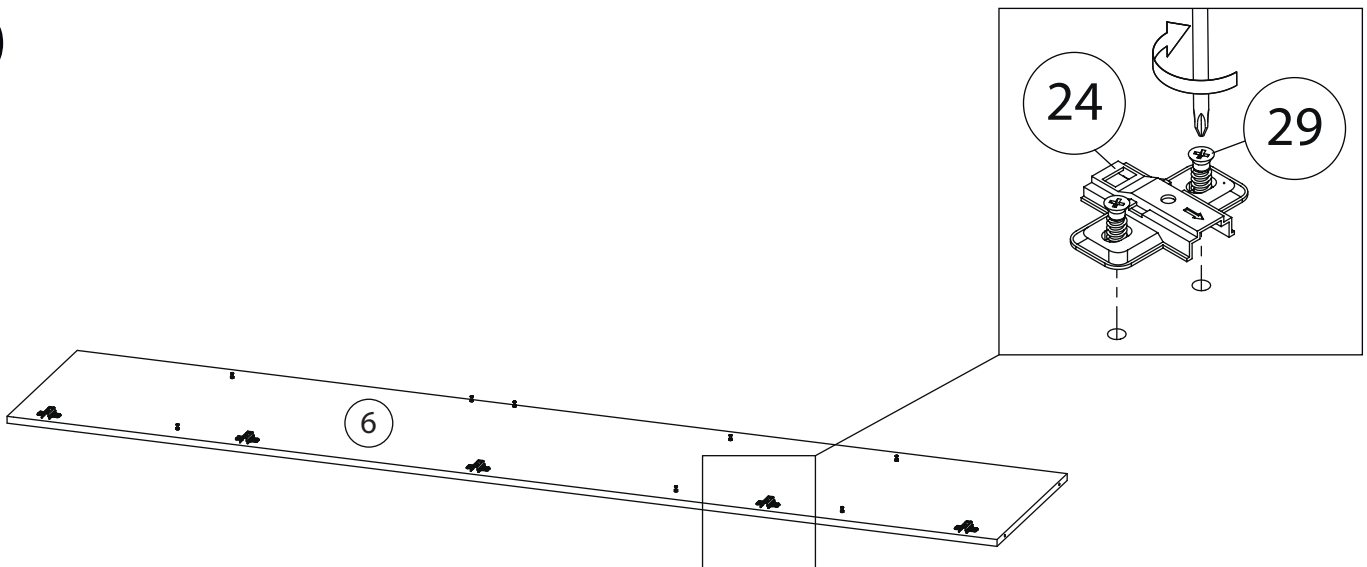

# 7

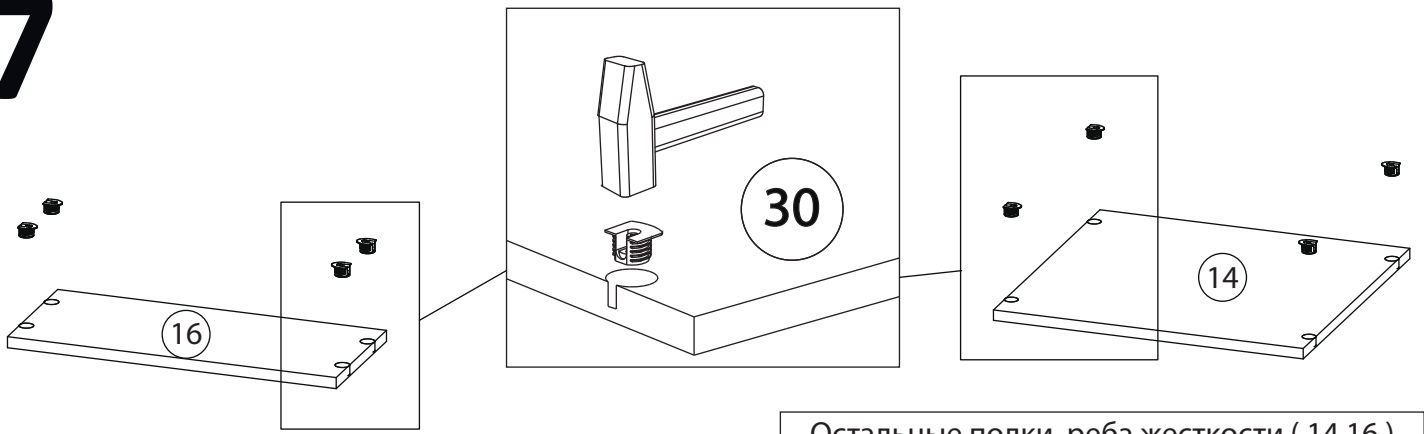

Остальные полки, ребра жесткости ( 14,16 )  
собираются аналогично

# 8

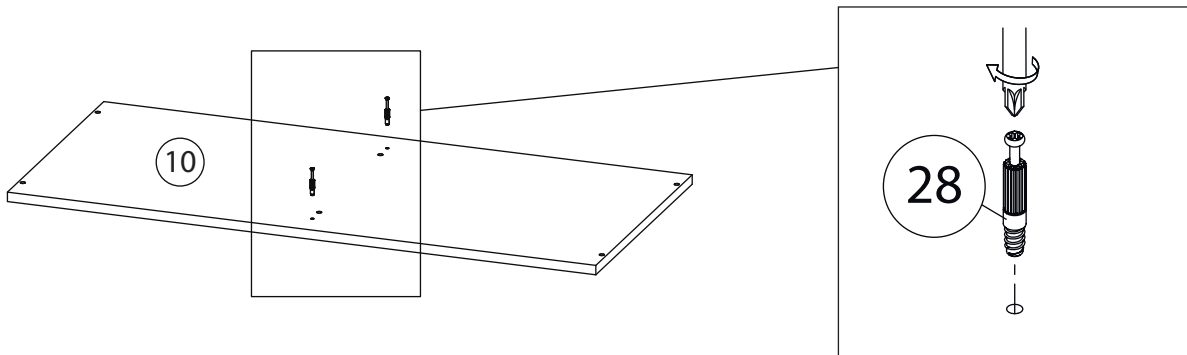

# 9

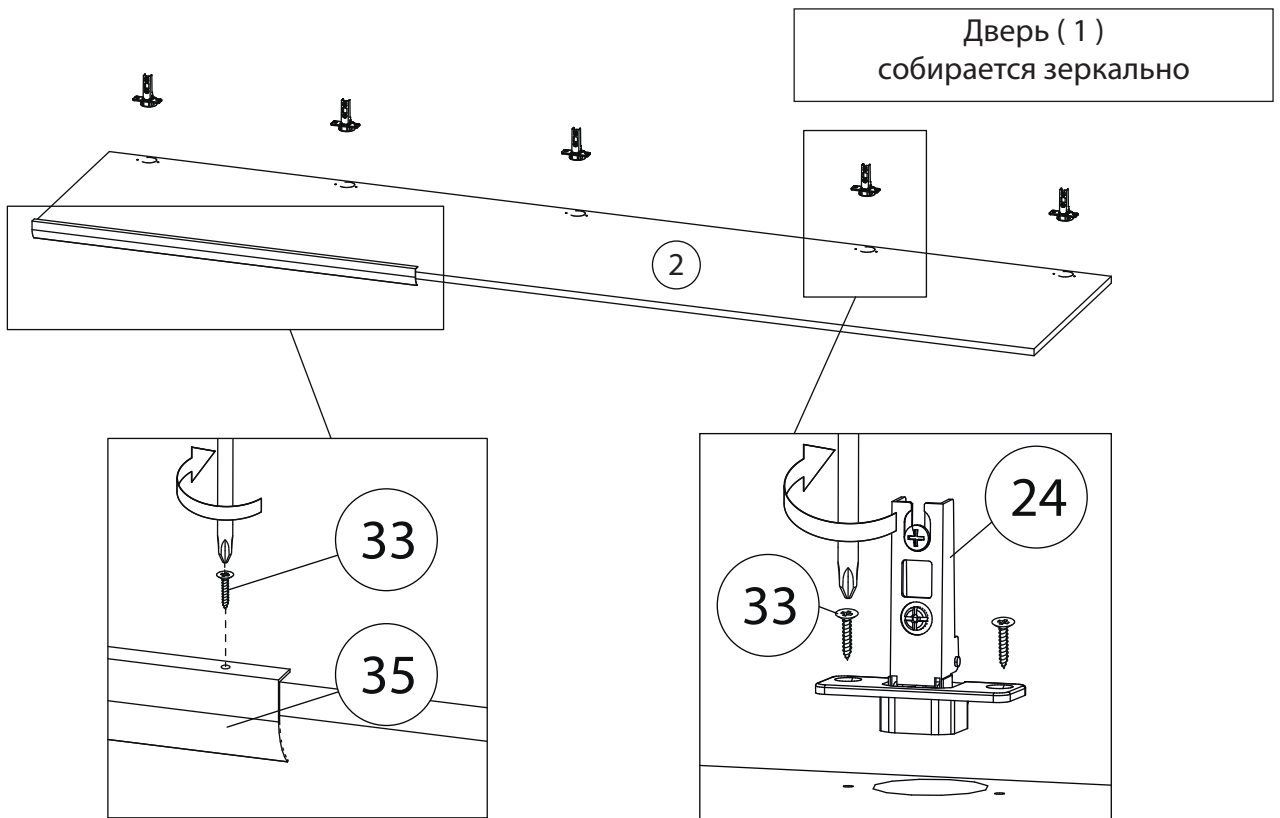

# 10

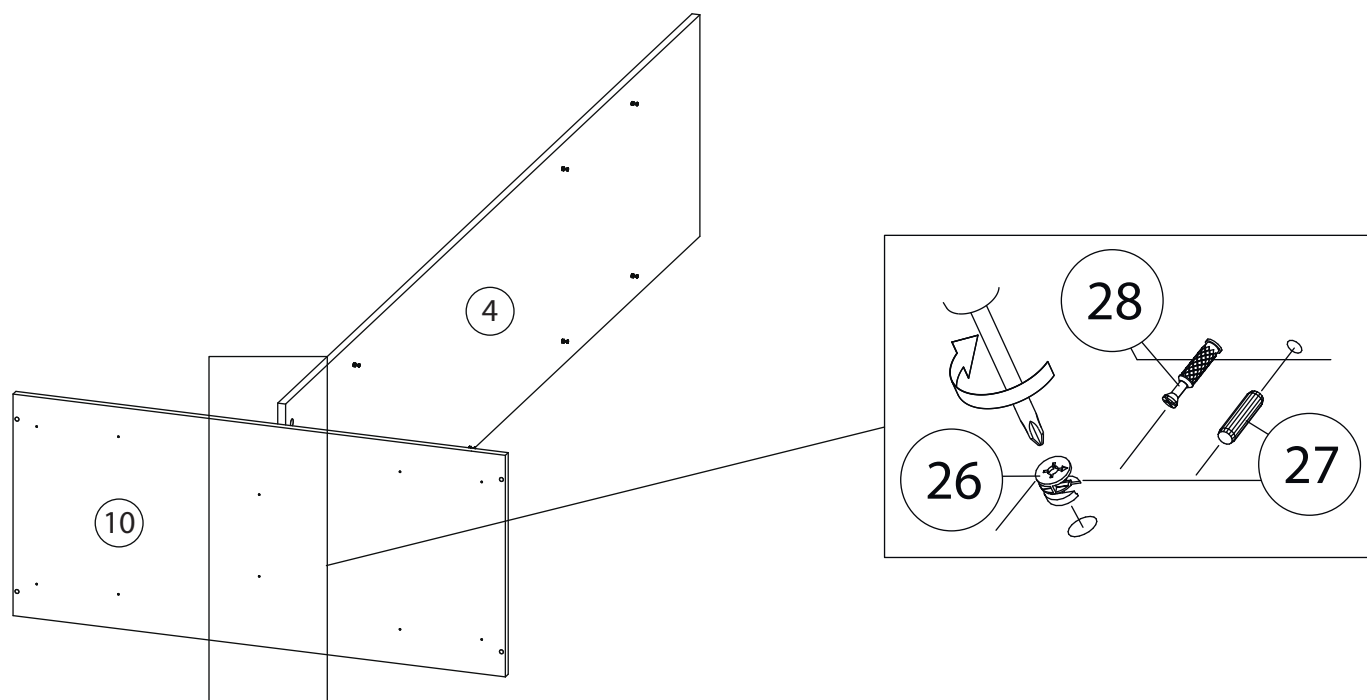

# 11

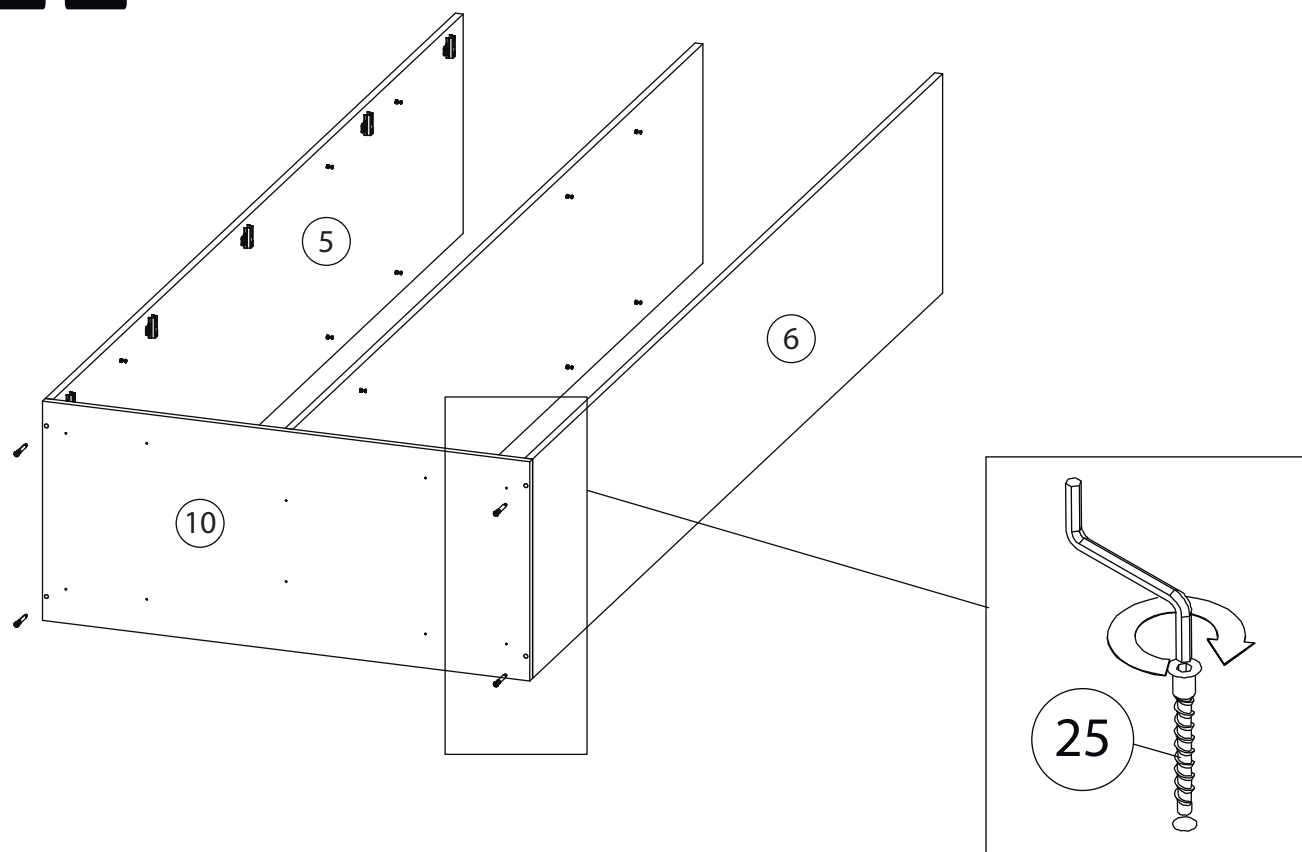

# 12

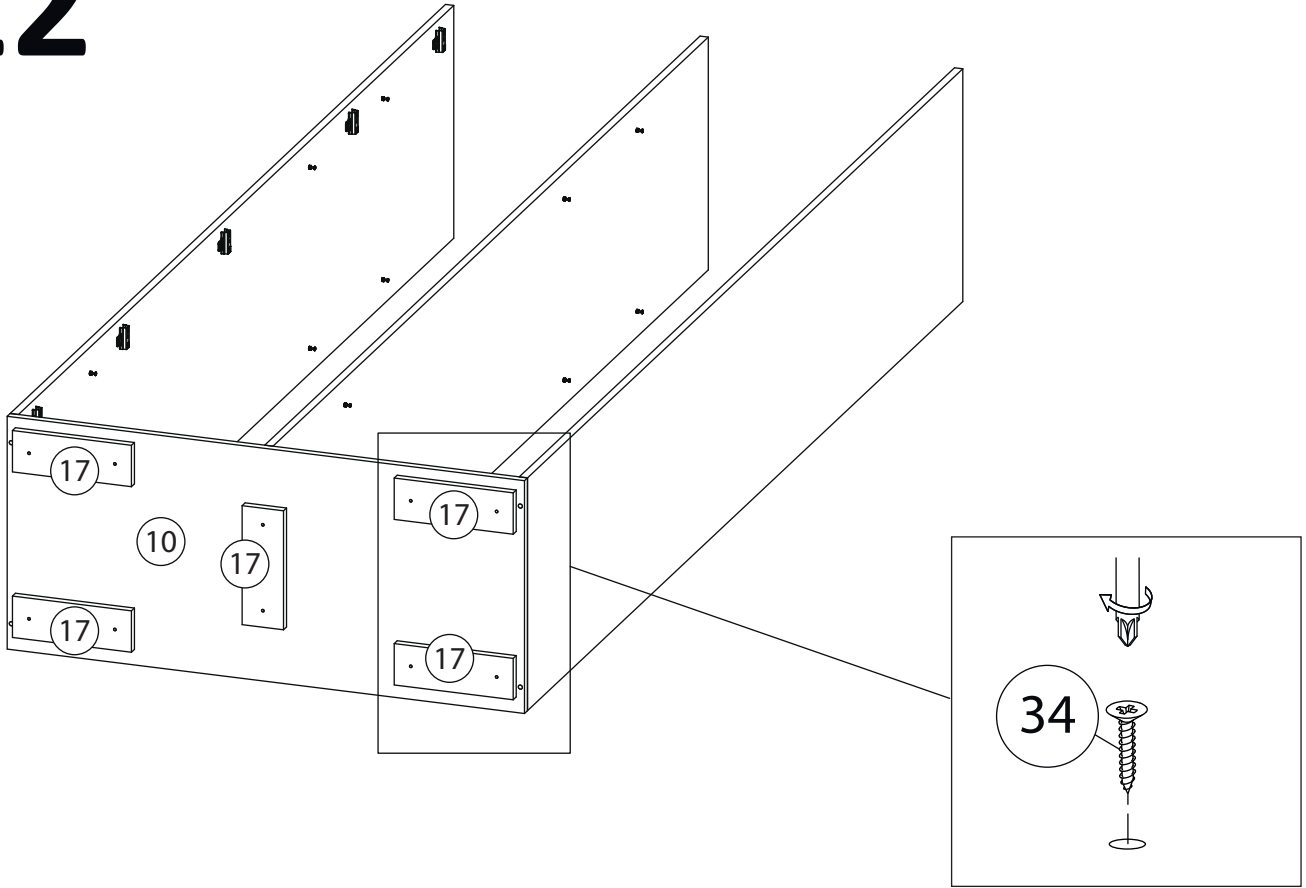

# 13

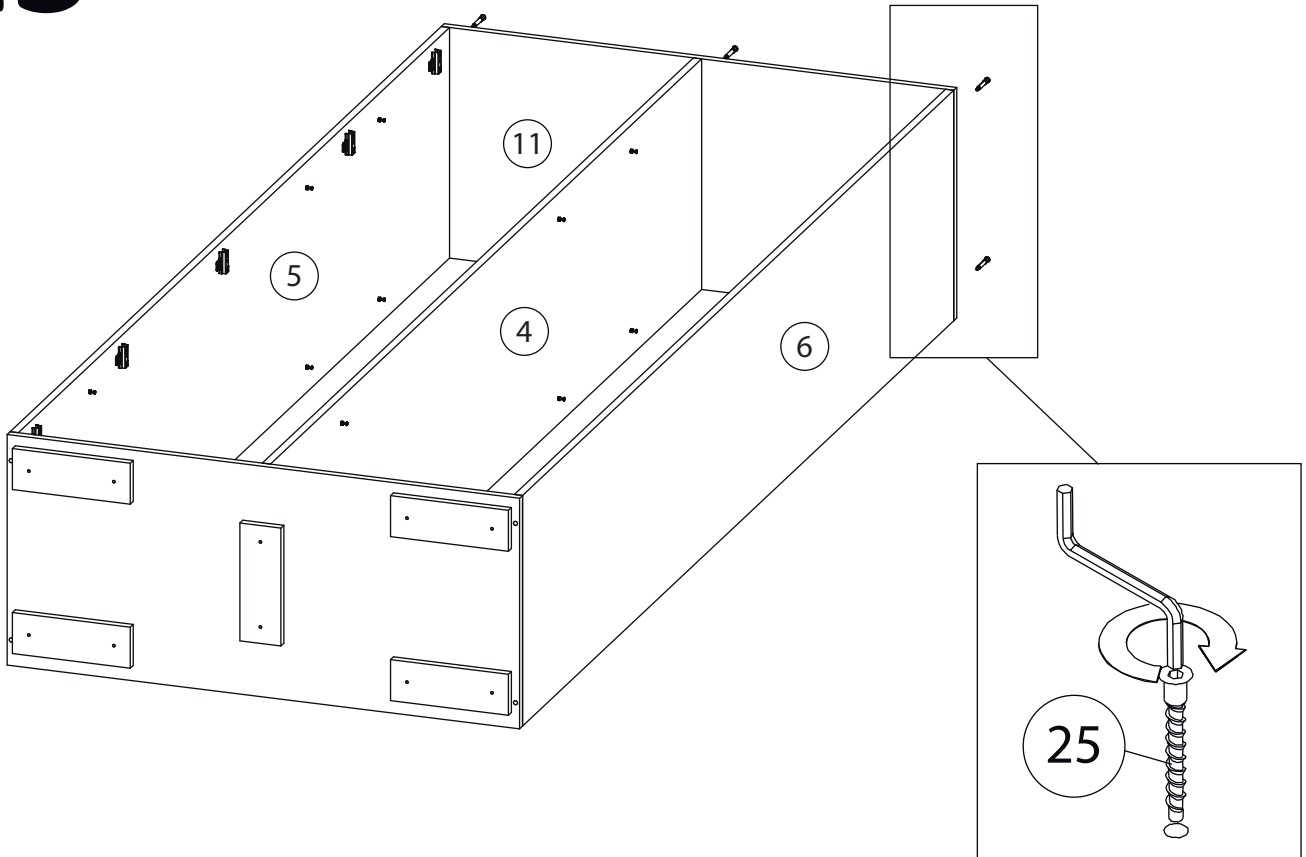

# 14

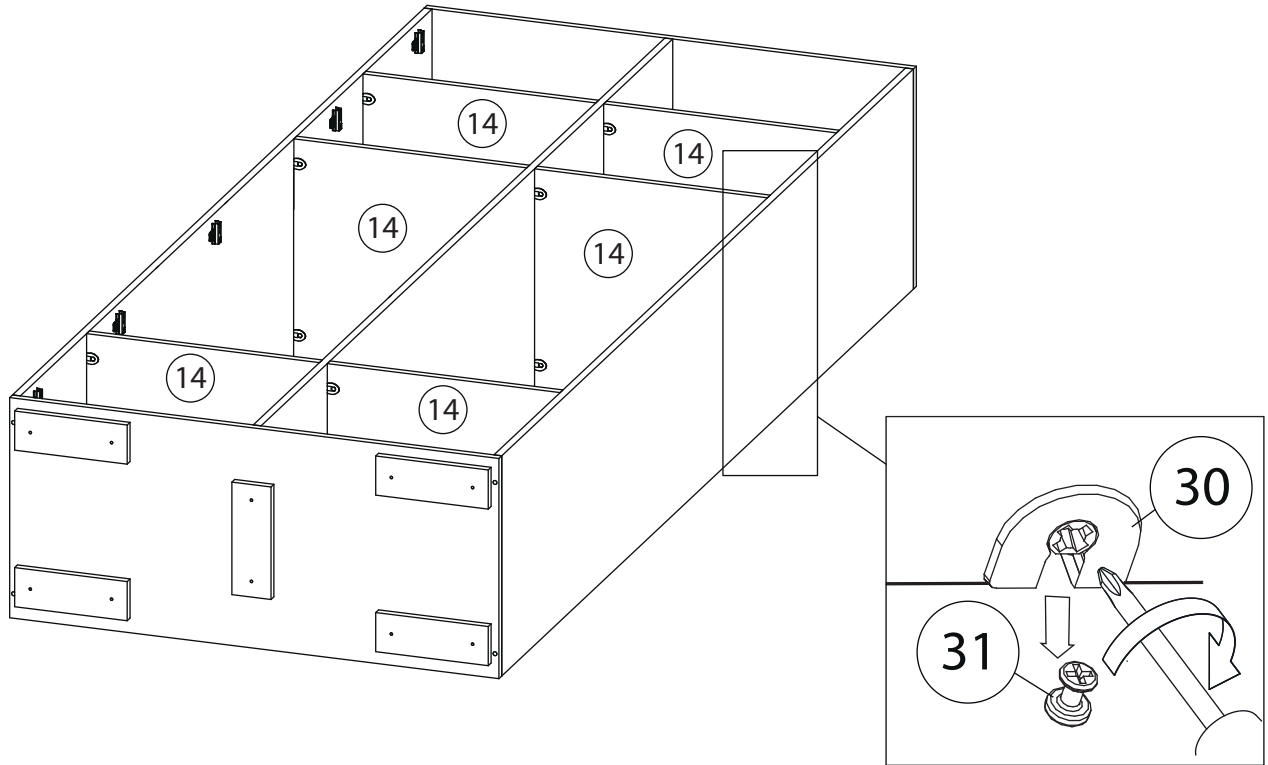

# 15

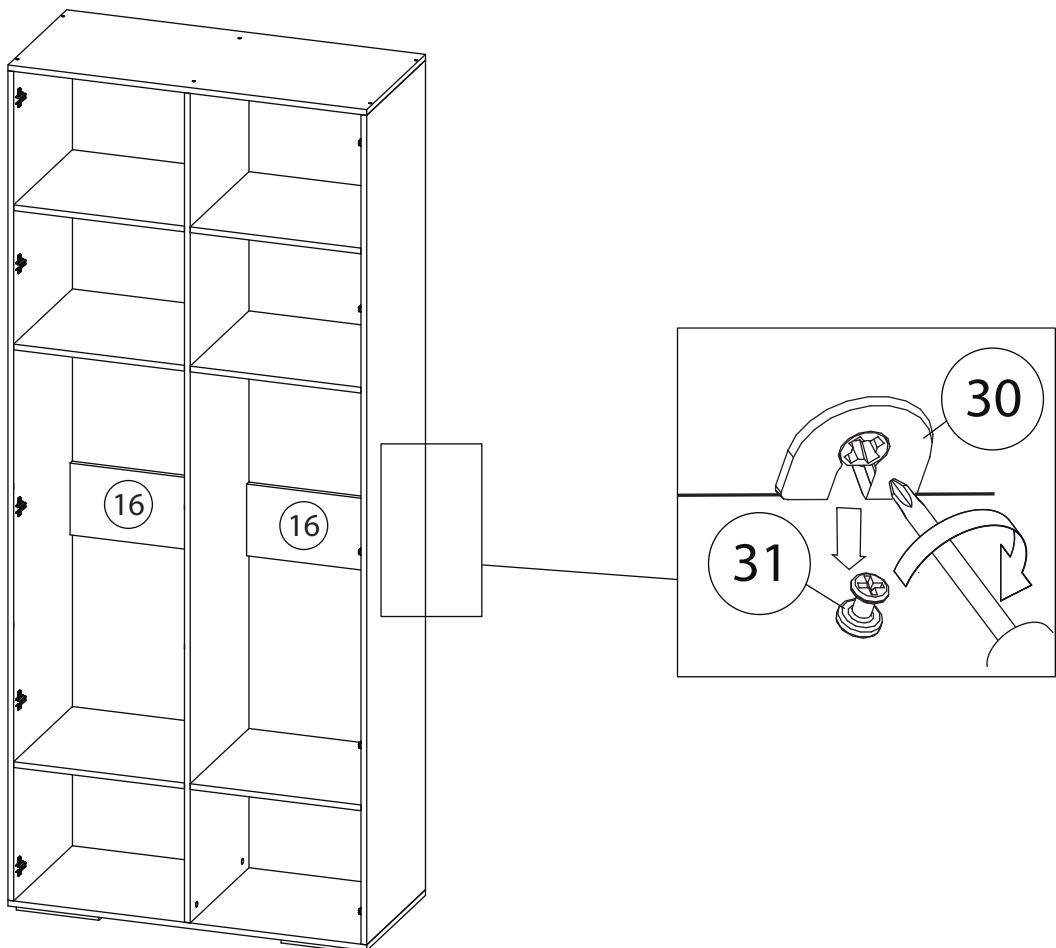

# 16

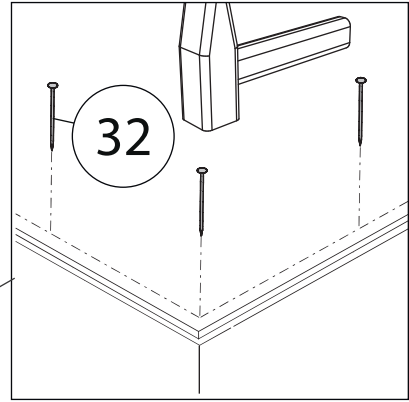
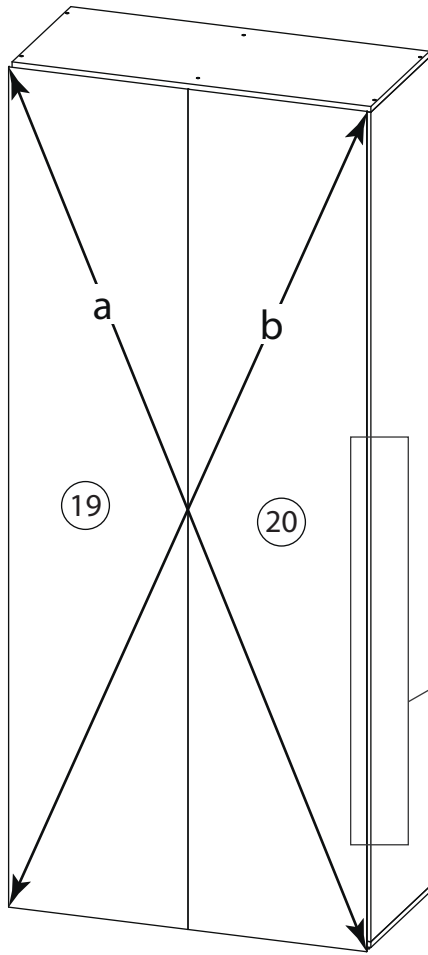

# 17

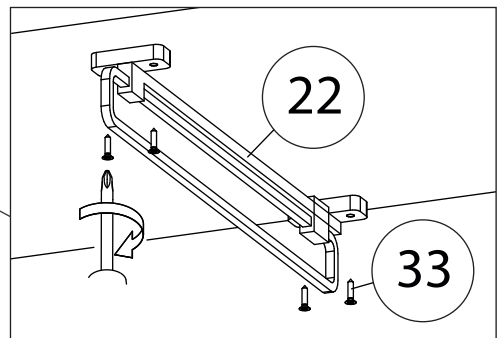
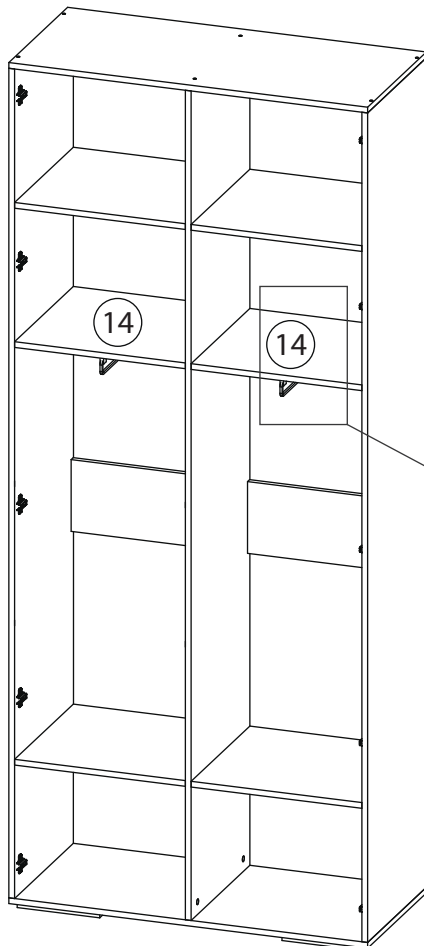

# 18

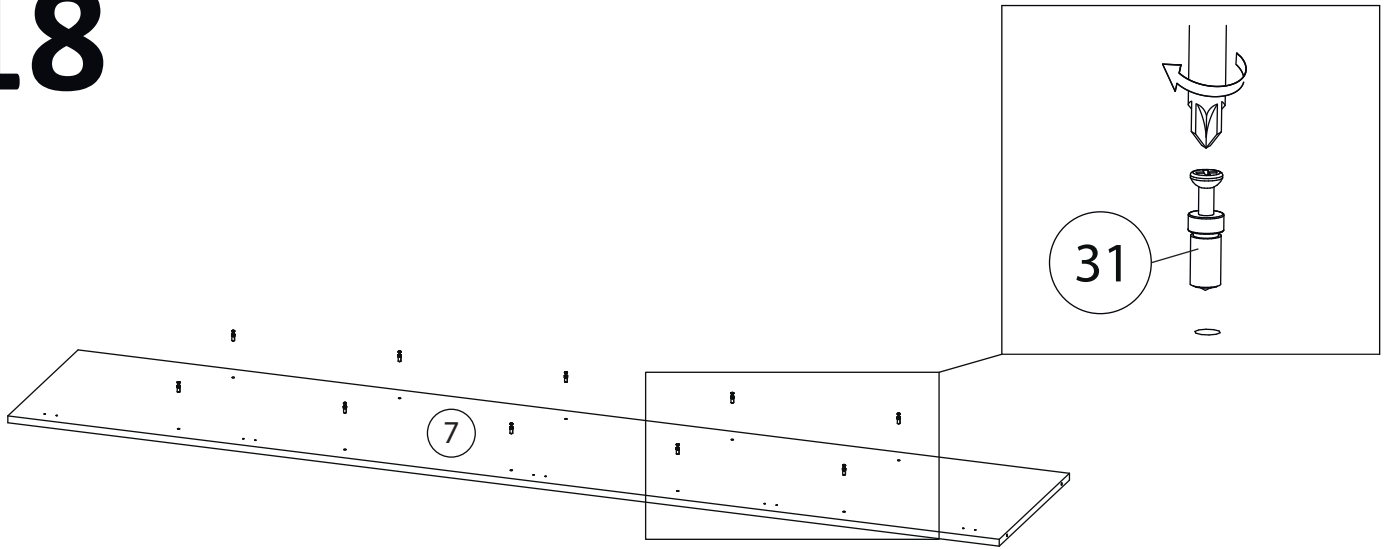

# 19

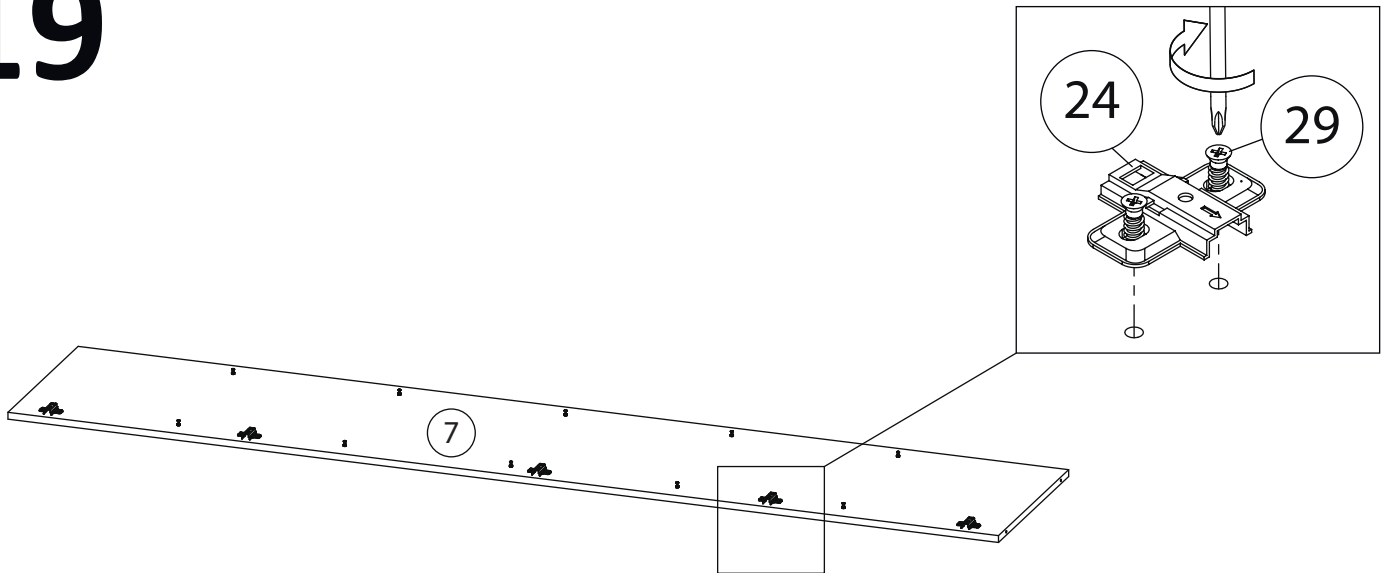

# 20

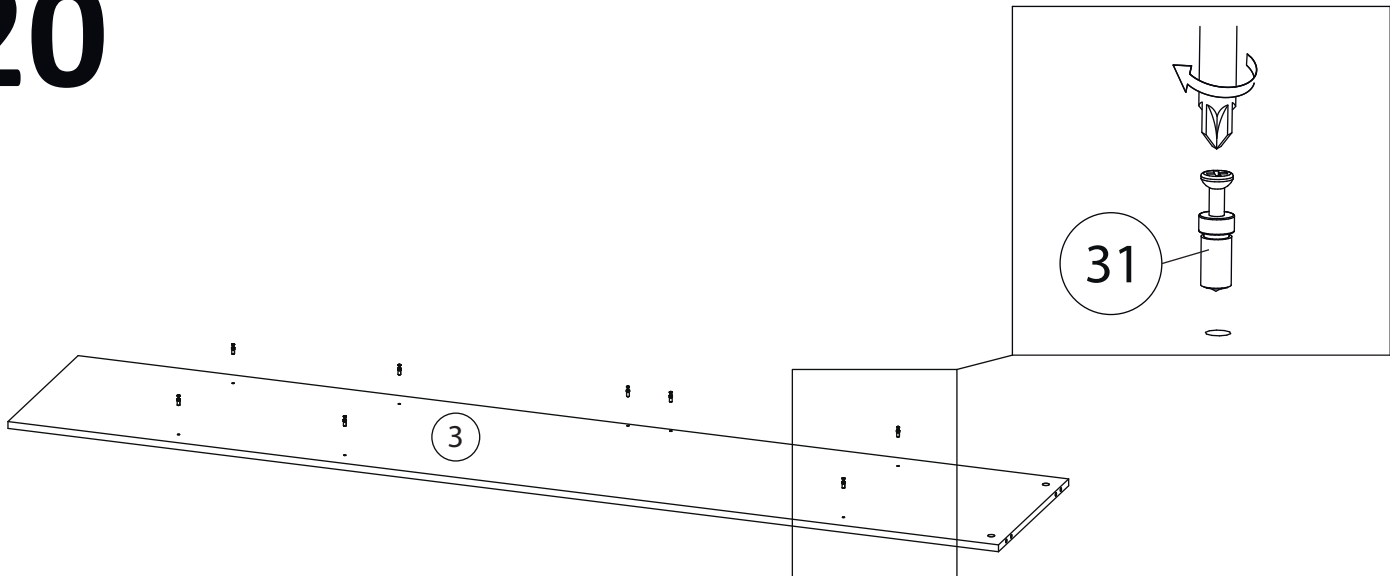

# 21

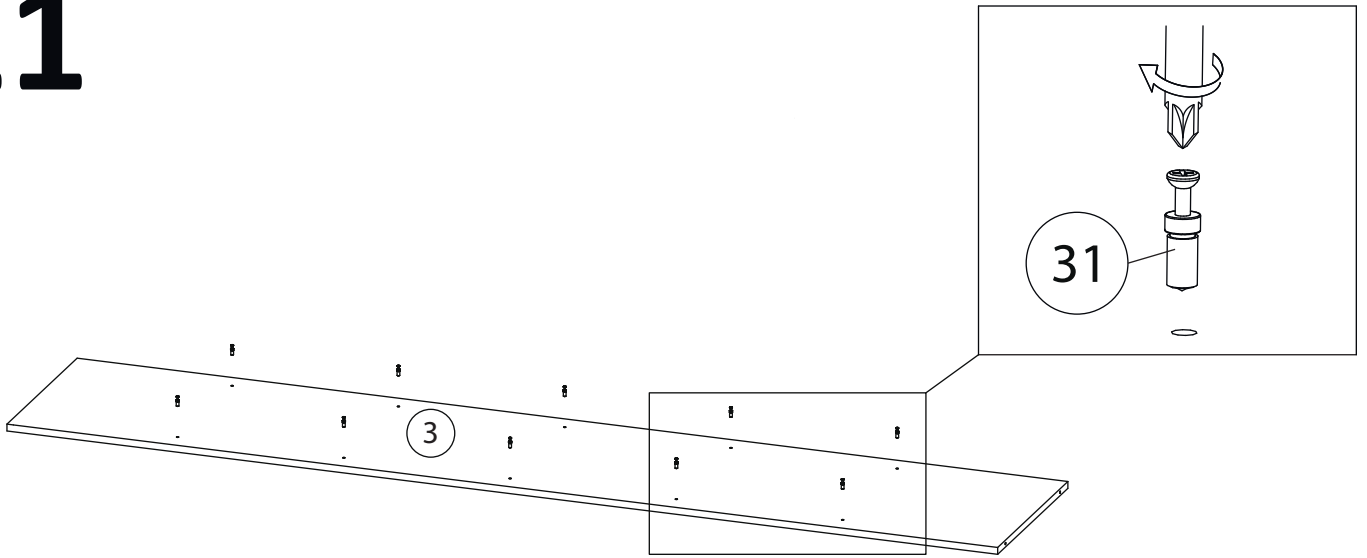

# 22

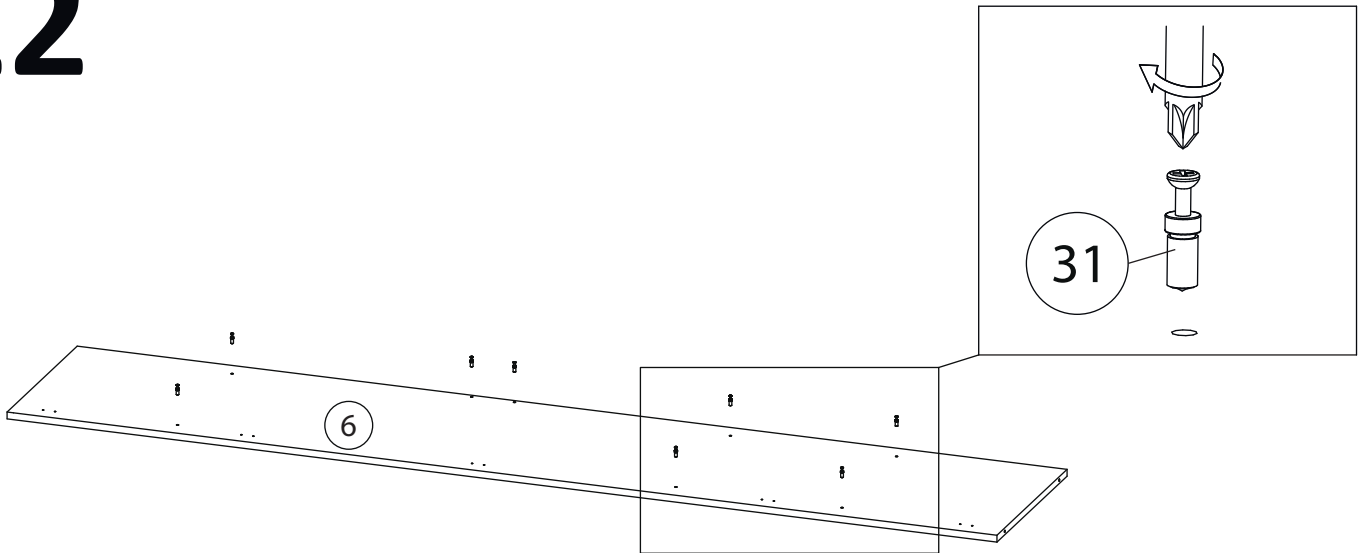

# 23

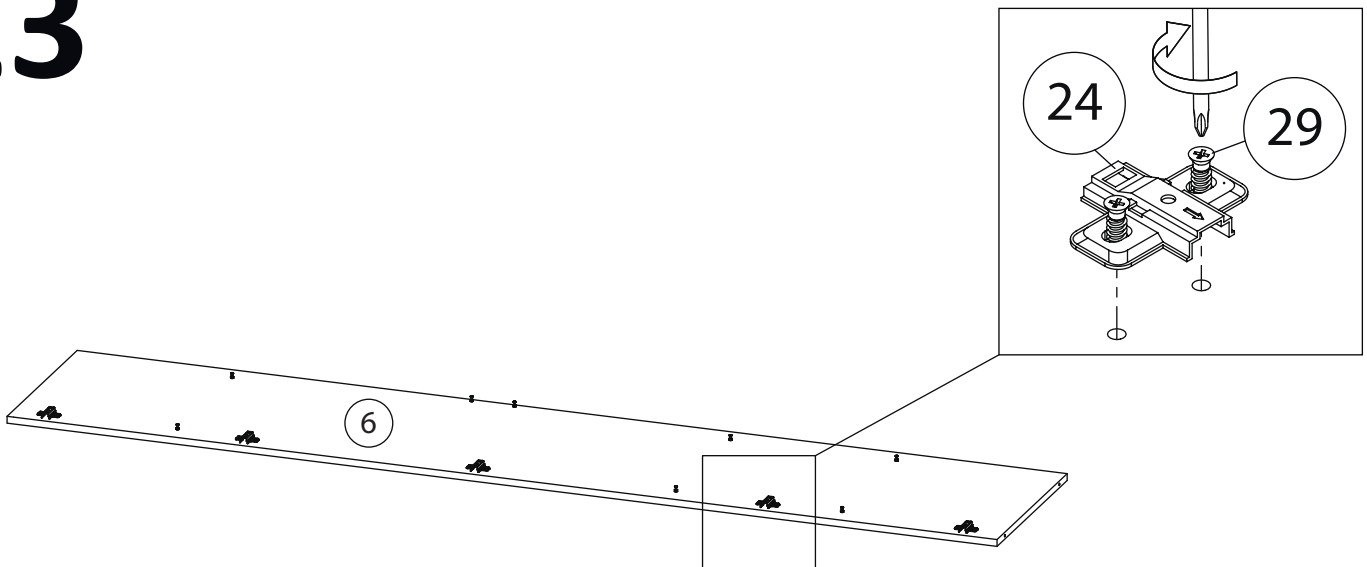

# 24

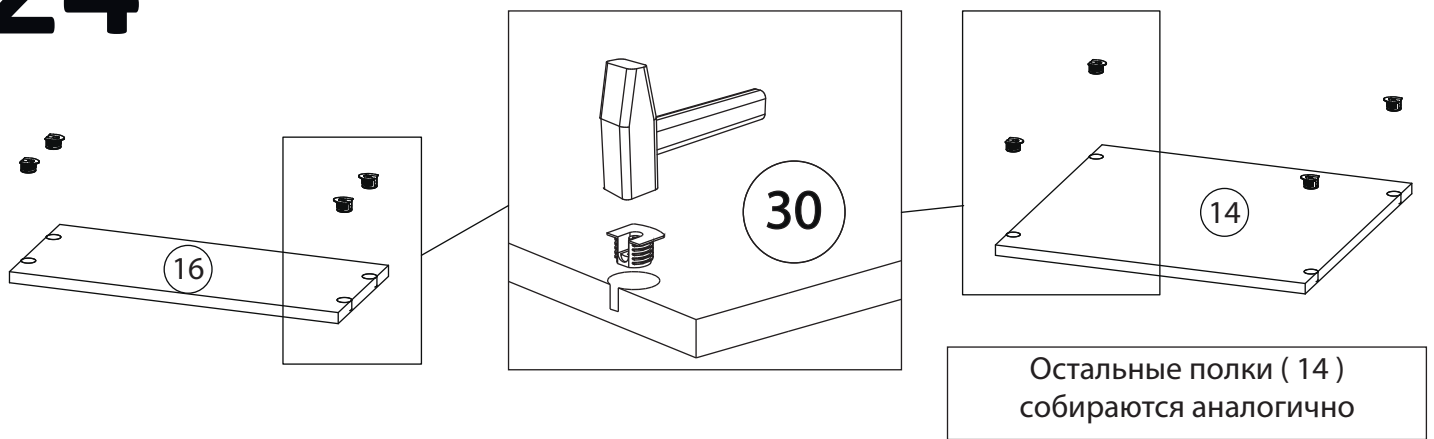

# 25

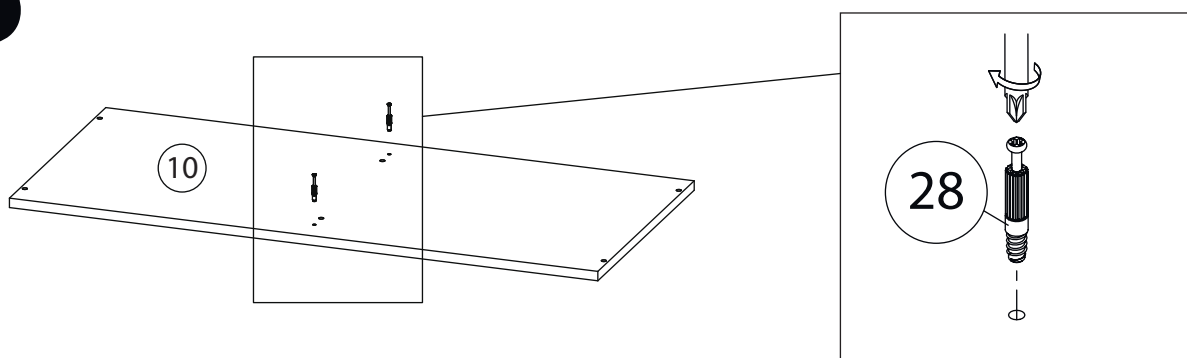

# 26

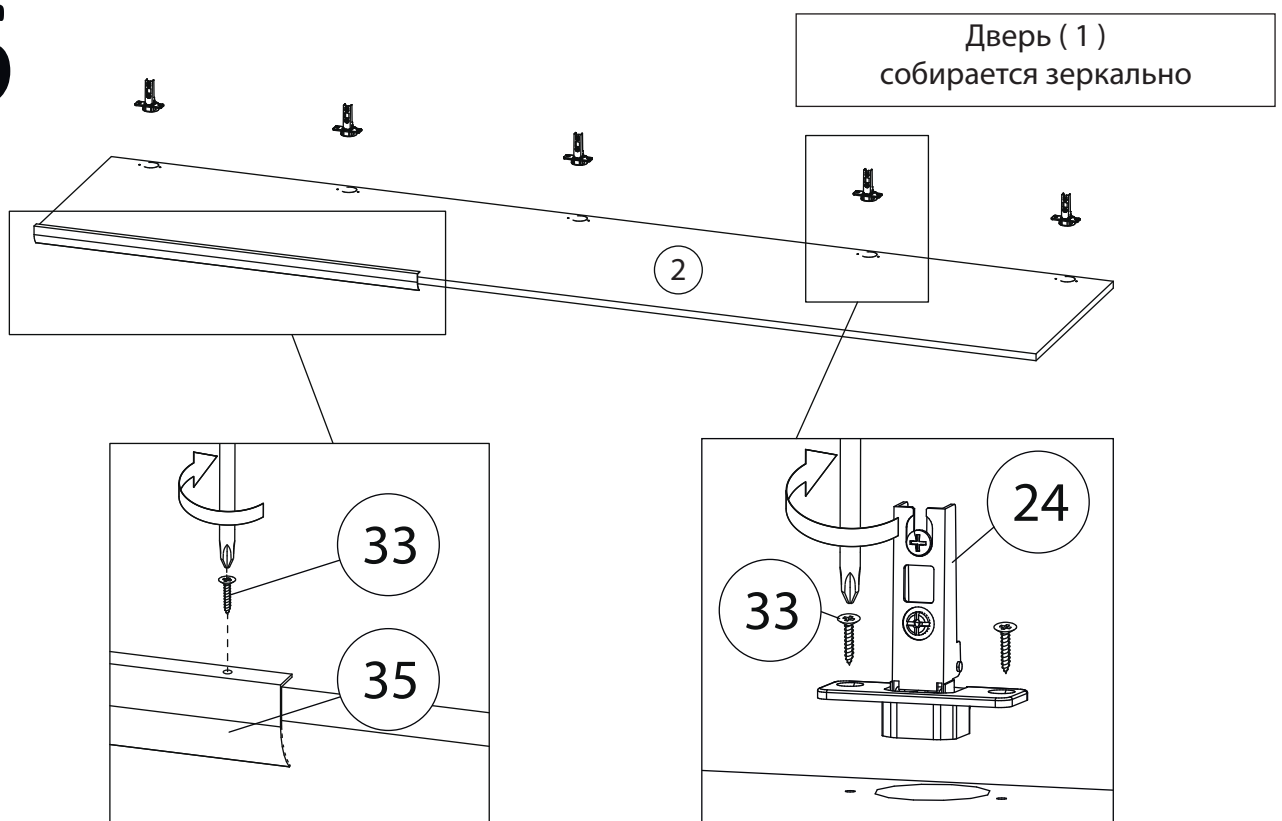

# 27

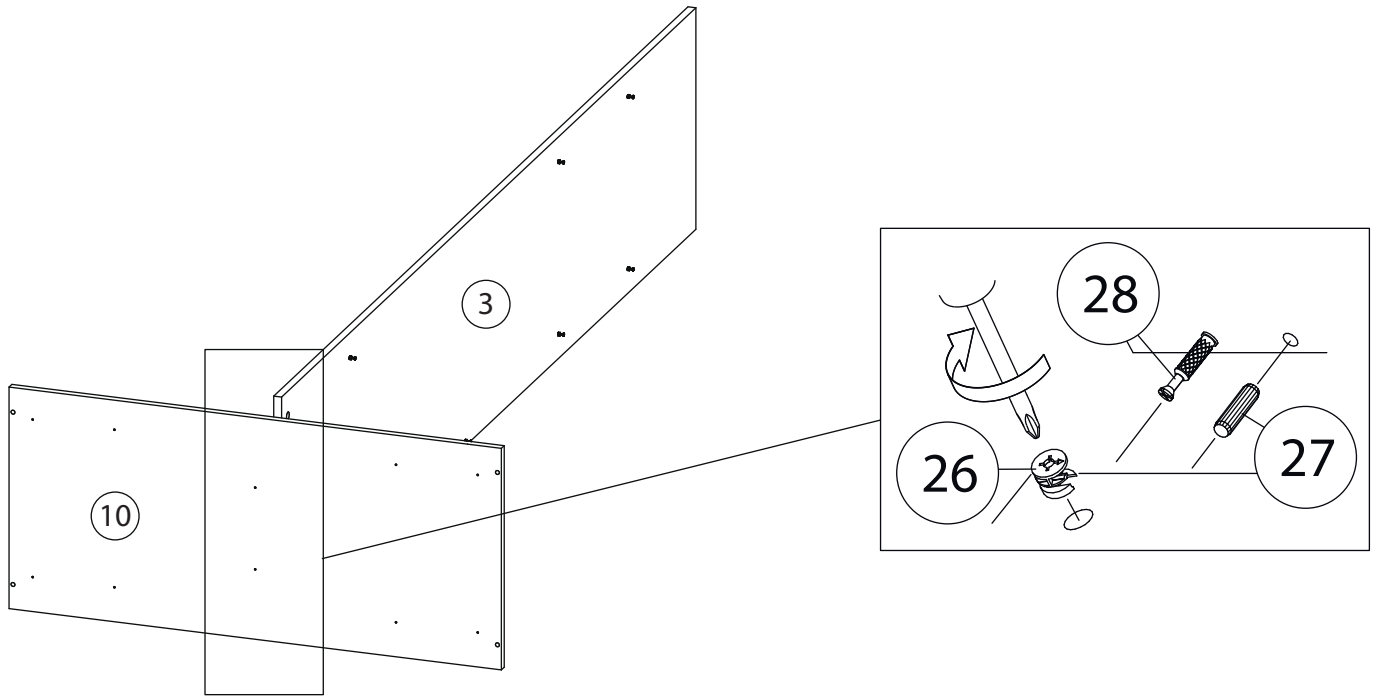

# 28

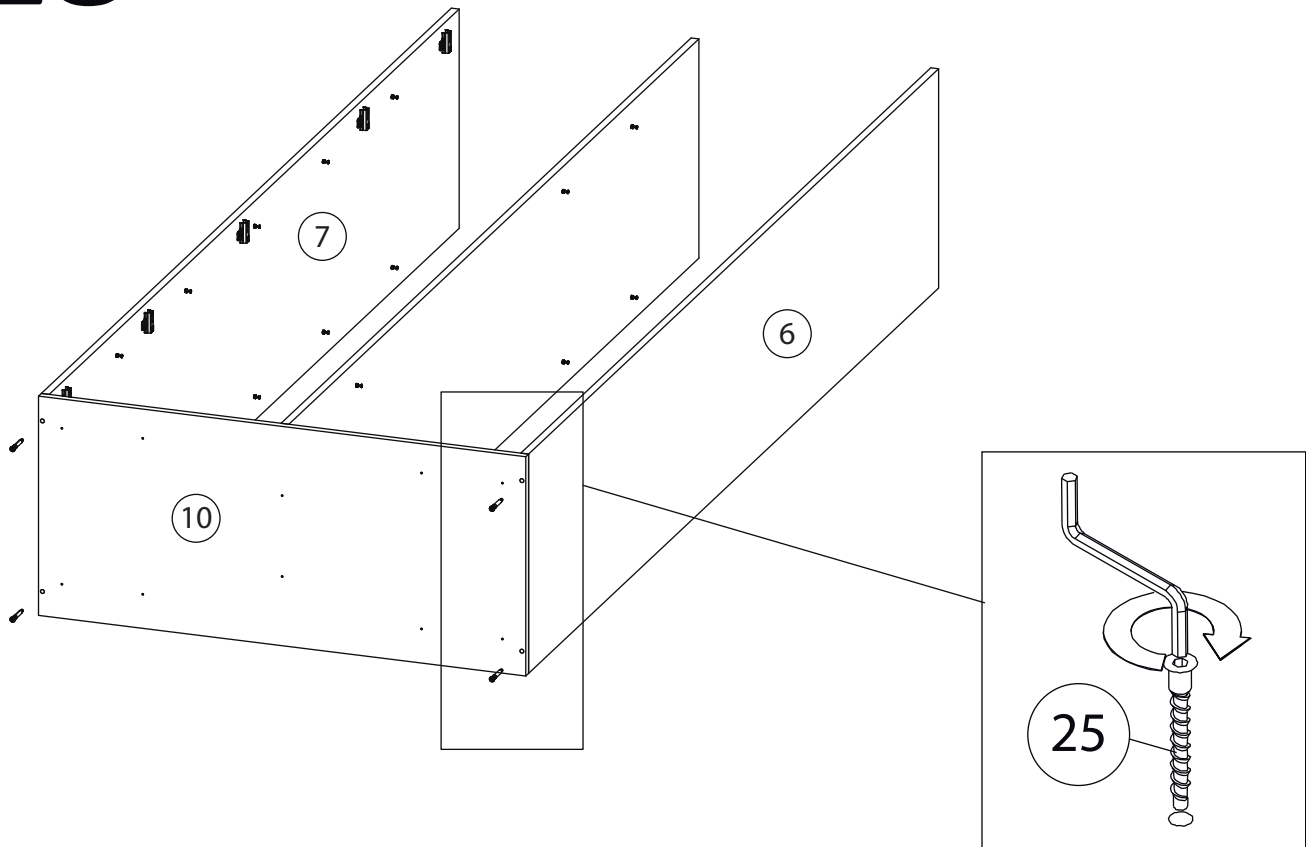

# 29

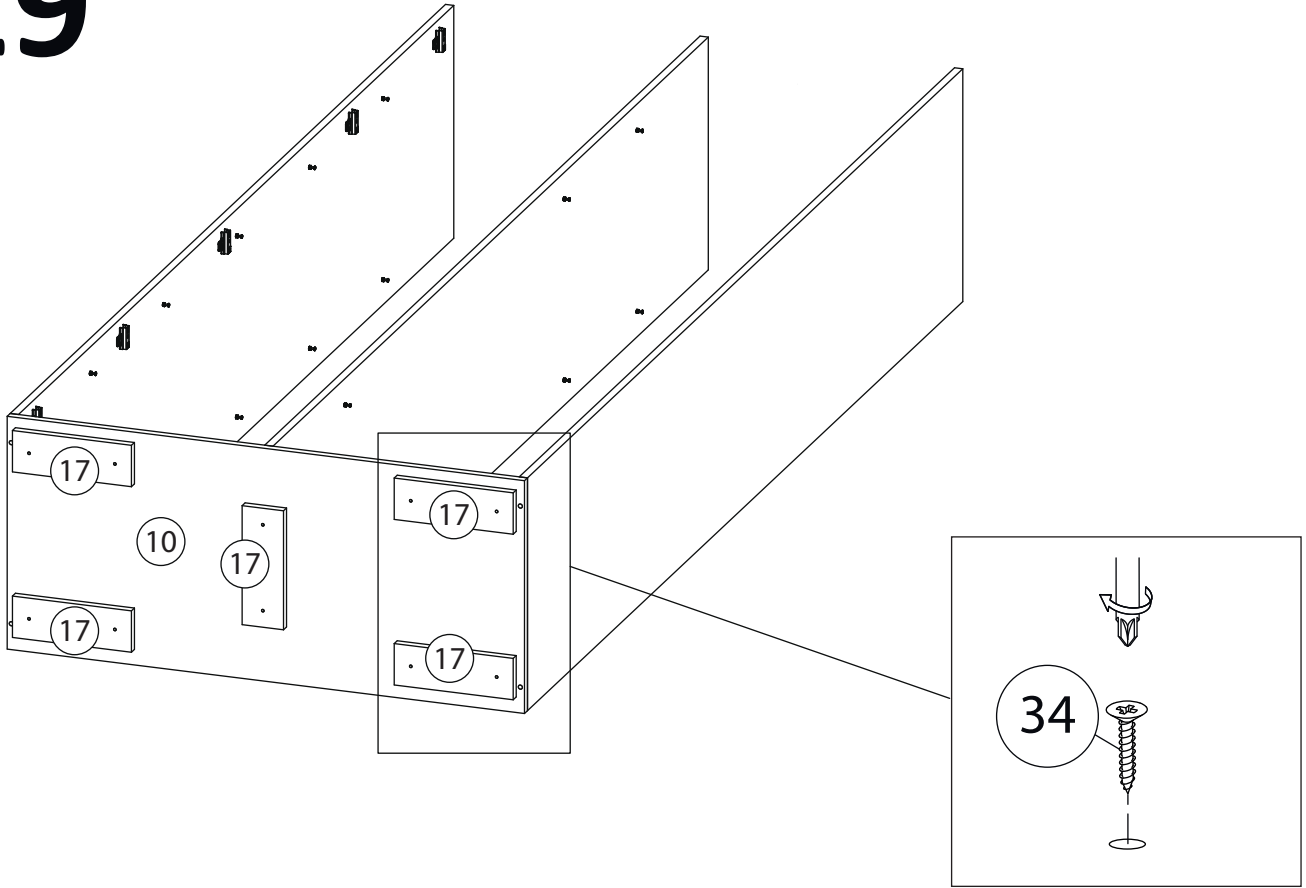

# 30

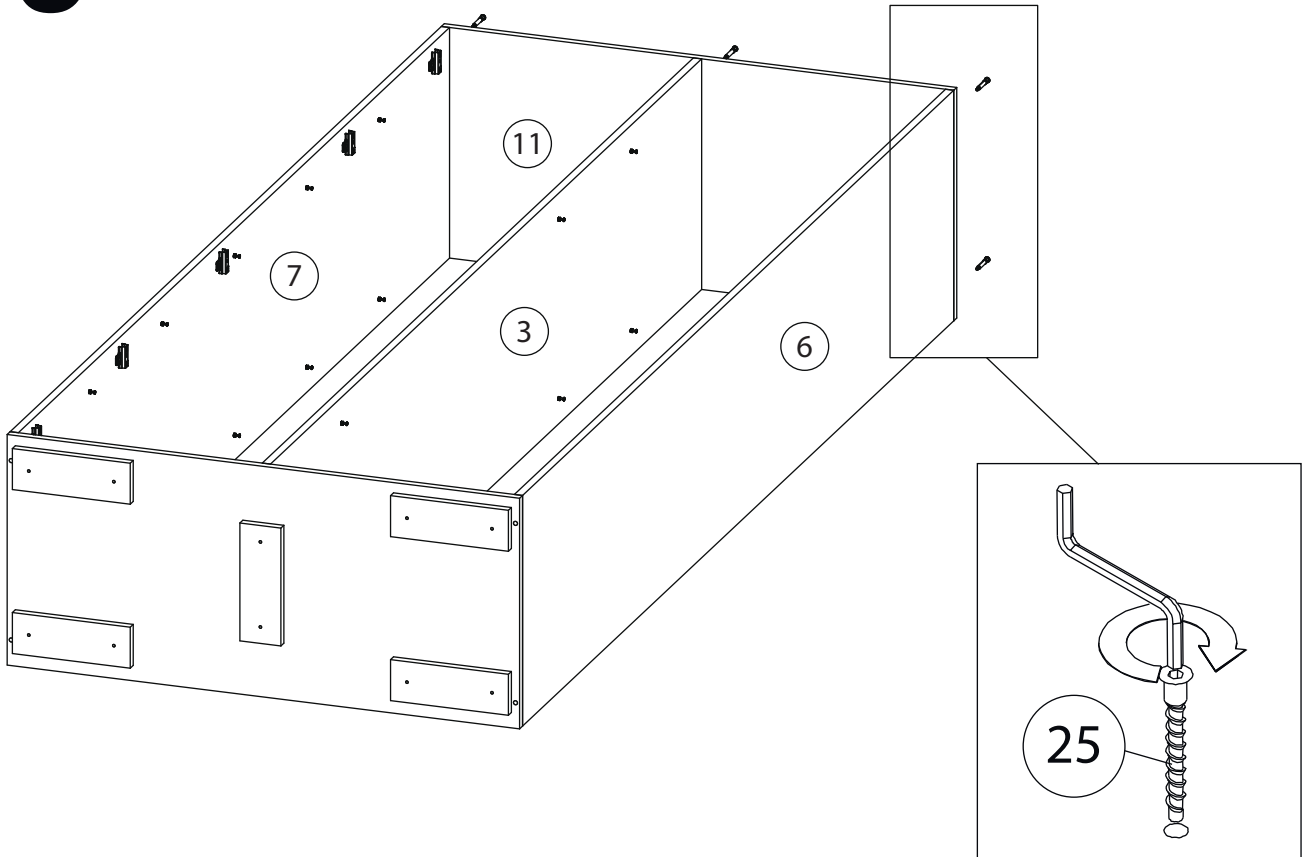

# 31

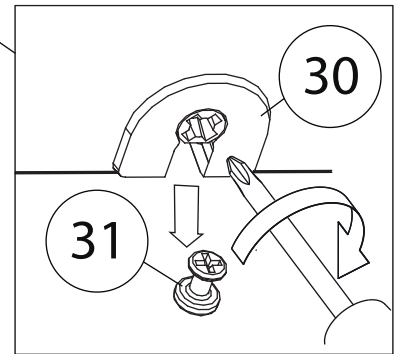
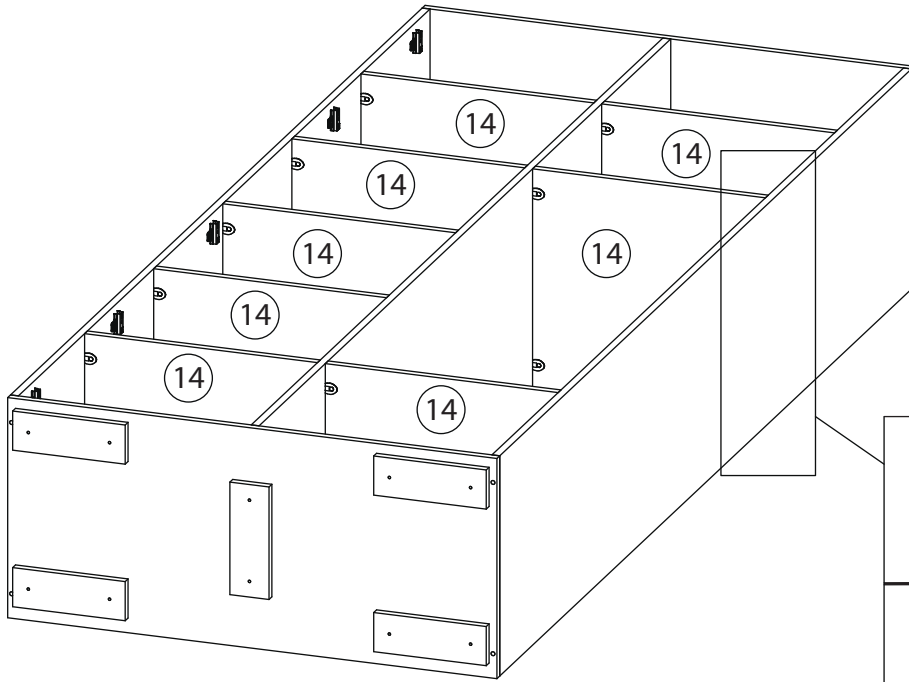

# 32

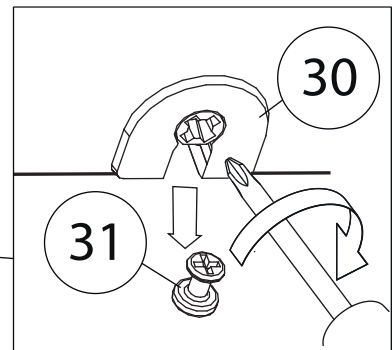
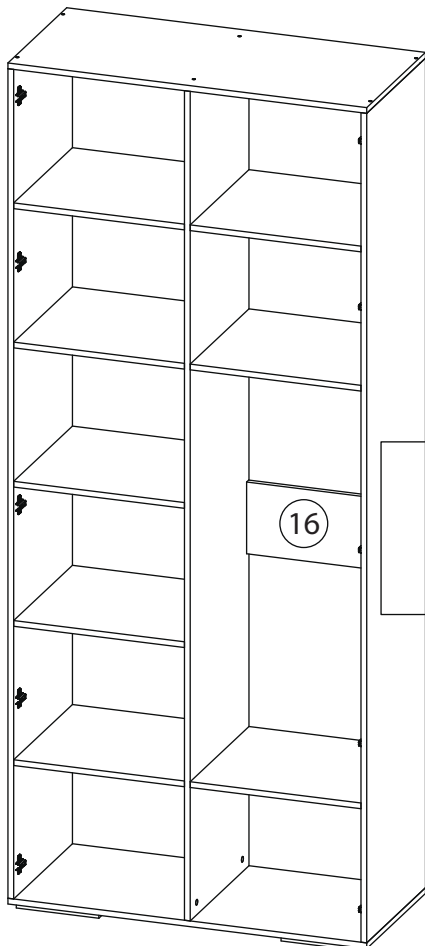

# 33

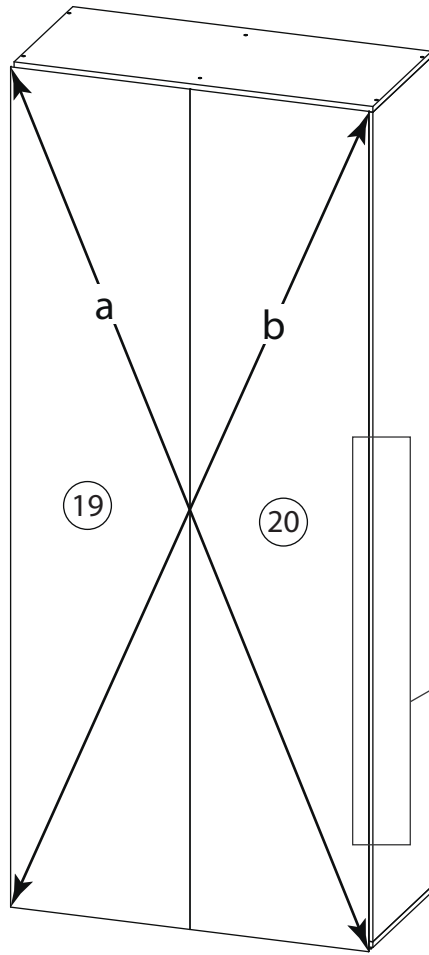

$$a=b$$

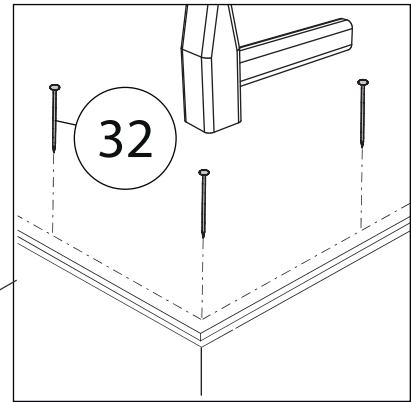

# 34

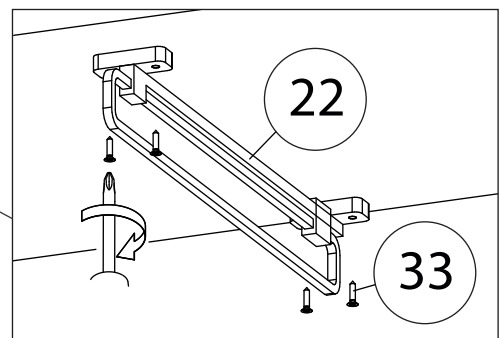
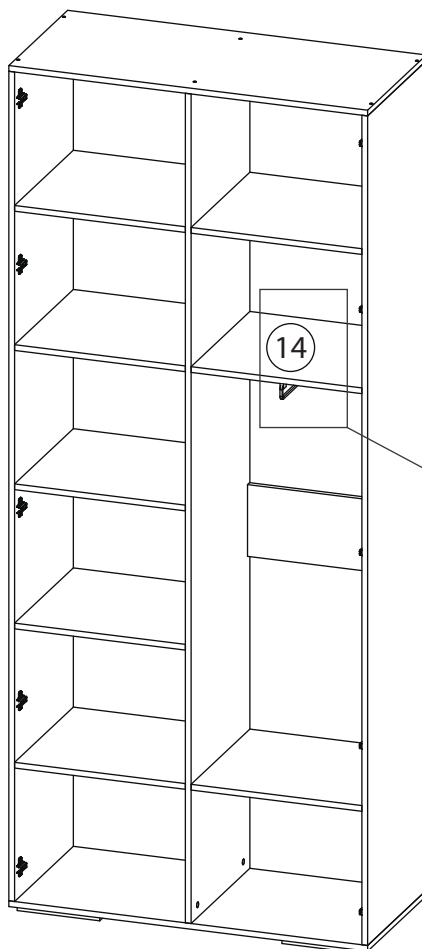

# 35

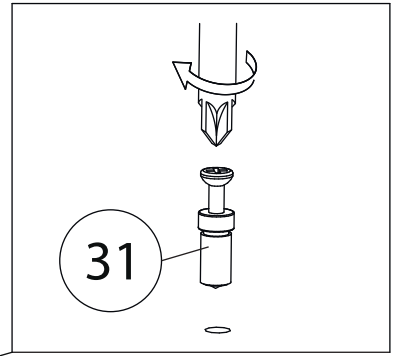
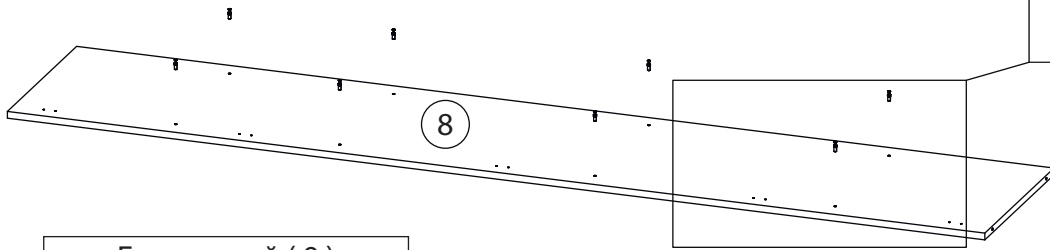

Бок правый (9)  
собирается зеркально

# 36

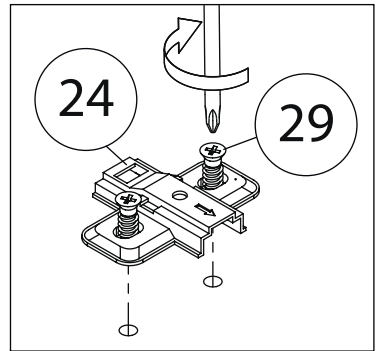
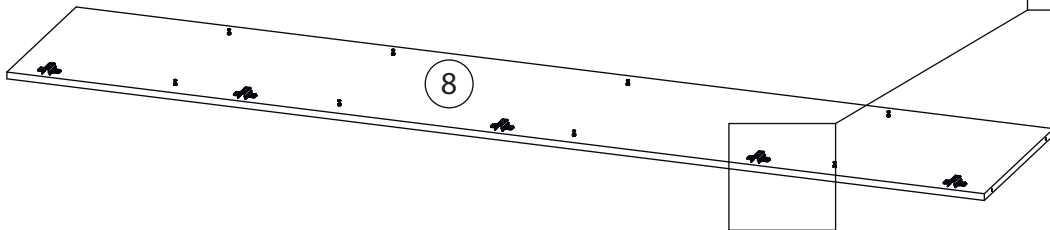

# 37

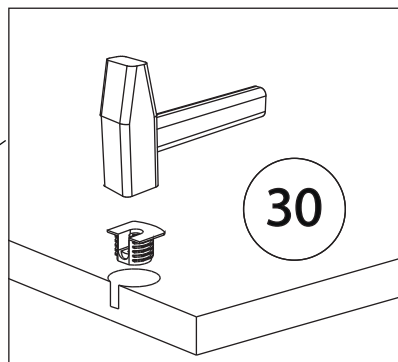
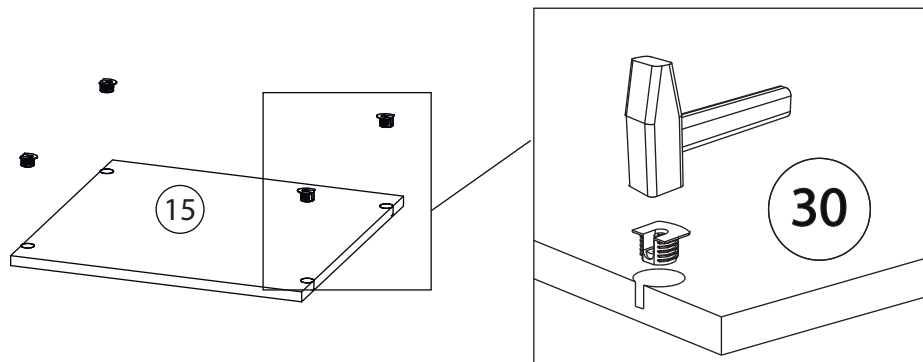

# 38

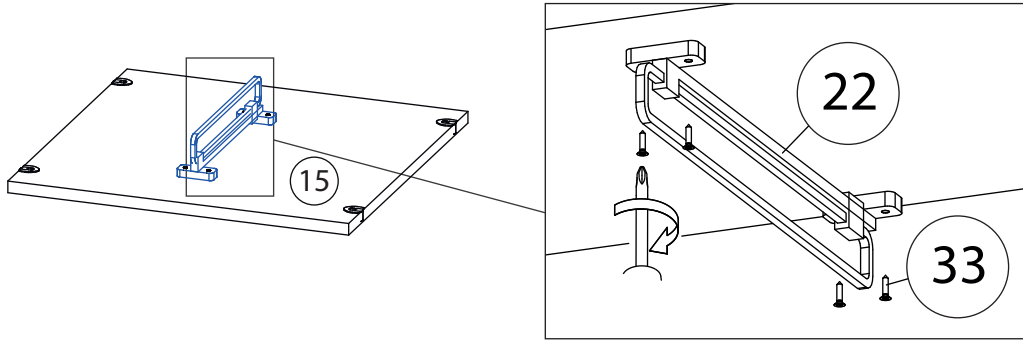

# 39

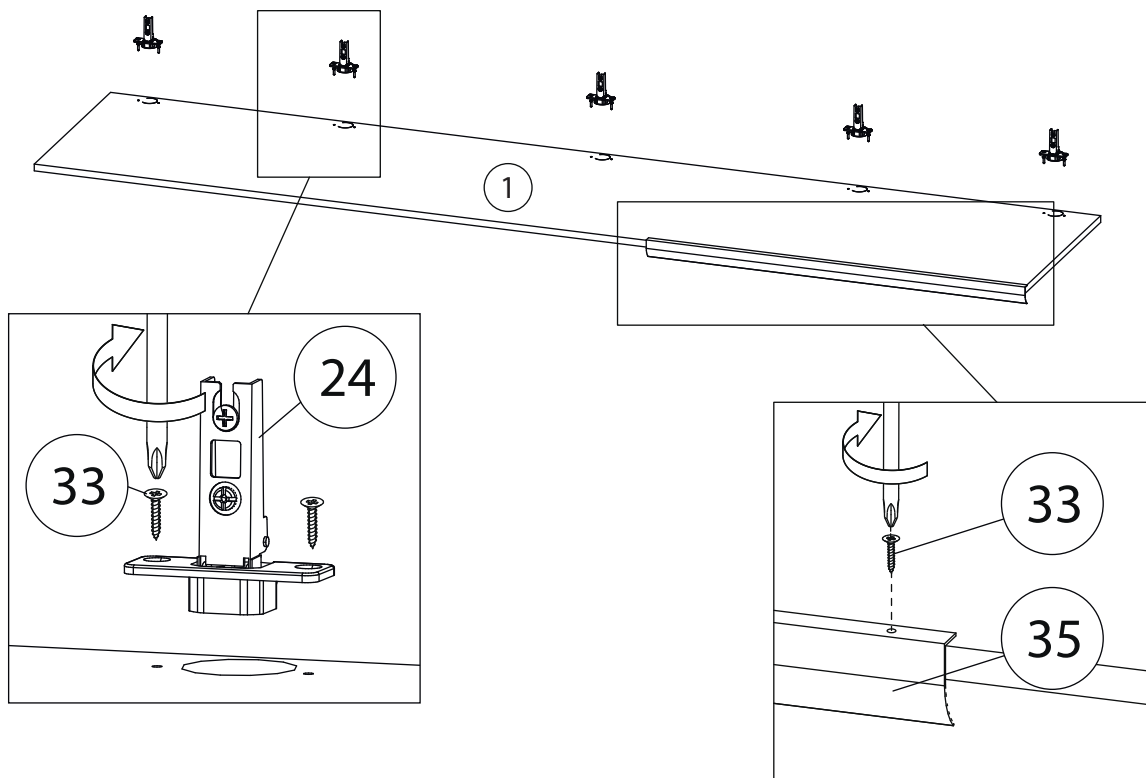

# 40

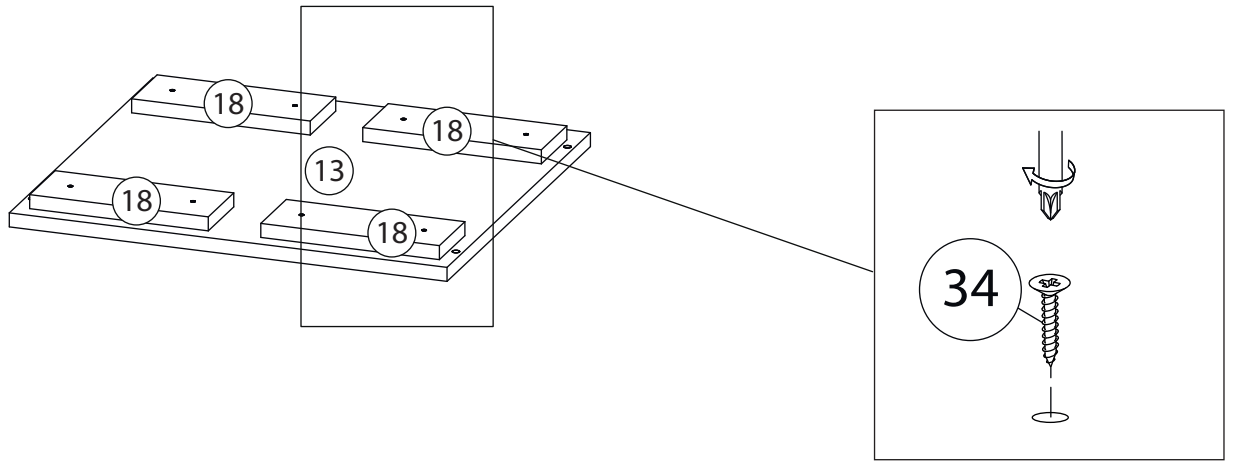

# 41

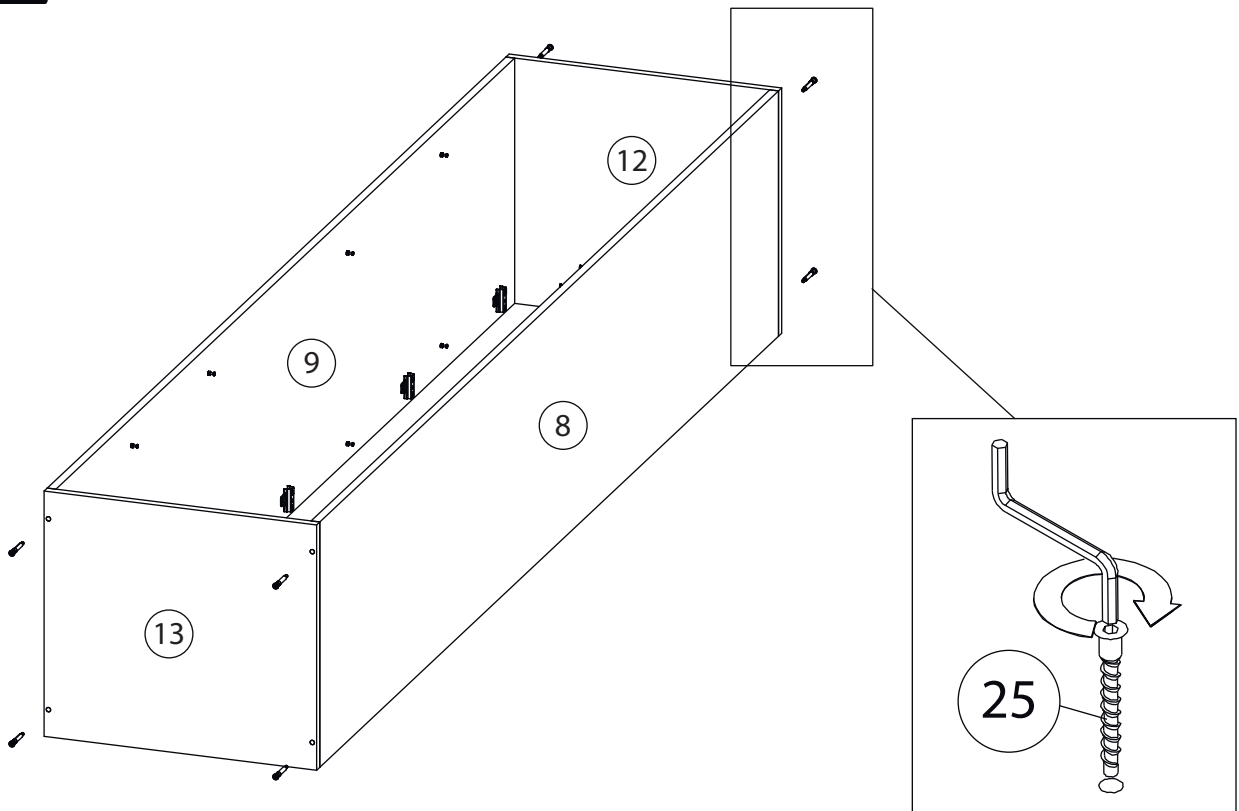

# 42

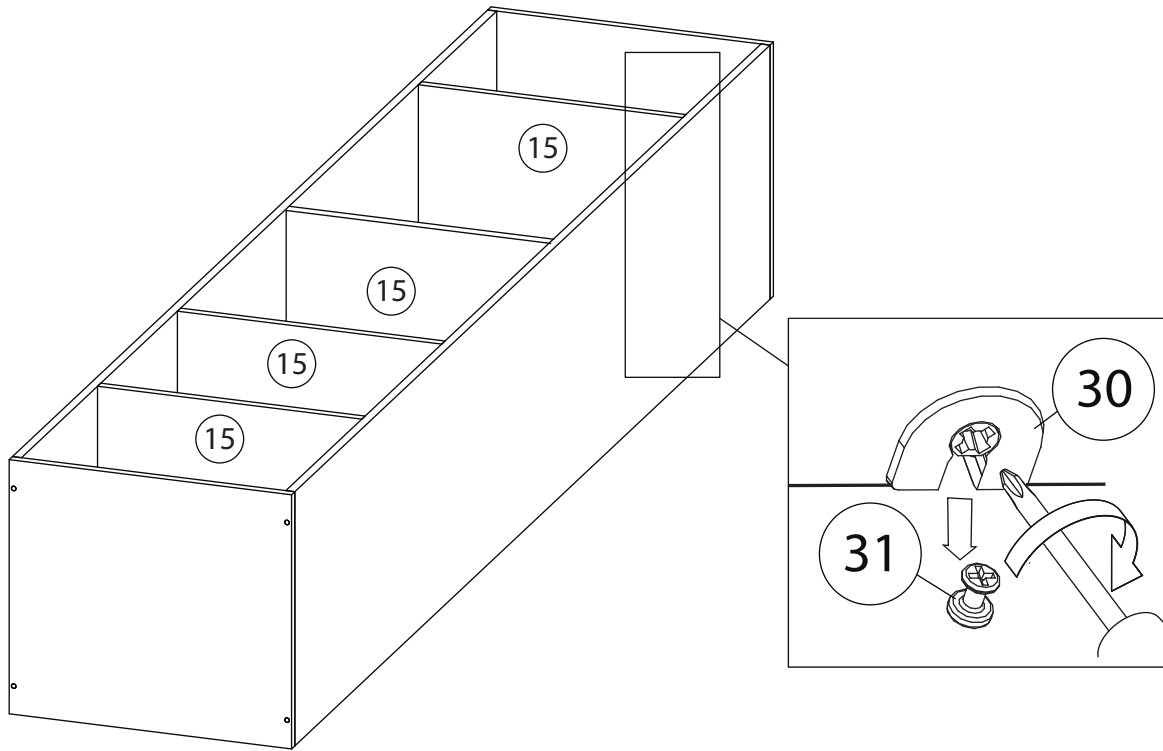

# 43

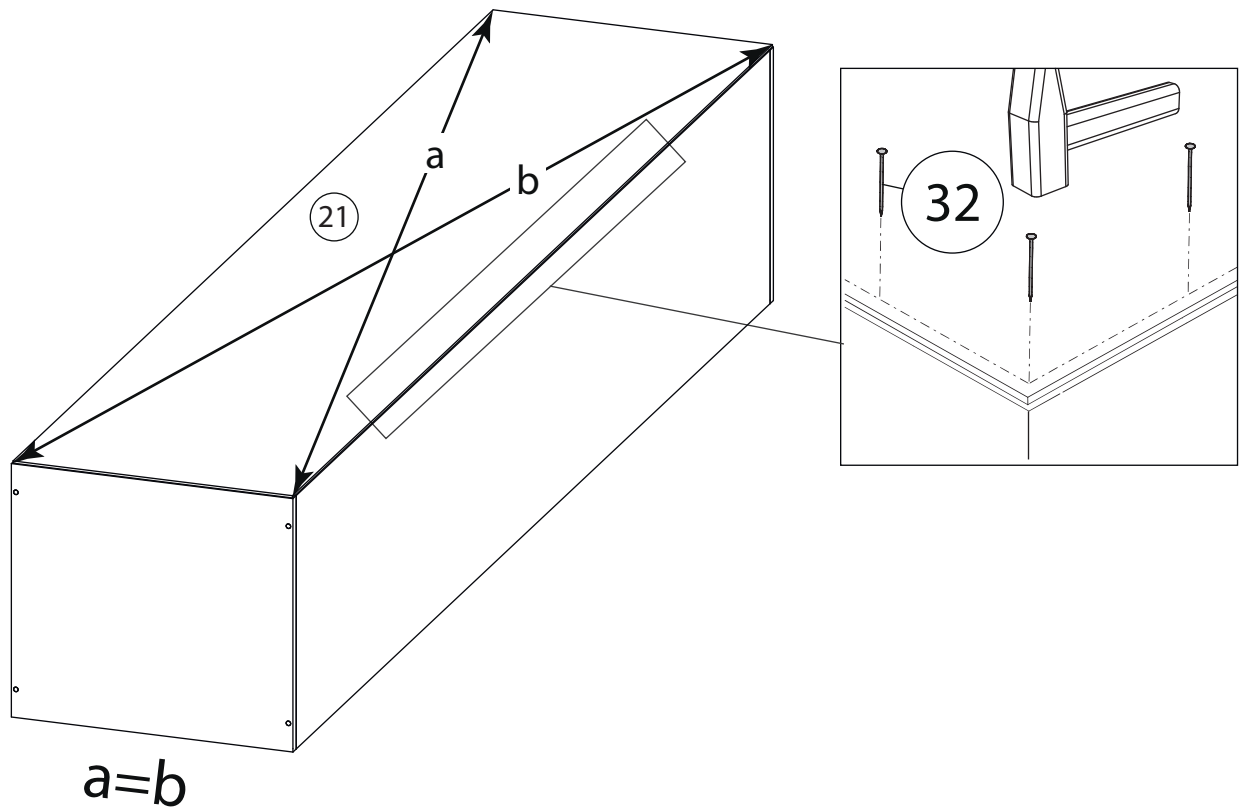

# 44

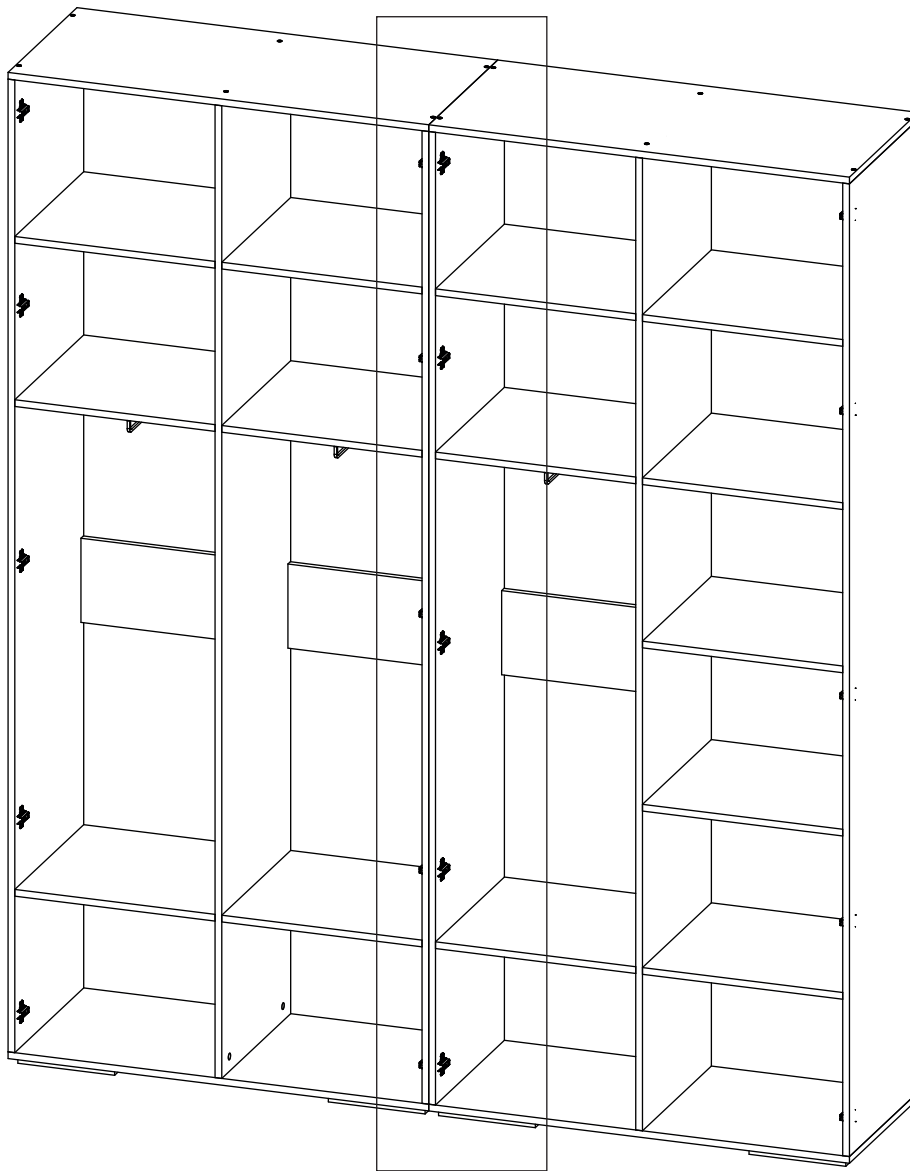

Два модуля стягиваются между собой межсекционными стяжками ( 33 ).  
Предварительно в соприкасающихся боковинах просверливаются сквозные отверстия диаметром 5мм, в произвольном месте, под стяжки

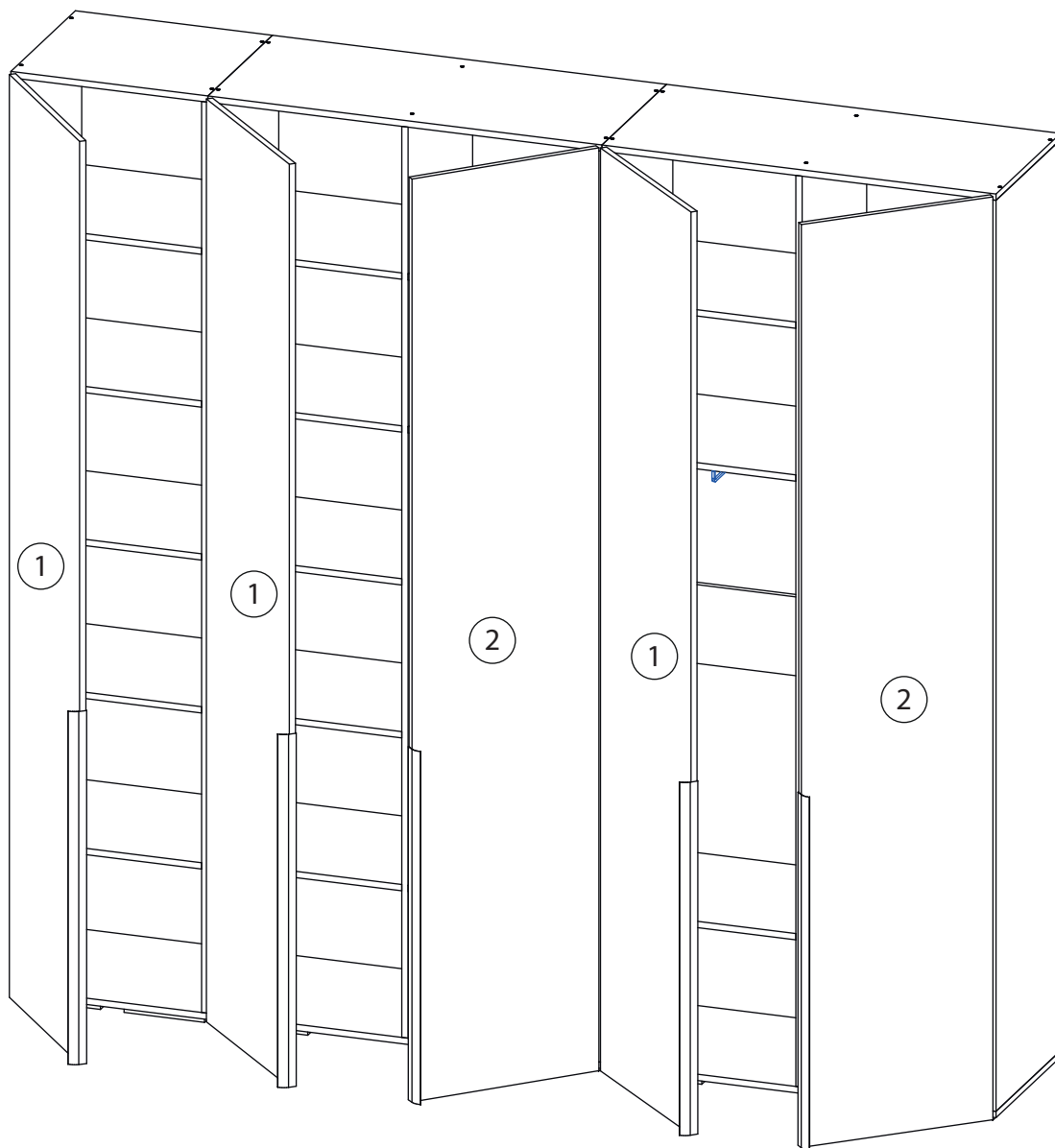
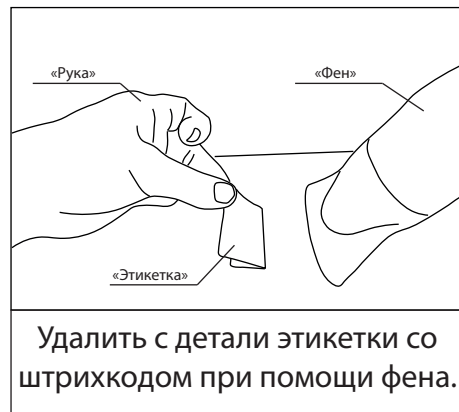

Заклеить технические отверстия заглушками.

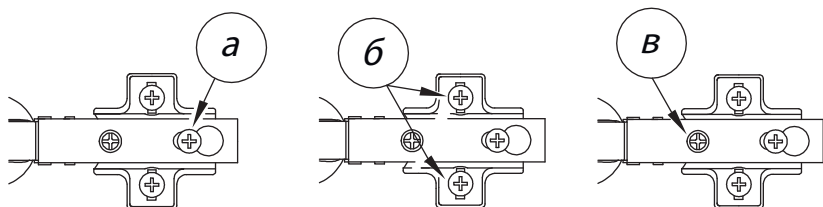

### Регулировка петель

а - регулировка расстояния между дверью и корпусом  
 б - регулировка положения двери по-вертикали  
 в - регулировка положения ТТдвери по-горизонтали