

# Инструкция по сборке

Мори

Шкаф угловой - 10

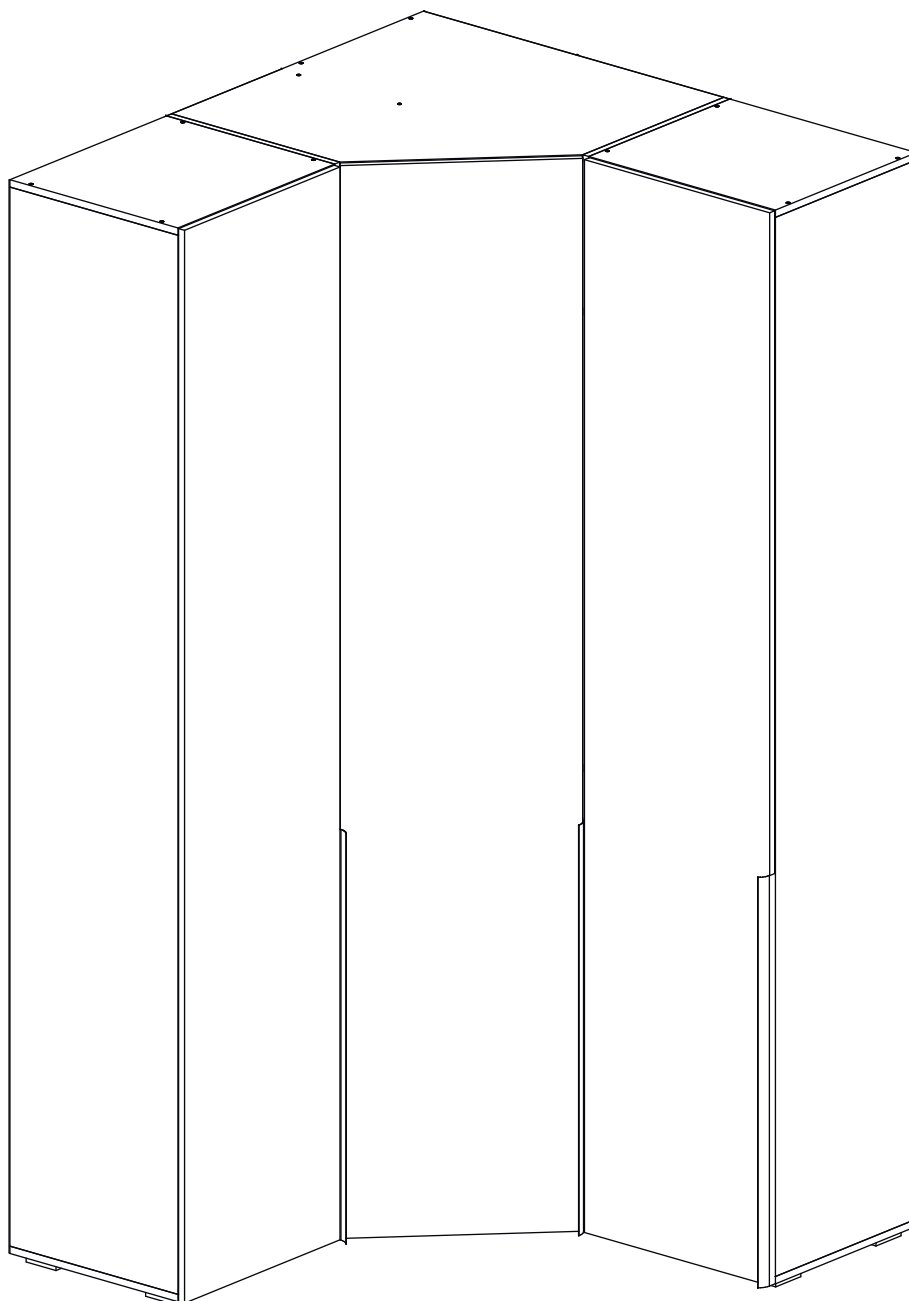





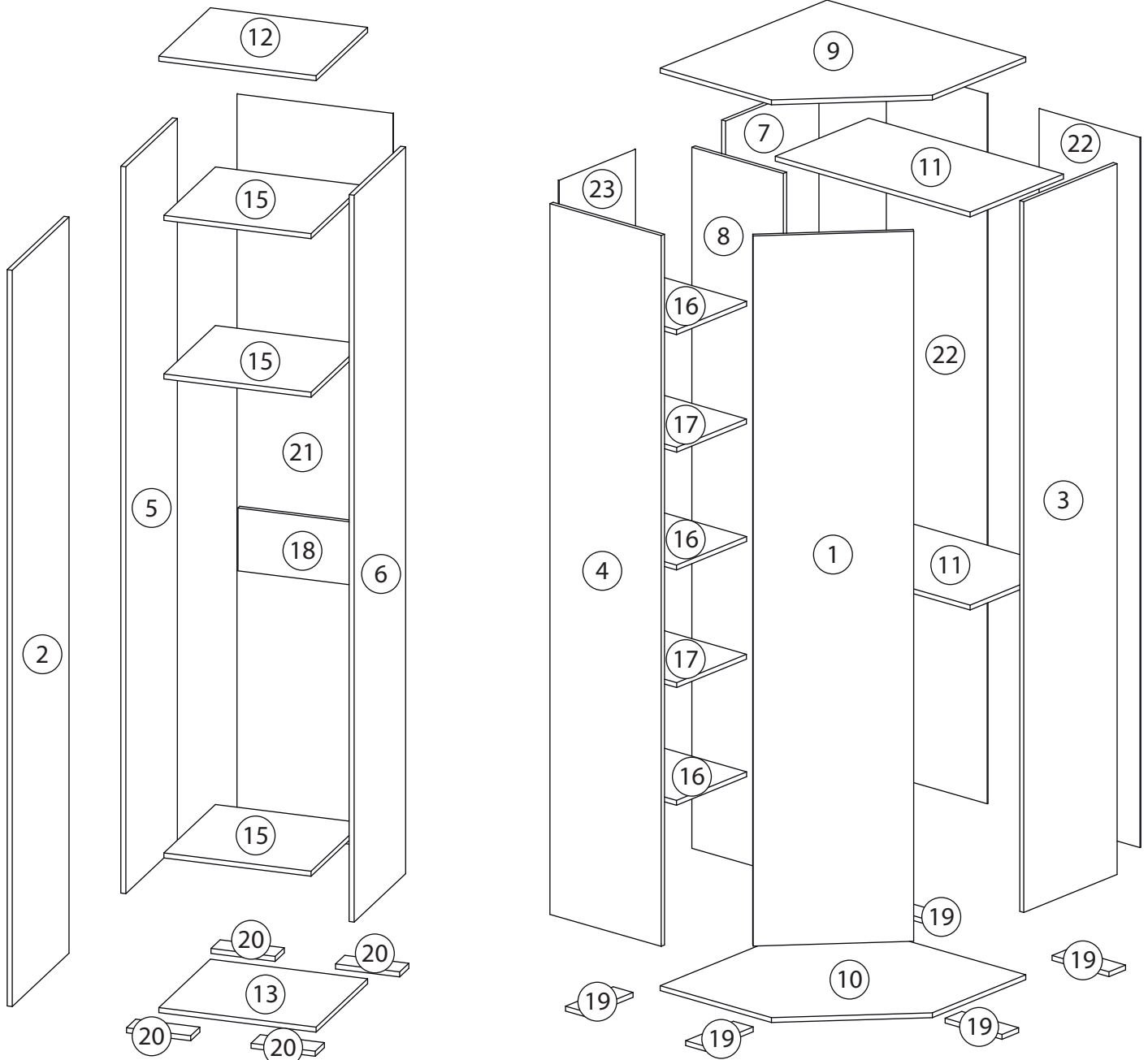

# Детали

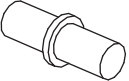
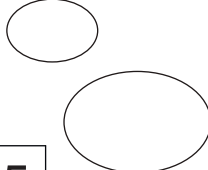
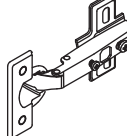
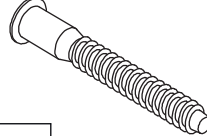
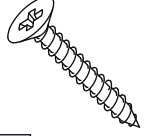
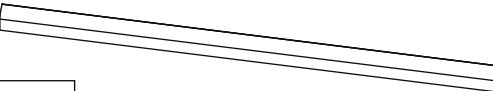
Поз.	Наименование	Кол-во	Длина	Ширина	Поз.	Наименование	Кол-во	Длина	Ширина
1	Фасад	1	2342	499,2	13	Горизонтальная	1	500	450
2	Дверь	2	2342	496	14	Горизонтальная	1	500	450
3	Бок	1	2344	450	15	Полка	6	468	450
4	Бок	1	2344	450	16	Полка	3	338	370
5	Бок левый	2	2312	450	17	Полка	2	336	370
6	Бок правый	2	2312	450	18	Ребро жесткости	2	468	200
7	Задняя стенка	1	2312	450	19	Горизонтальная	5	230	80
8	Перегородка	1	2312	370	20	Горизонтальная	8	204	80
9	Крышка	1	804	804	21	Задняя стенка	2	2342	496
10	Дно	1	804	804	22	Задняя стенка	2	2342	408
11	Полка	2	788	450	23	Задняя стенка	1	2342	368
12	Крыша	2	500	450					

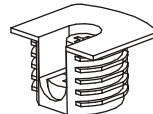
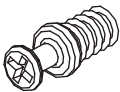
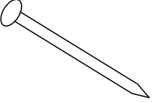

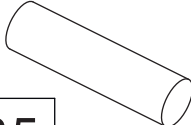
# Фурнитура

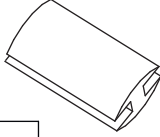
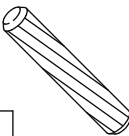
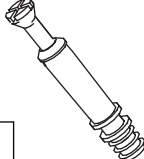
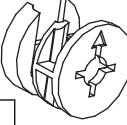
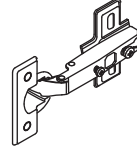
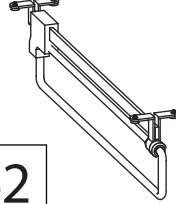
 24	 25	 26	 27	 28
<u>Полкодержатель</u>	<u>Заглушка</u> $\varnothing 13-20$	<u>Петля 45 градусов</u>	<u>Евровинт 7x50</u>	<u>Саморез 3,5x30</u>
 29	 30	 31	 32	
<u>Ручка</u>		<u>Евровинт 6,3x13</u>	<u>Стяжка VB35</u>	<u>Винт для стяжки</u> <u>VB35</u>
 33	 34	 35	 36	 37
<u>Гвоздь 1,6x25</u>	<u>Саморез 3,5x16</u>	<u>Штанга</u>	<u>Штангодержатель</u>	<u>Профиль для ДВП</u>
 38	 39	 40	 41	 42
<u>Шкант бук</u>	<u>Шток эксцентрика</u>	<u>Эксцентрик</u>	<u>Петля накладная</u>	<u>Штанга</u> <u>выдвижная</u>

# 1

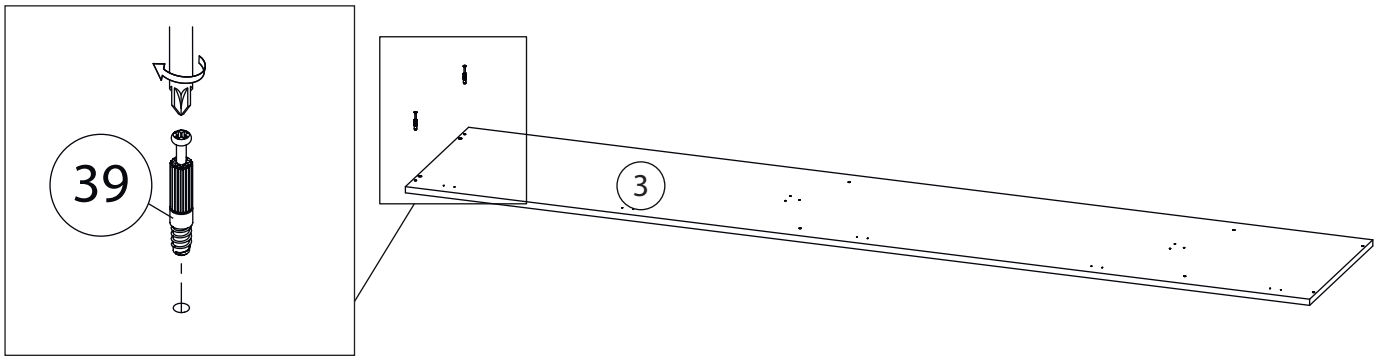

# 2

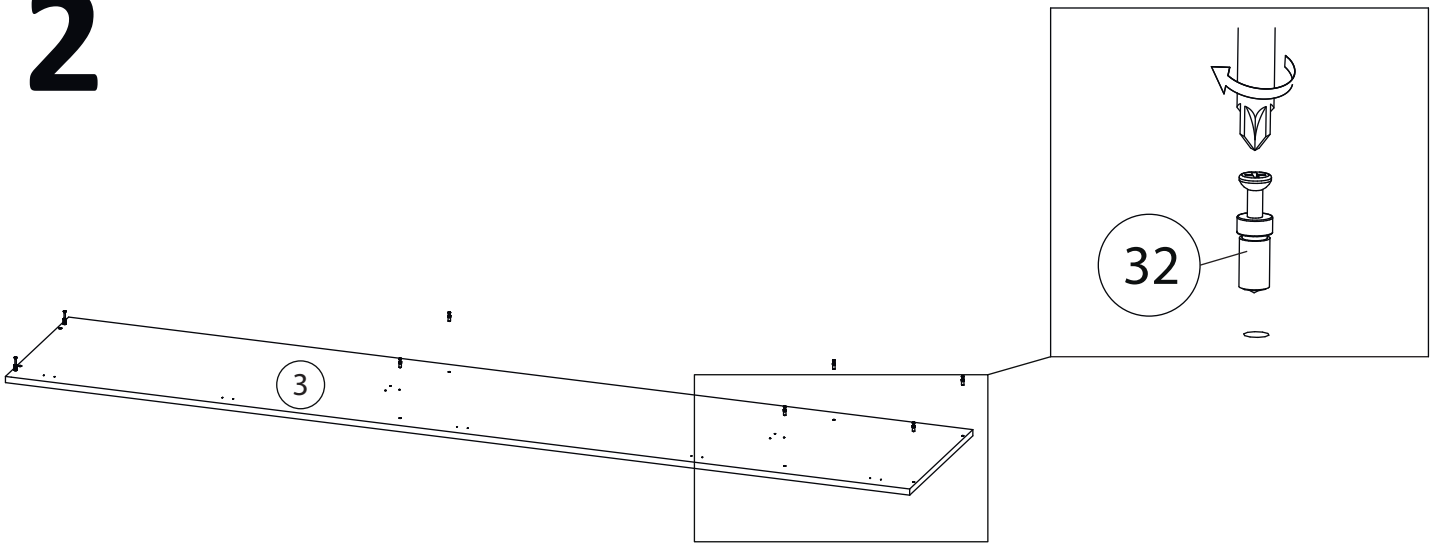

# 3

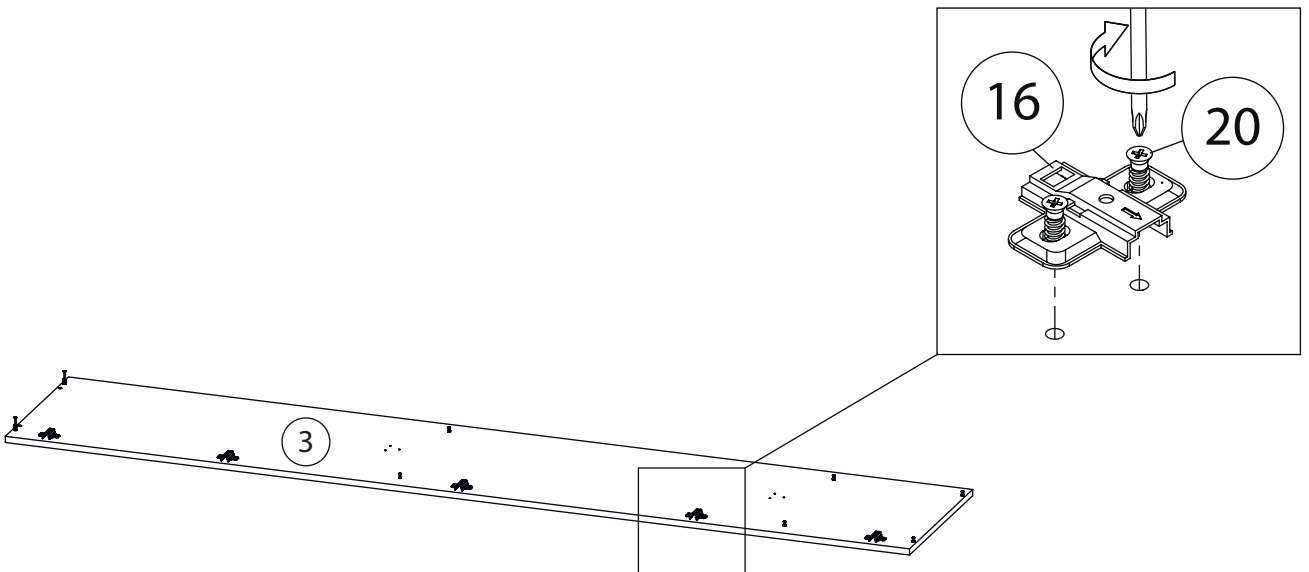

# 4

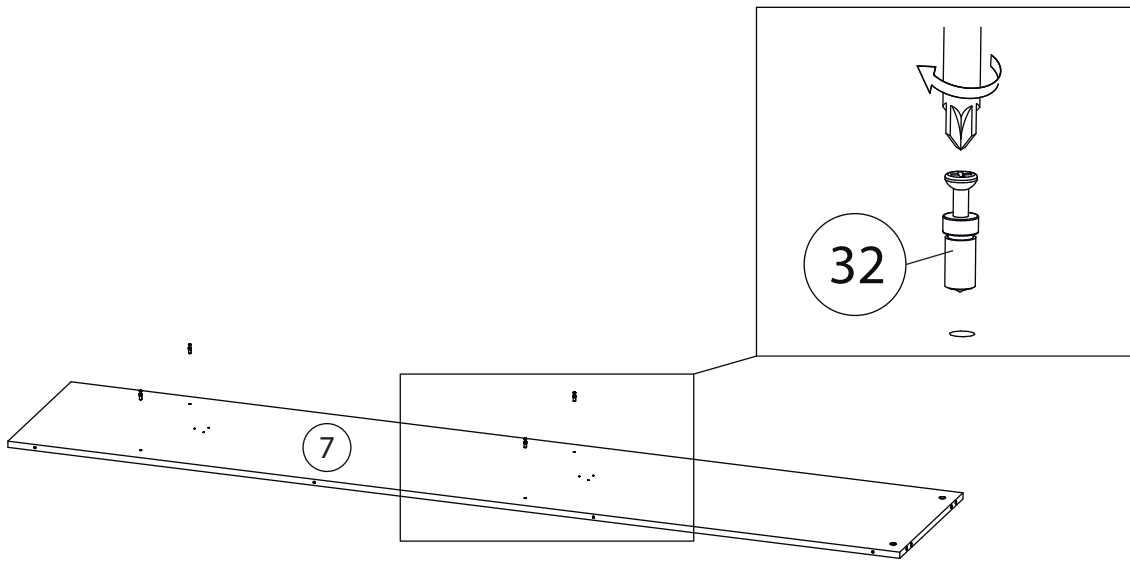

# 5

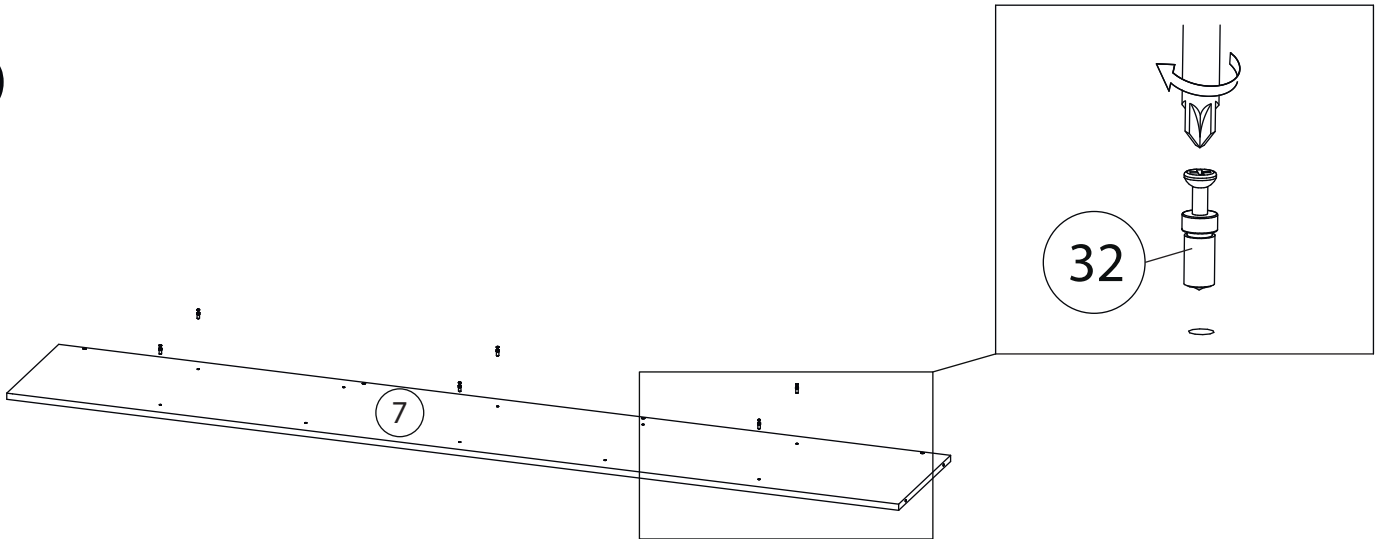

# 6

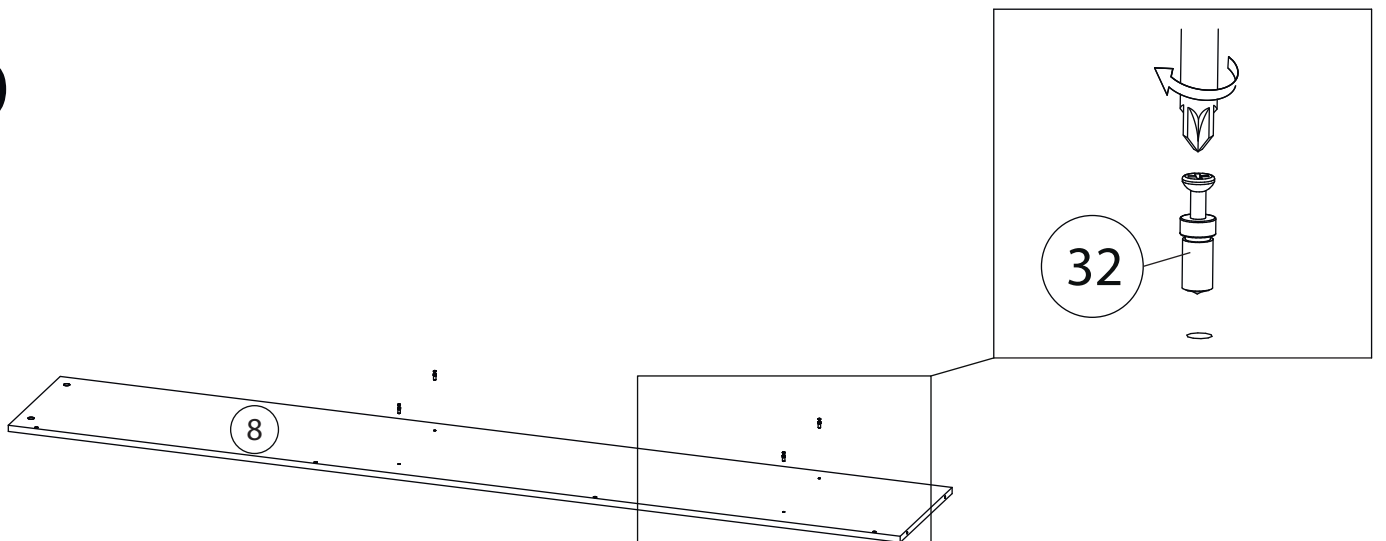

# 7

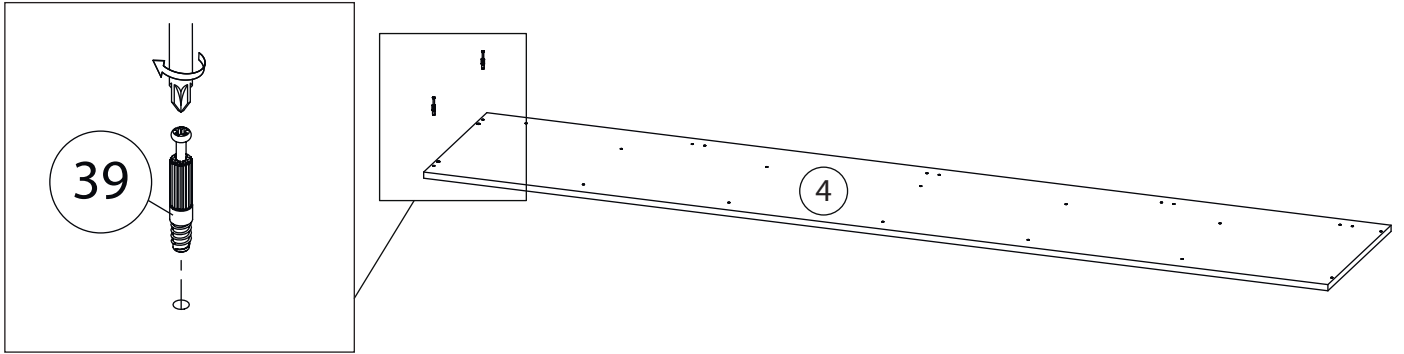

# 8

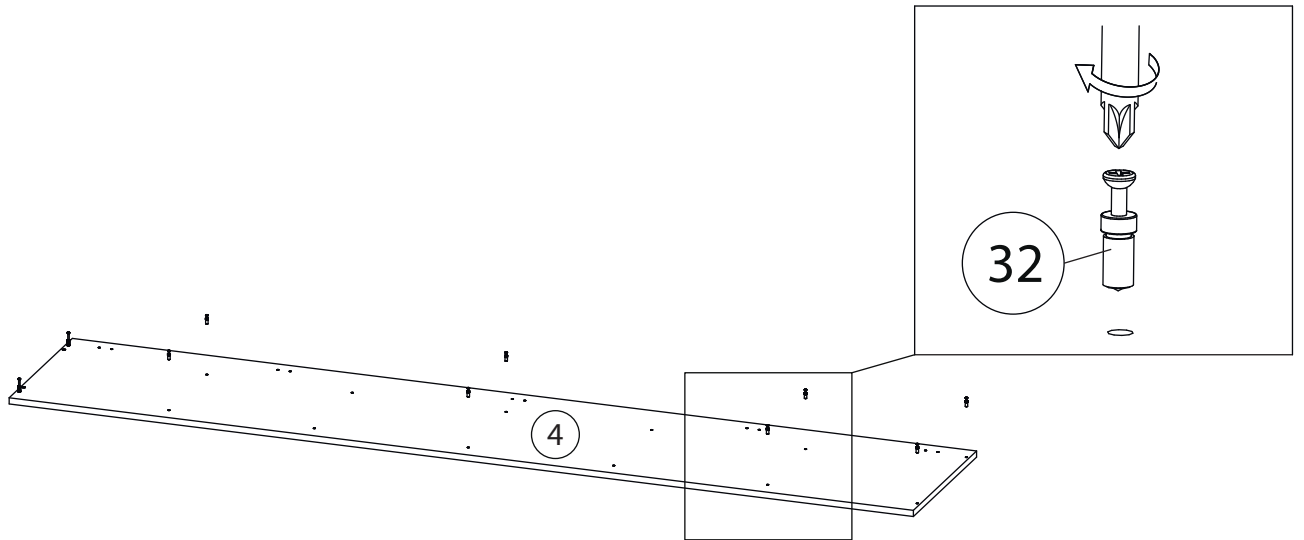

# 9

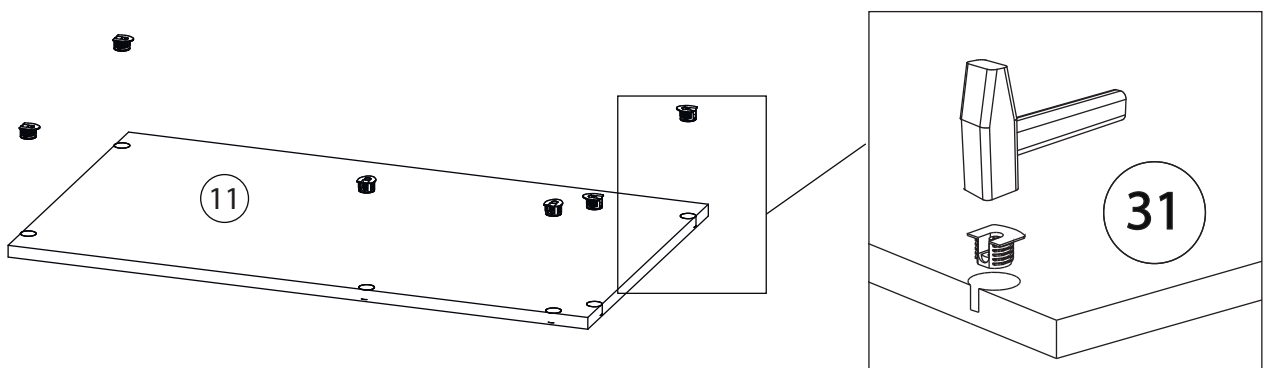

# 10

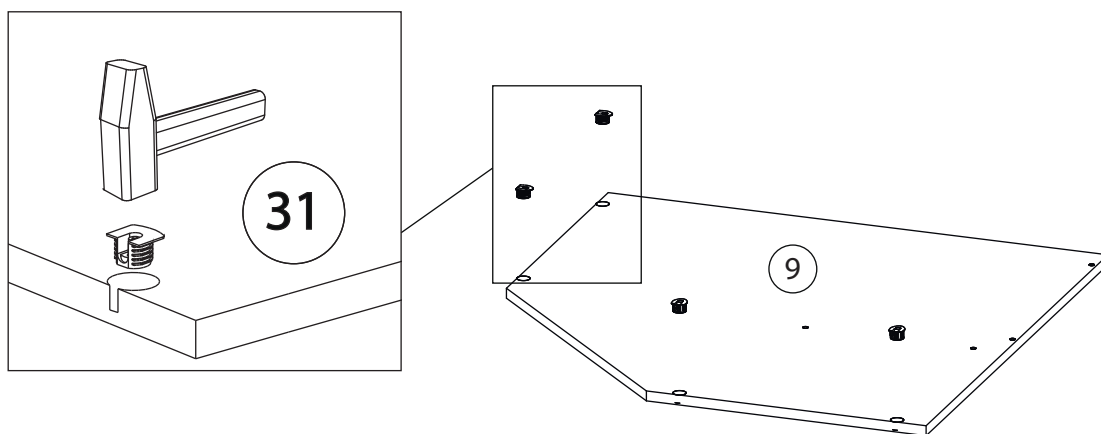

# 11

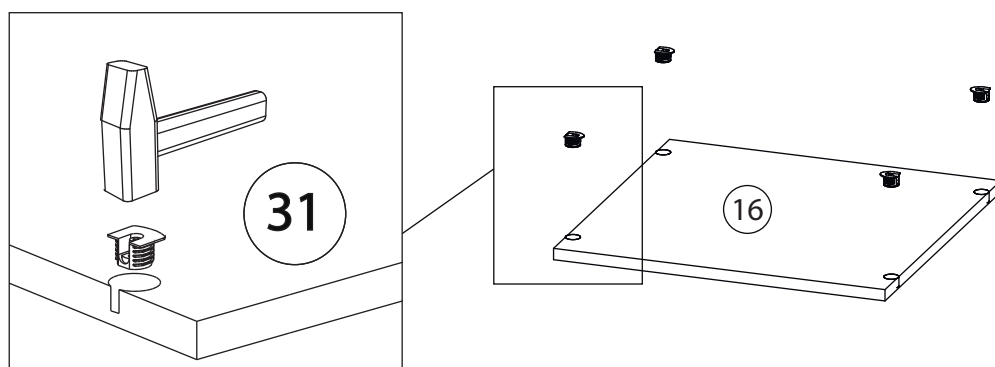

# 12

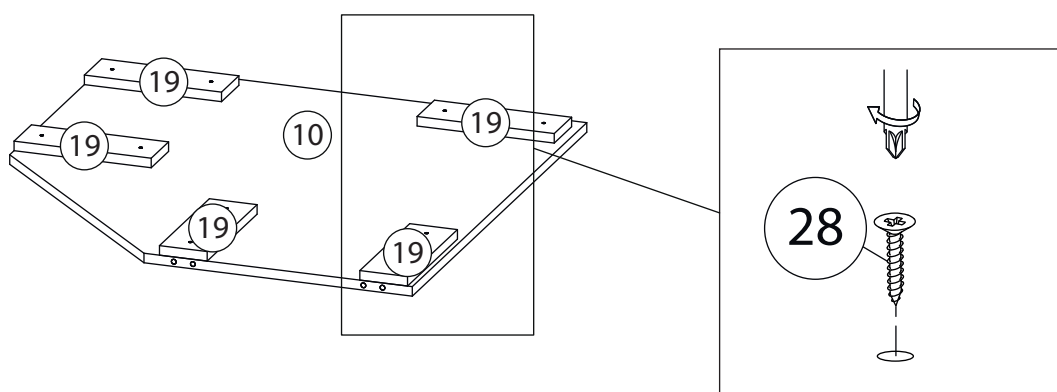

# 13

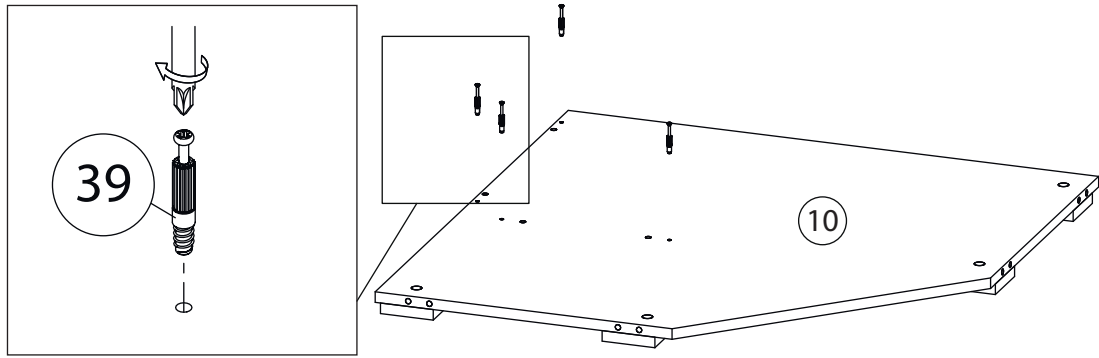

# 14

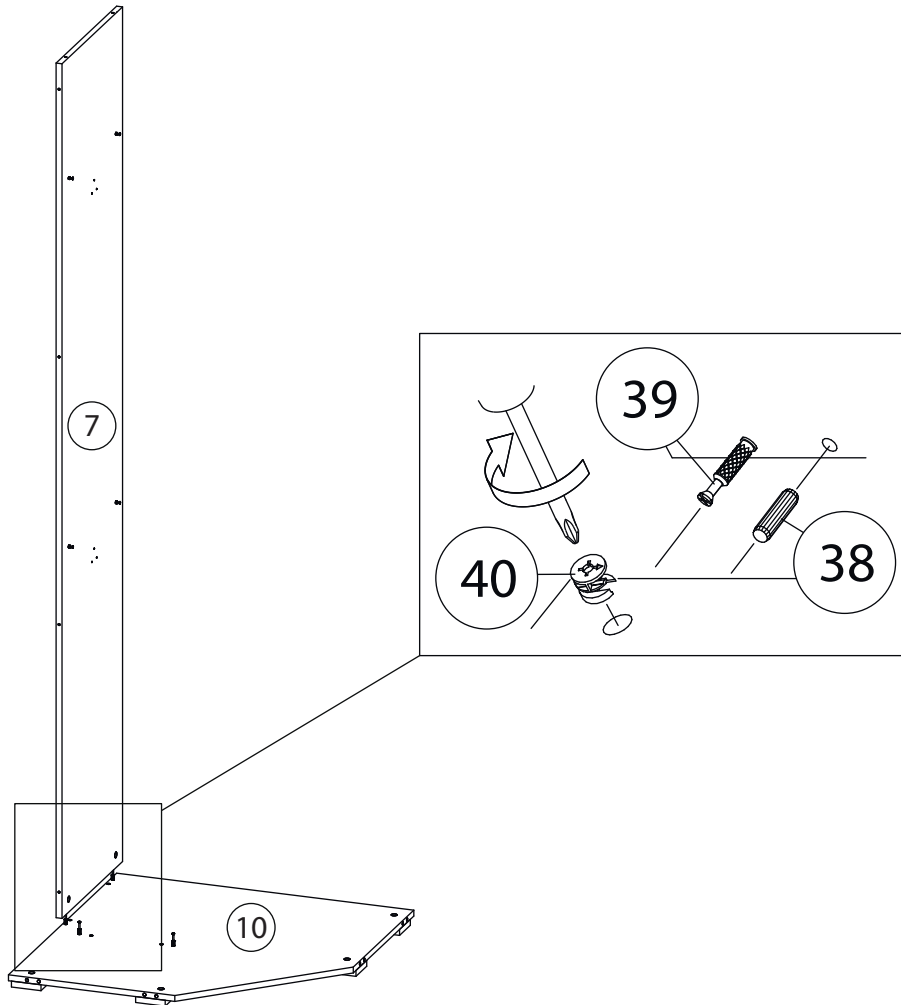

# 15

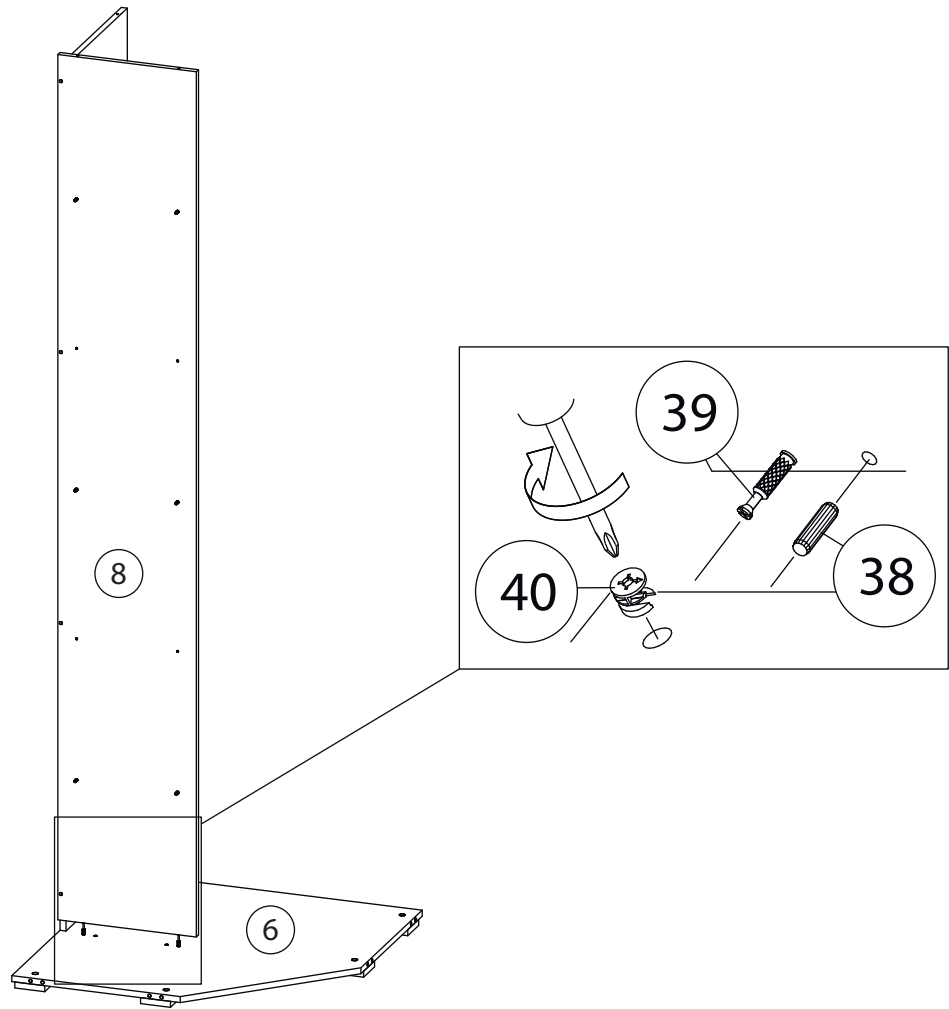

# 16

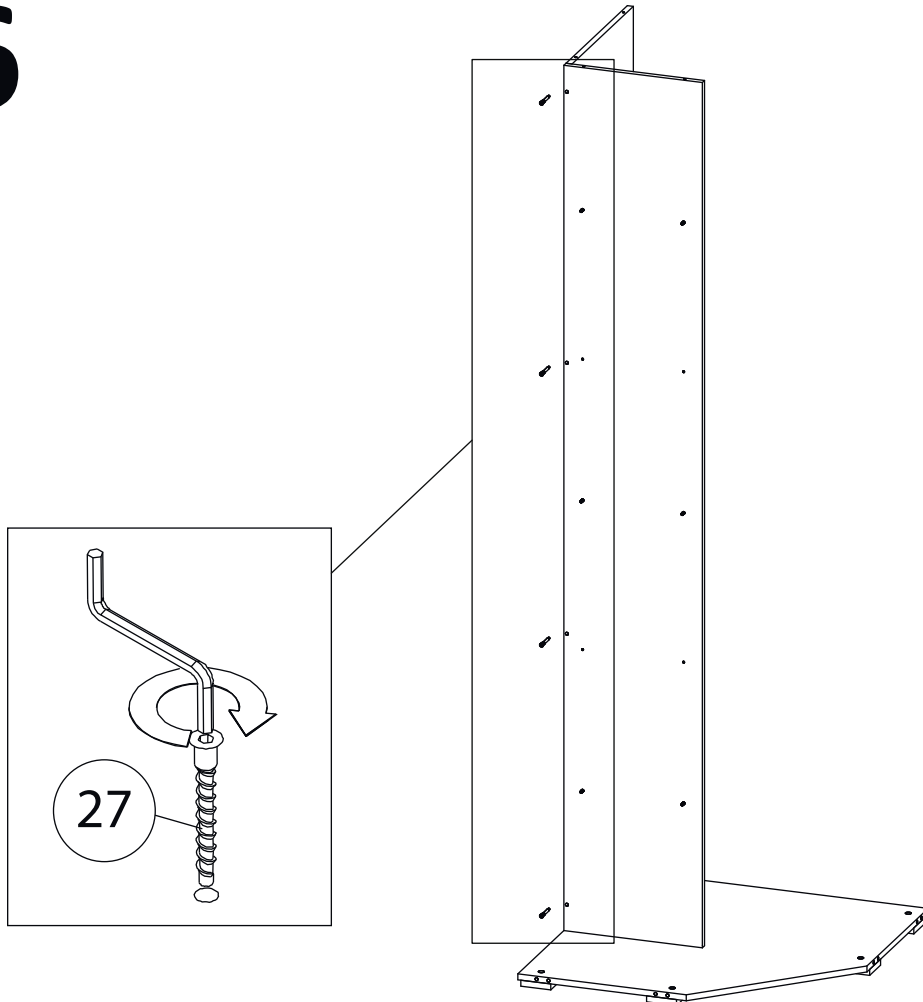

# 17

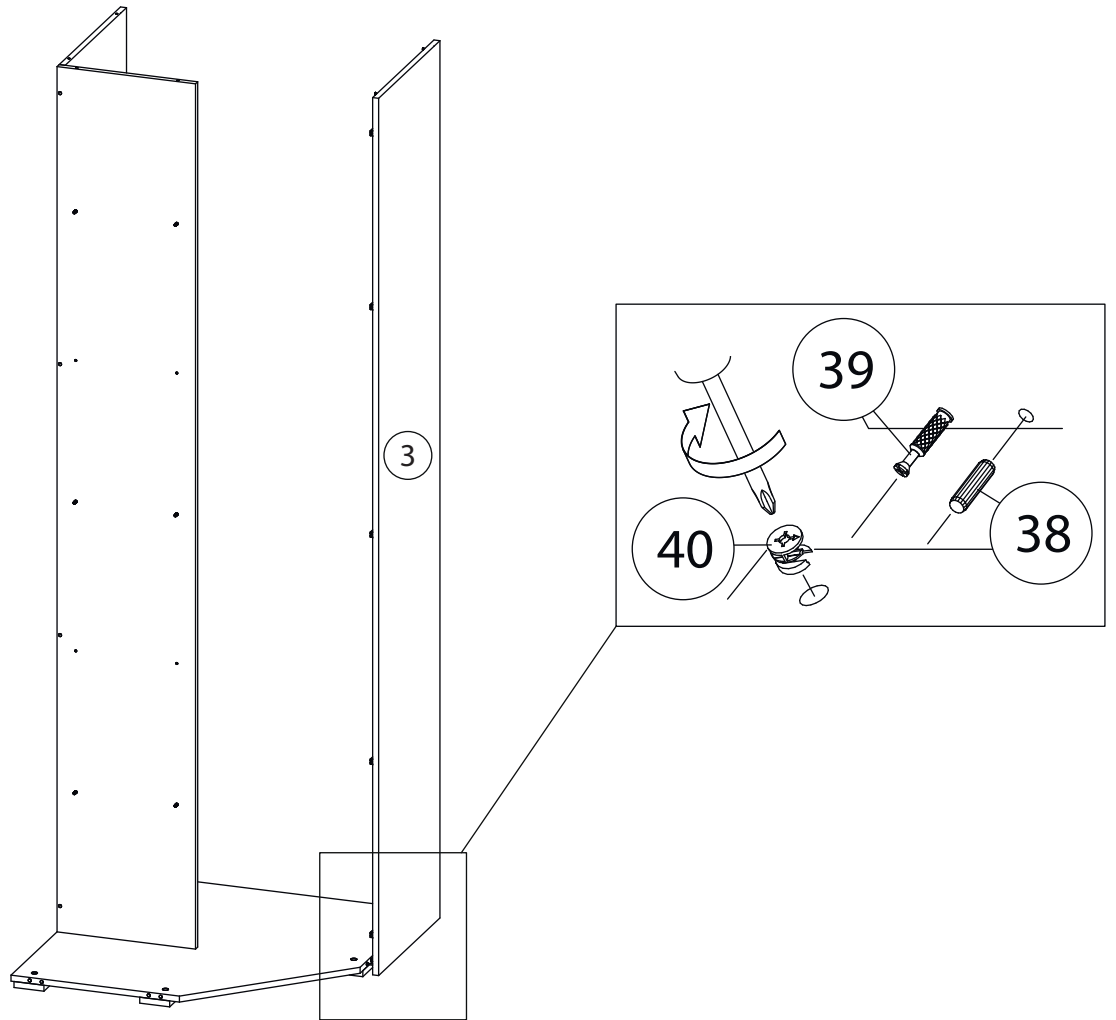

# 18

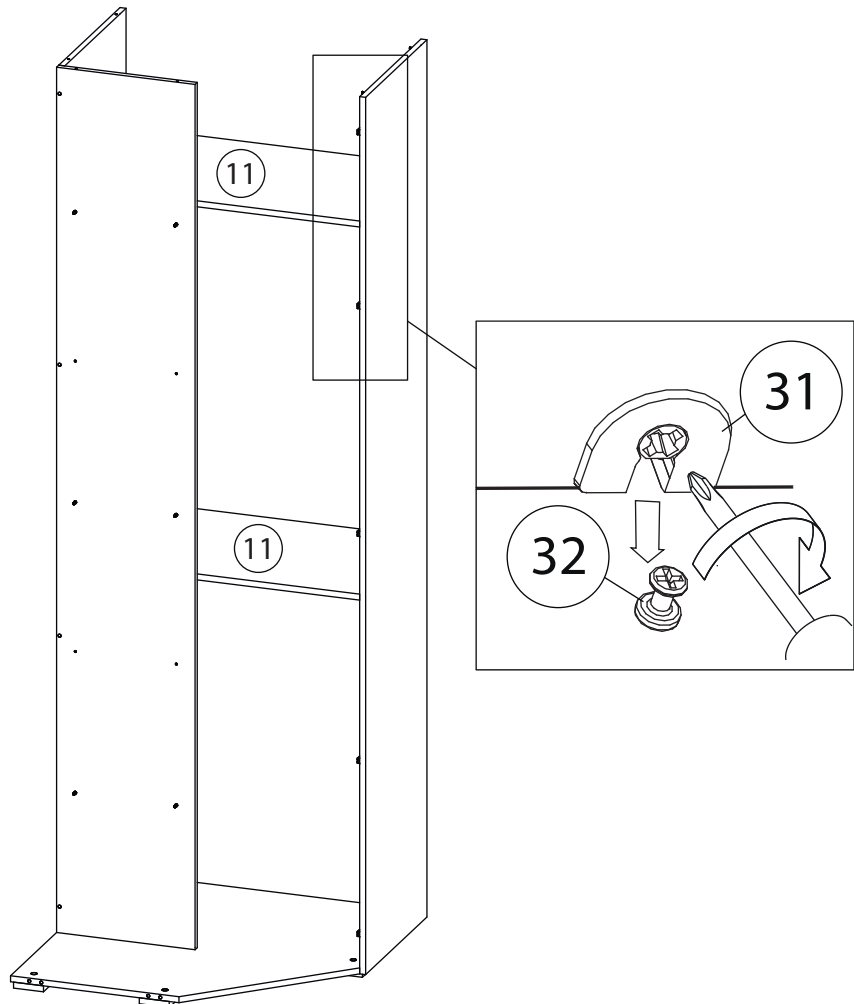

# 19

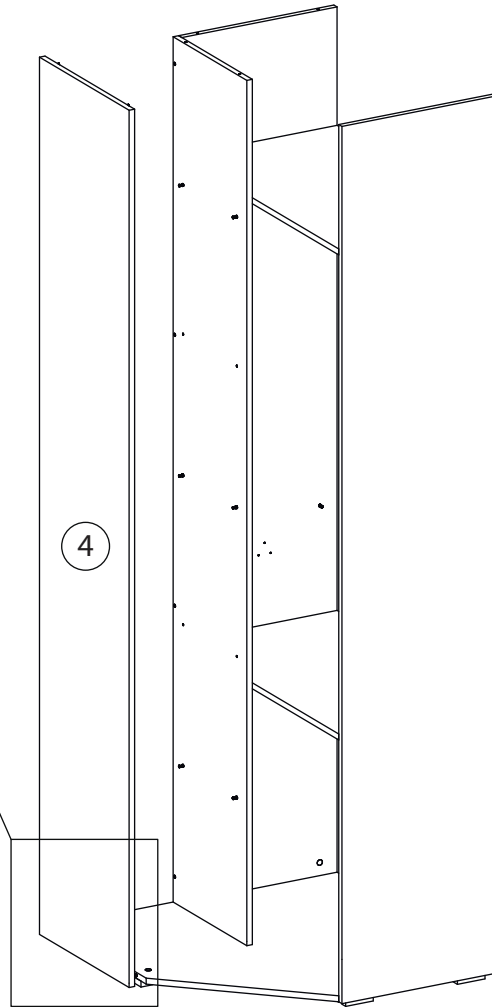
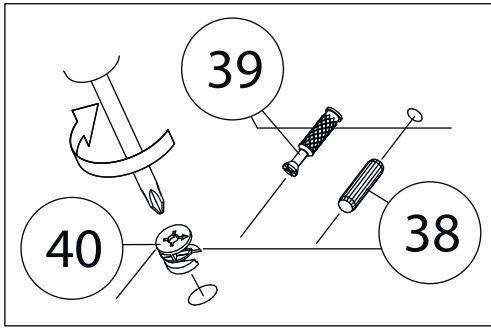

# 20

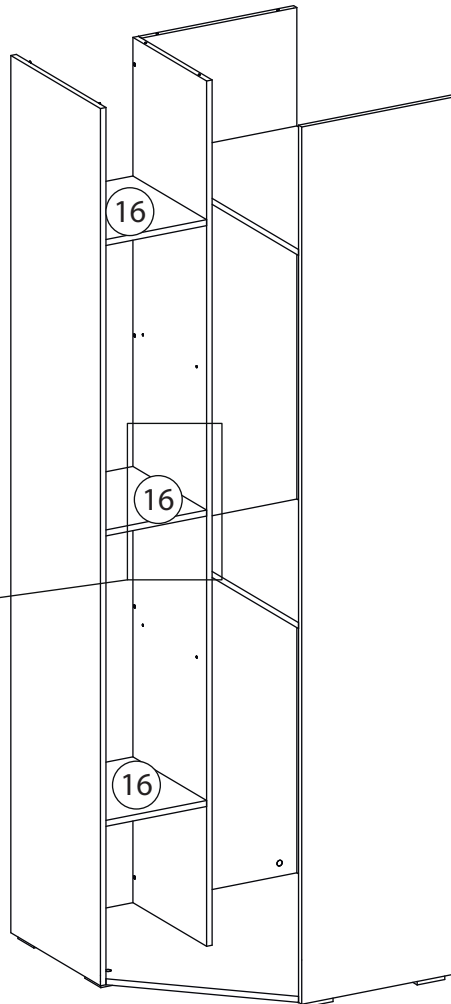
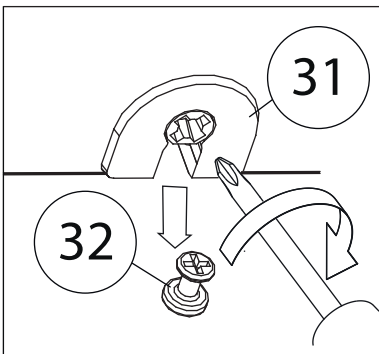

# 21

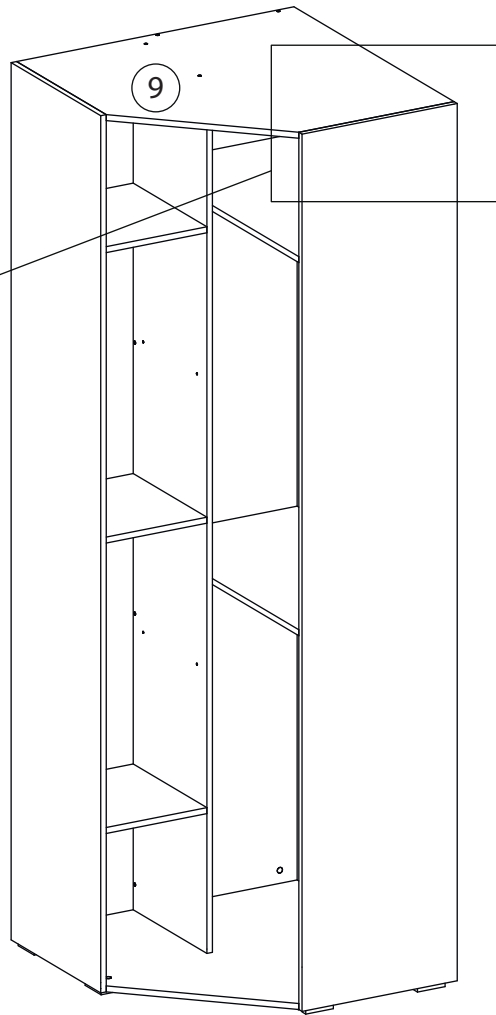
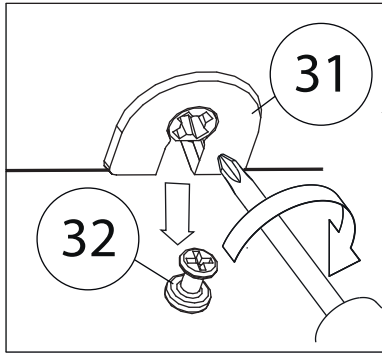

# 22

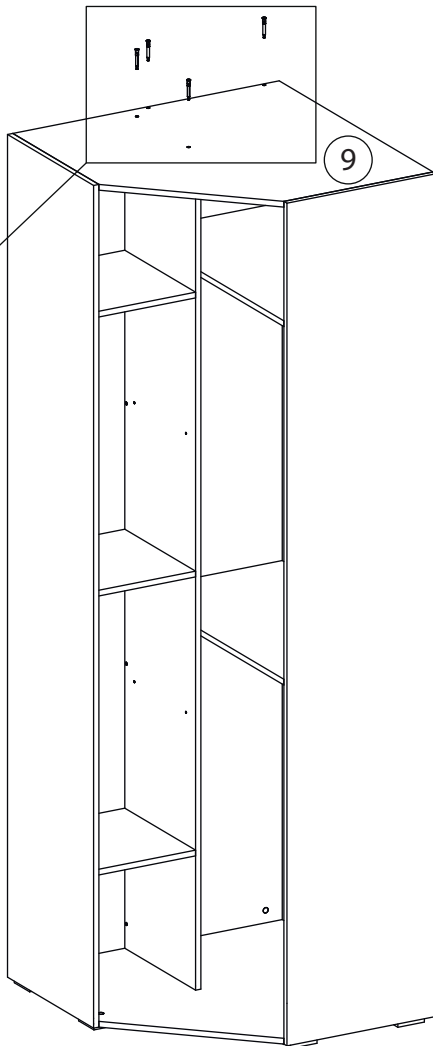
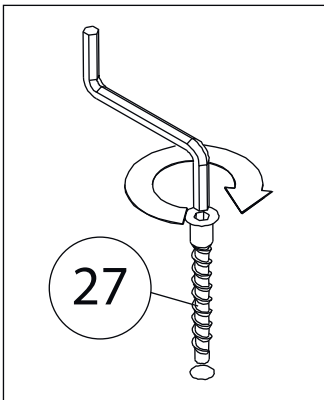

# 23

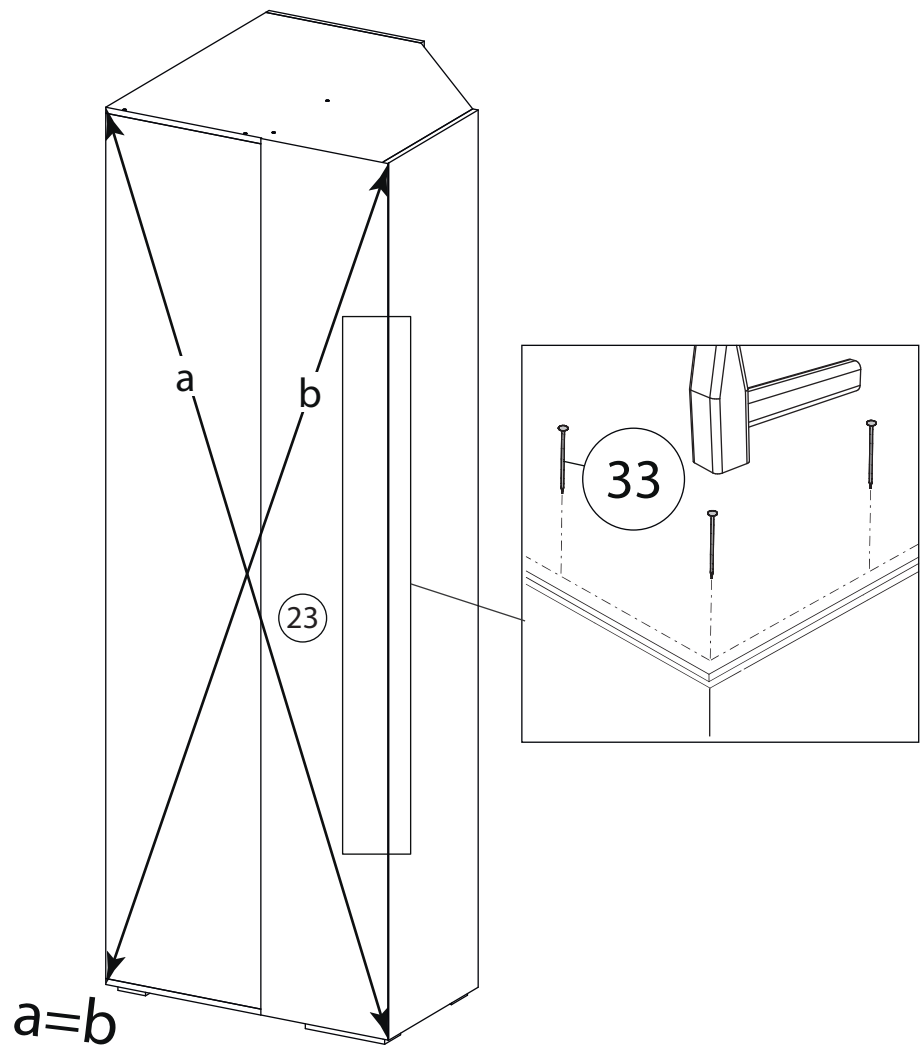

# 24

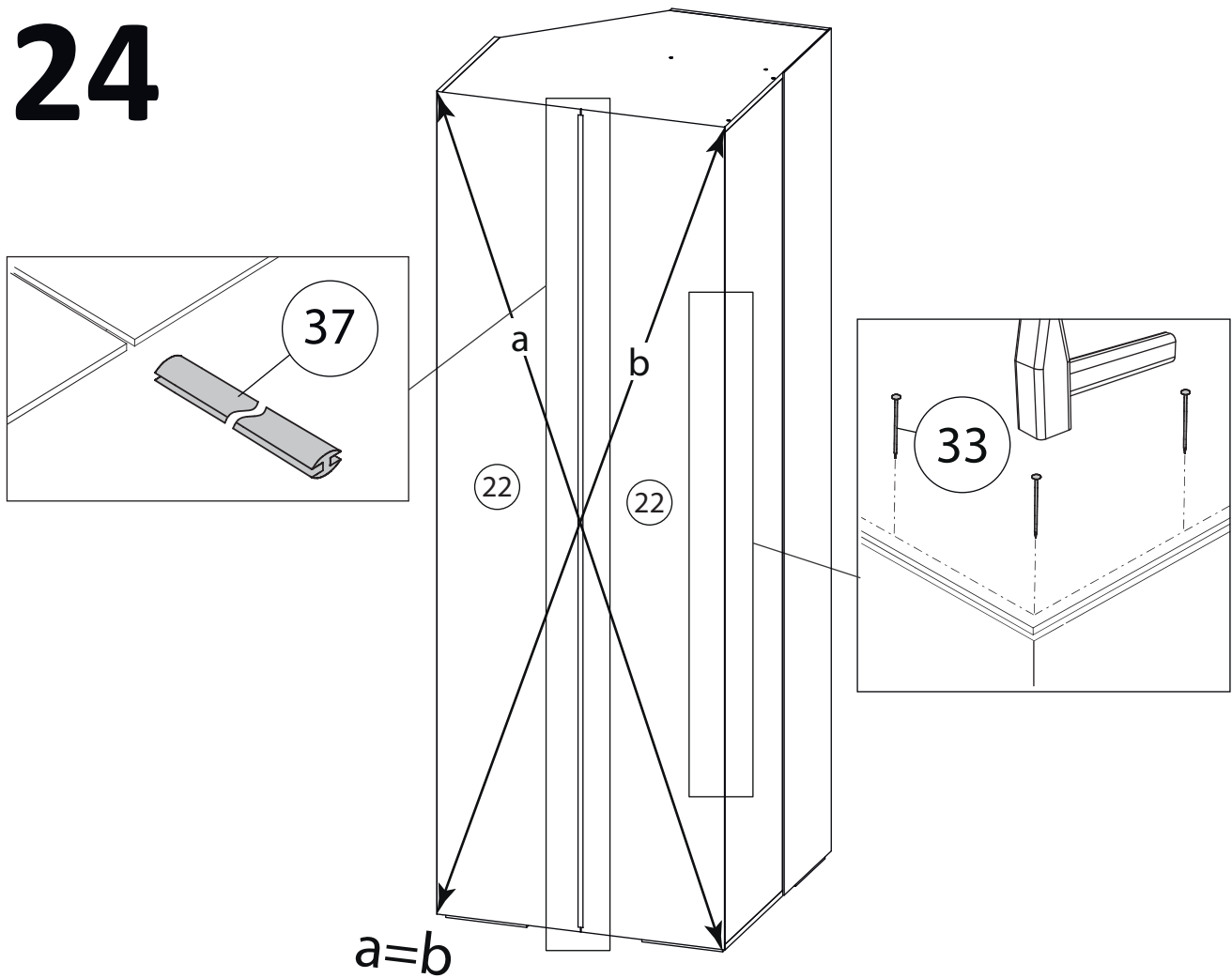

# 25

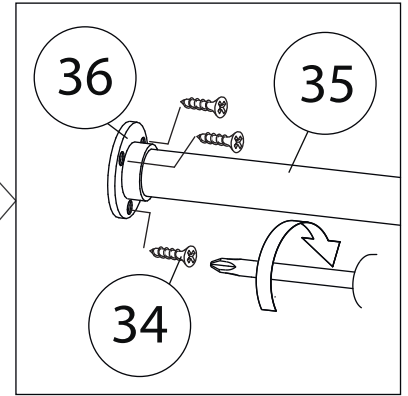
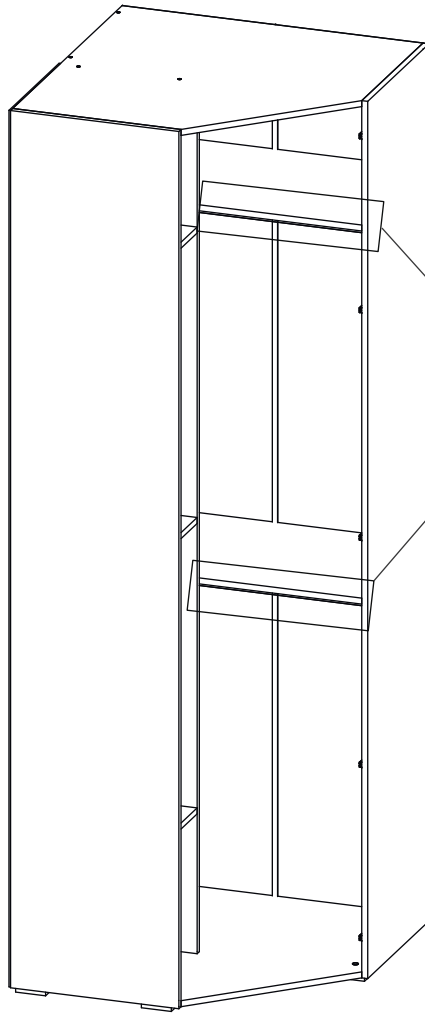

# 26

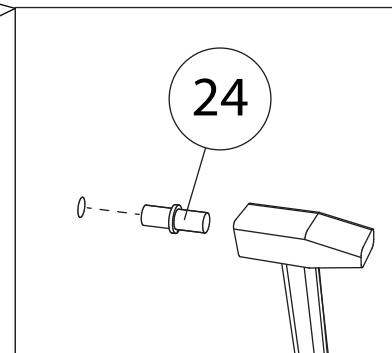
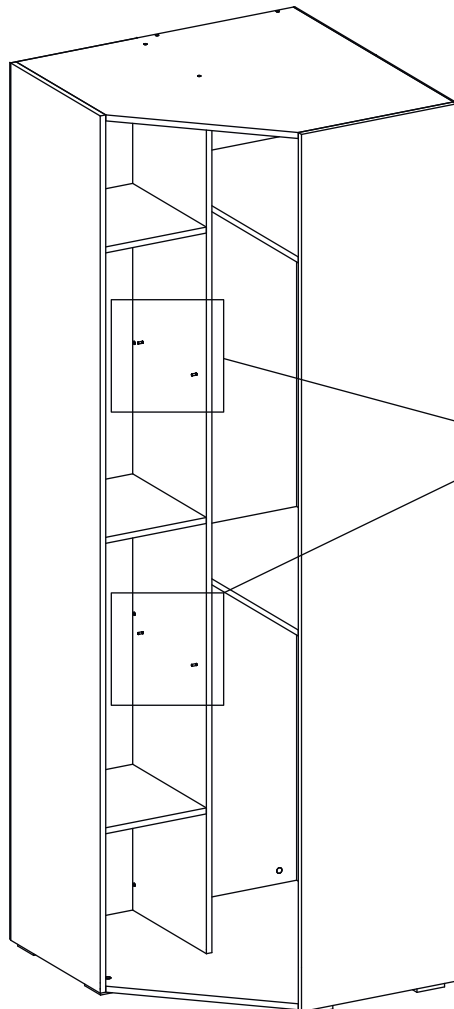

# 27

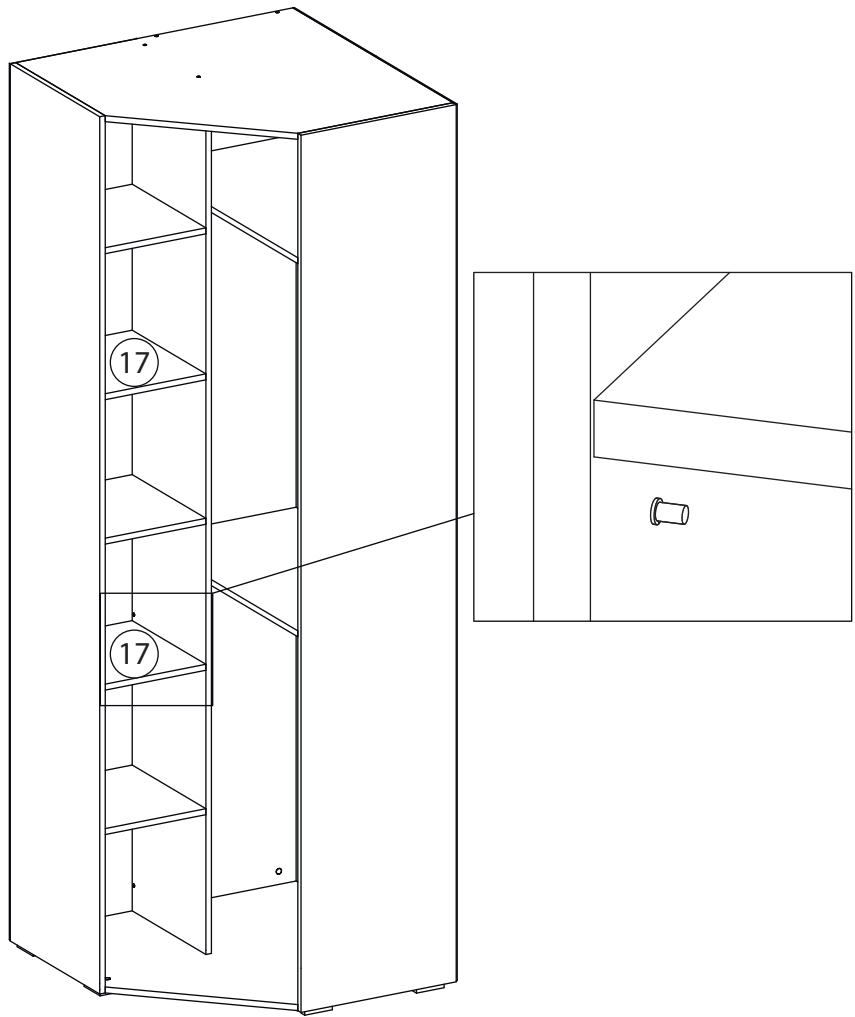

# 28

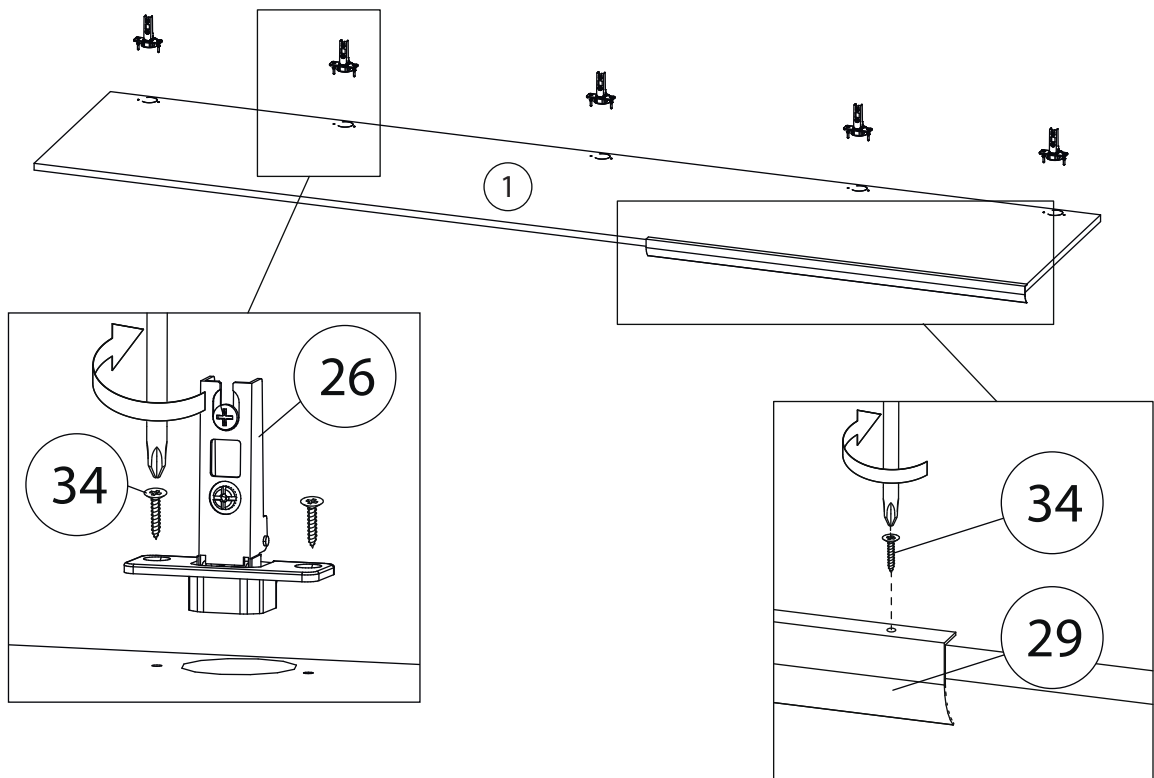

# 29

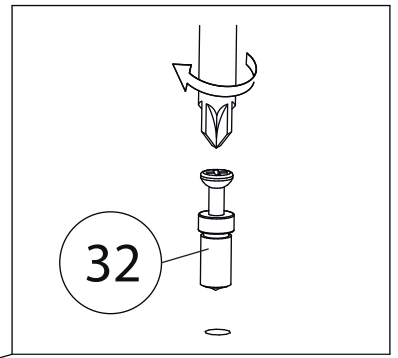
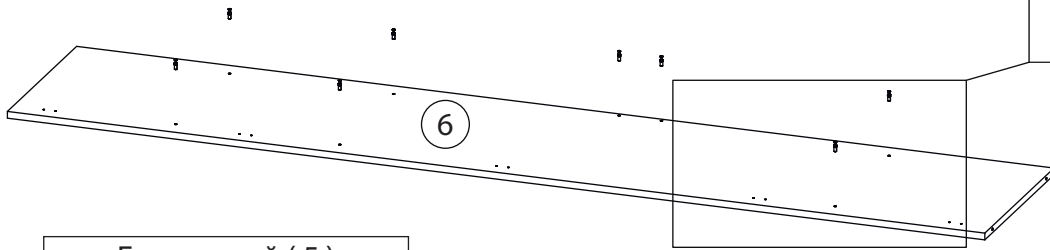

Бок правый ( 5 )  
собирается зеркально

# 30

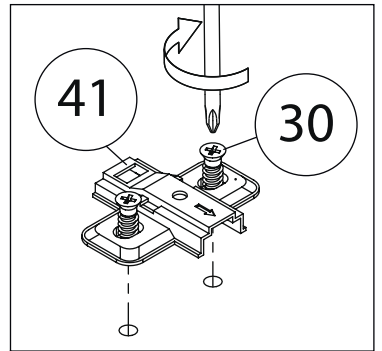
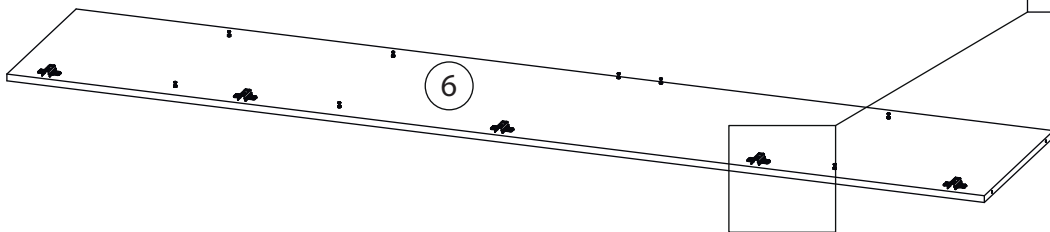

# 31

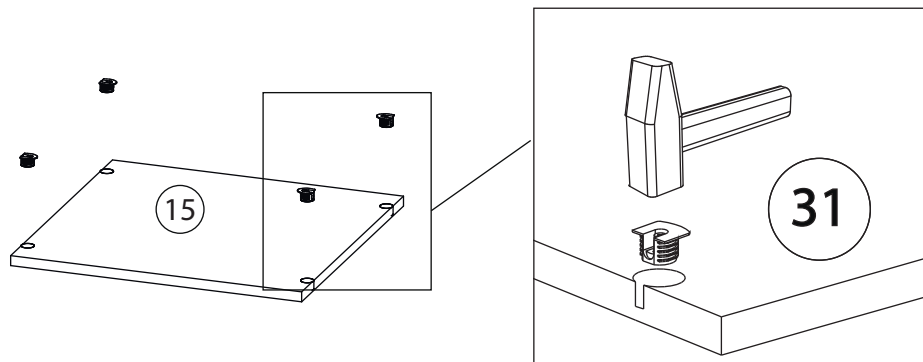

# 32

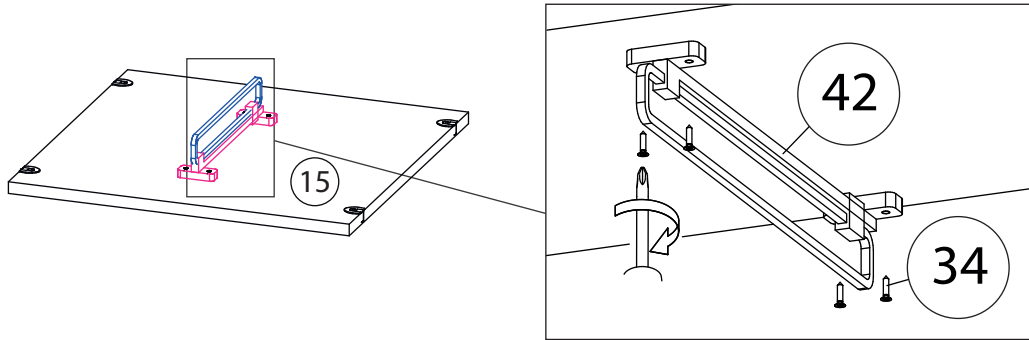

# 33

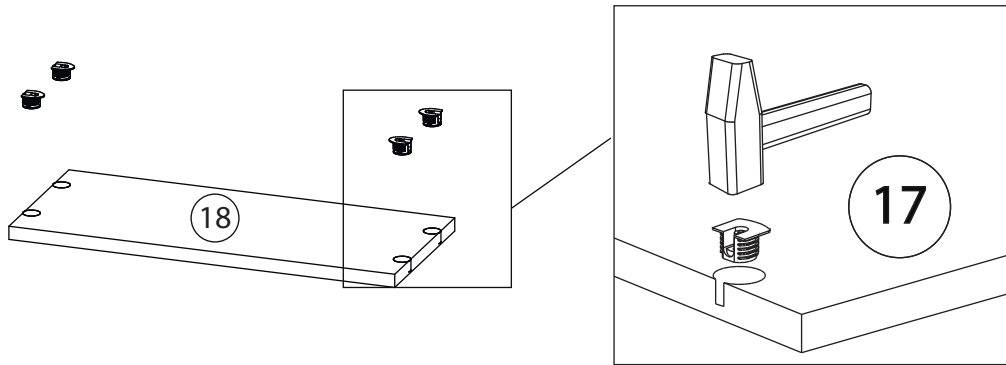

# 34

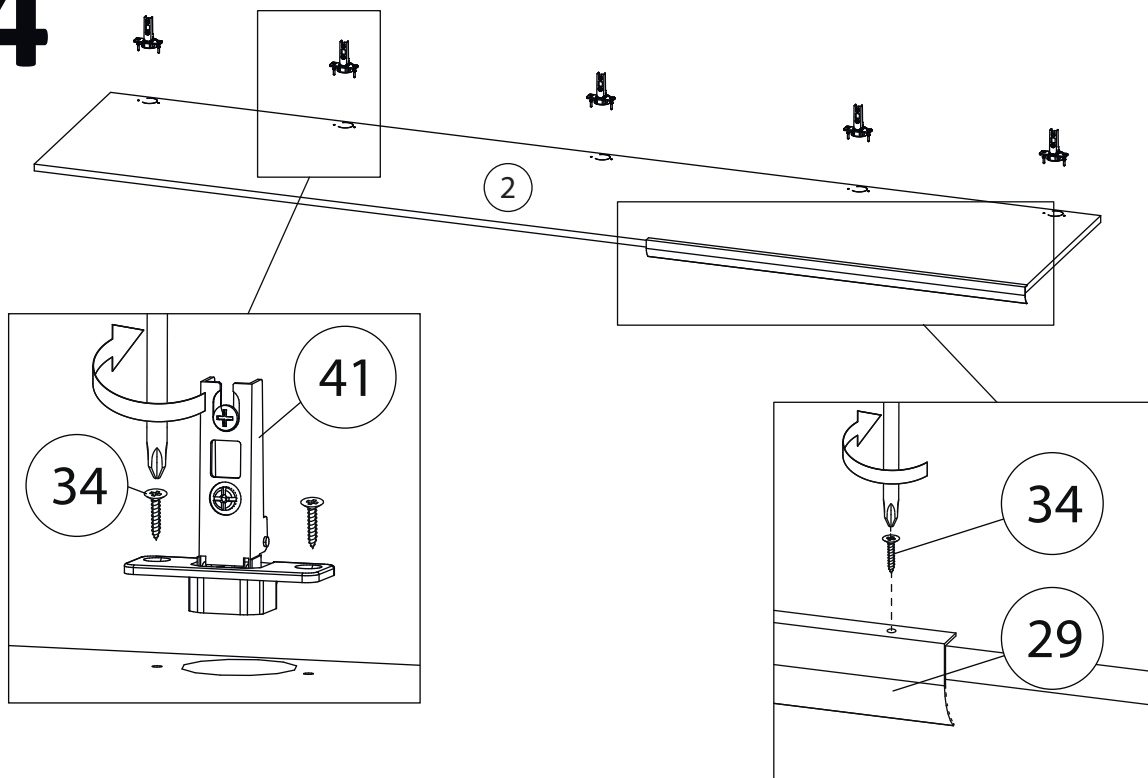

# 35

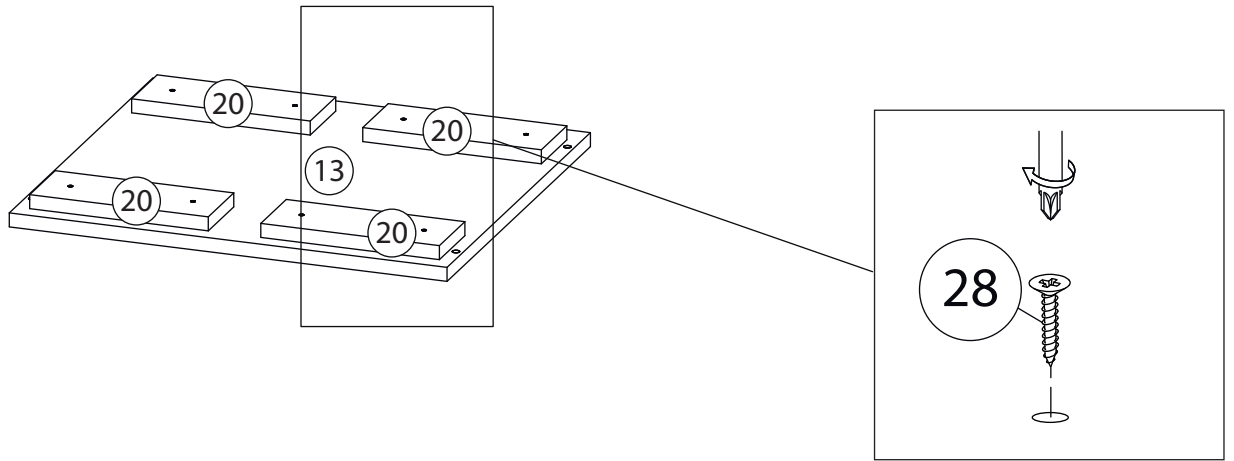

# 36

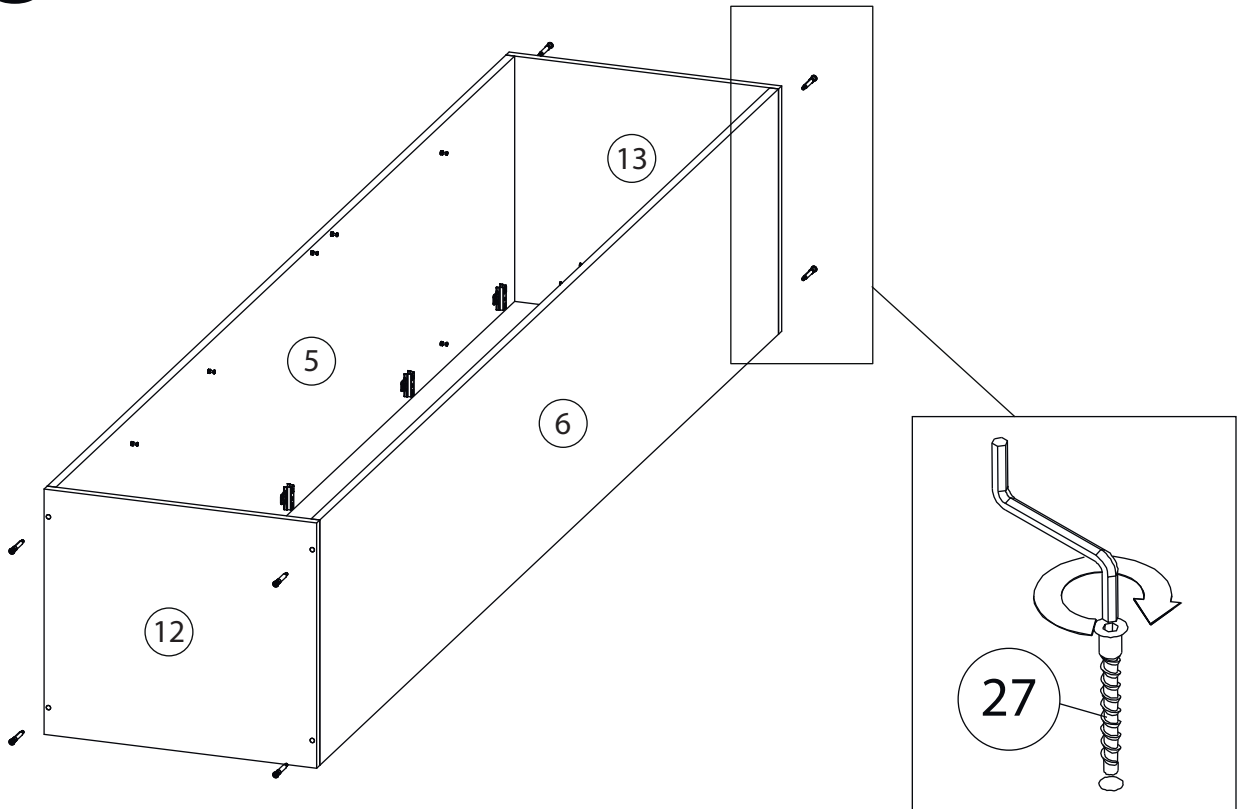

# 37

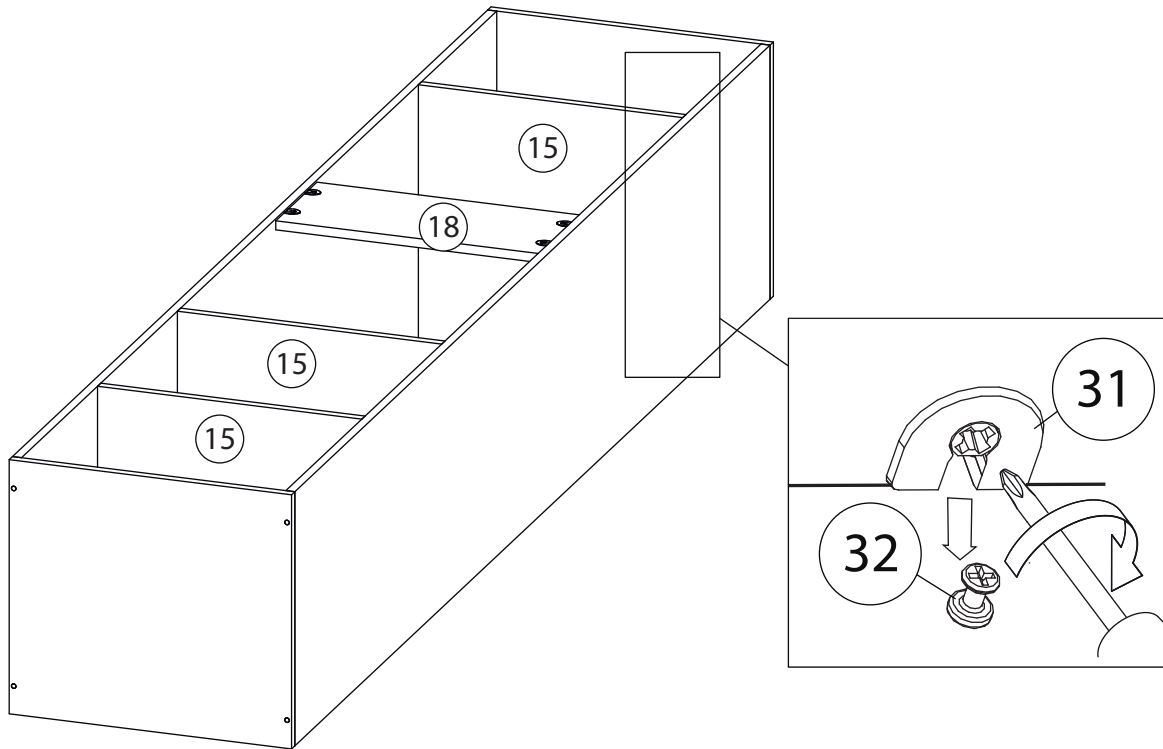

# 38

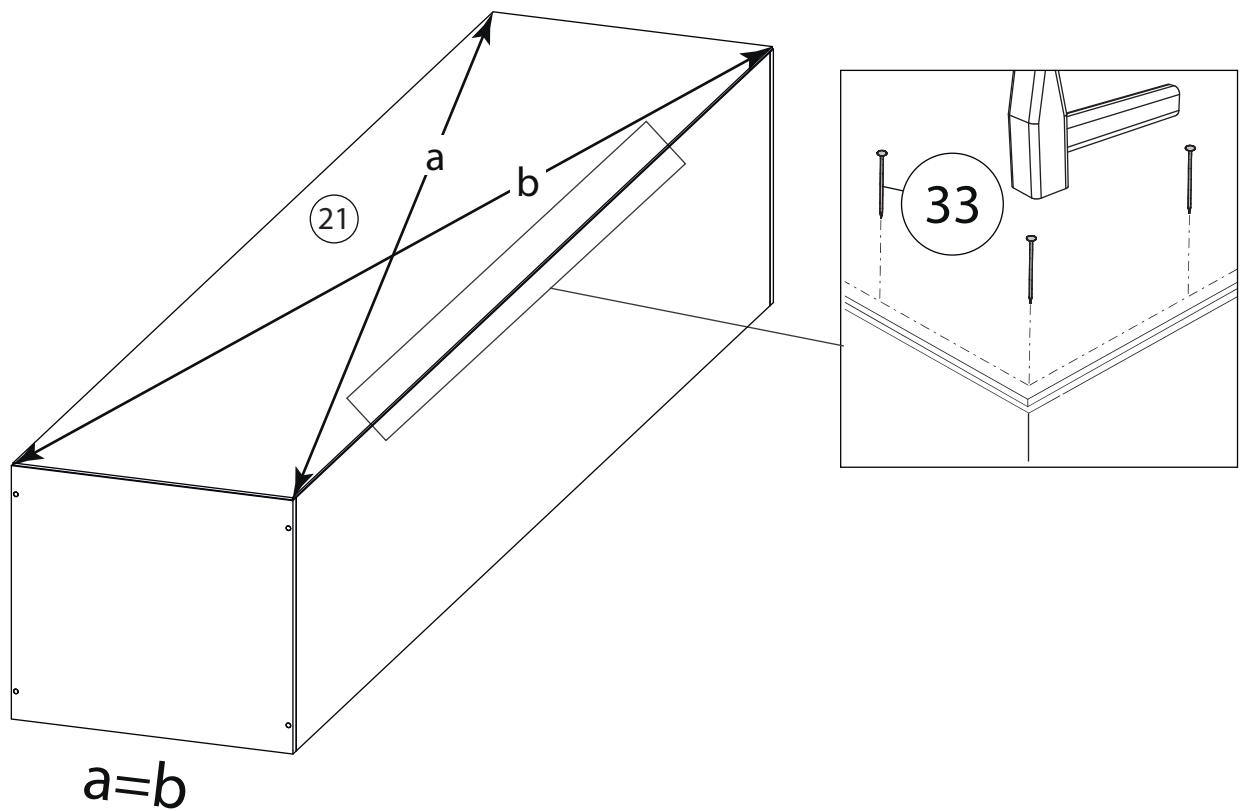

# 39

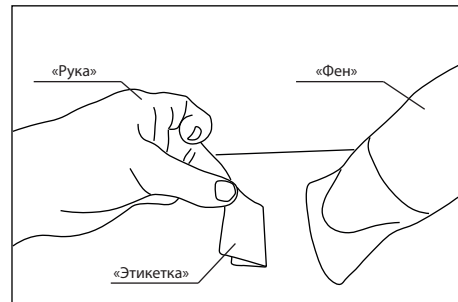

Удалить с детали этикетки со штрихкодом при помощи фена.

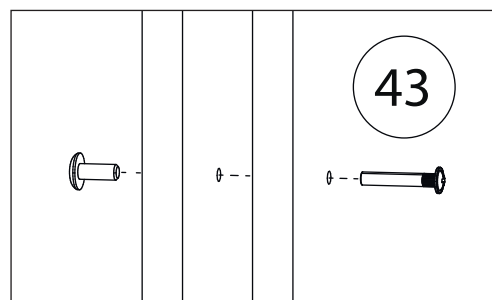
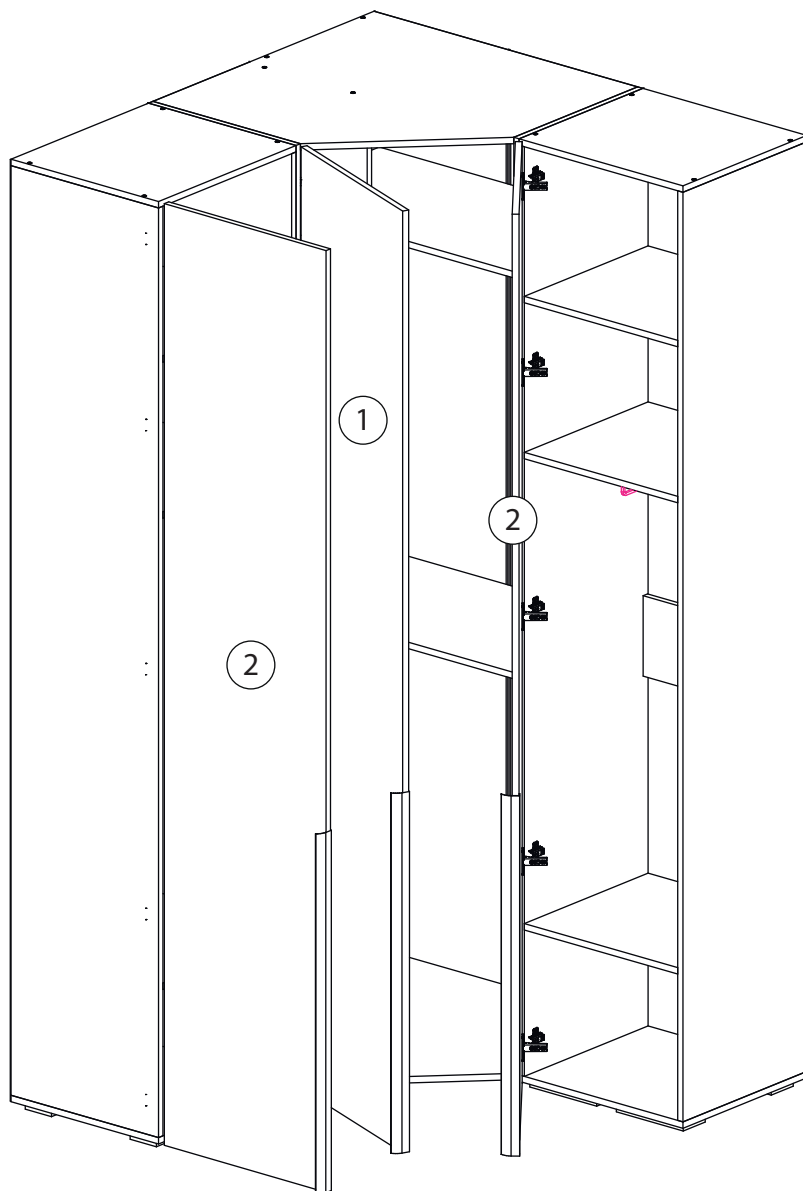

Два модуля стягиваются между собой межсекционными стяжками ( 43 ).  
Предварительно в соприкасающихся боковинах просверливаются сквозные отверстия диаметром 5мм, в произвольном месте, под стяжки

Заклеить технические отверстия заглушками.

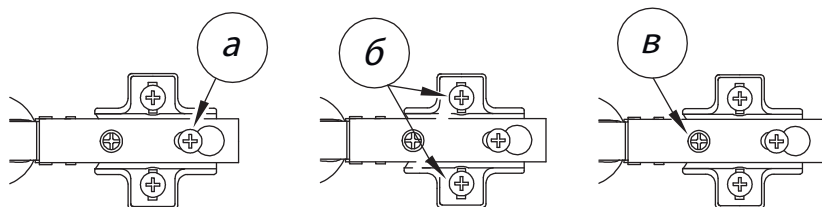

## Регулировка петель

а - регулировка расстояния между дверью и корпусом  
б - регулировка положения двери по-вертикали  
в - регулировка положения ТТдвери по-горизонтали