

Инструкция по сборке

Синтра

Шкаф распашной 2

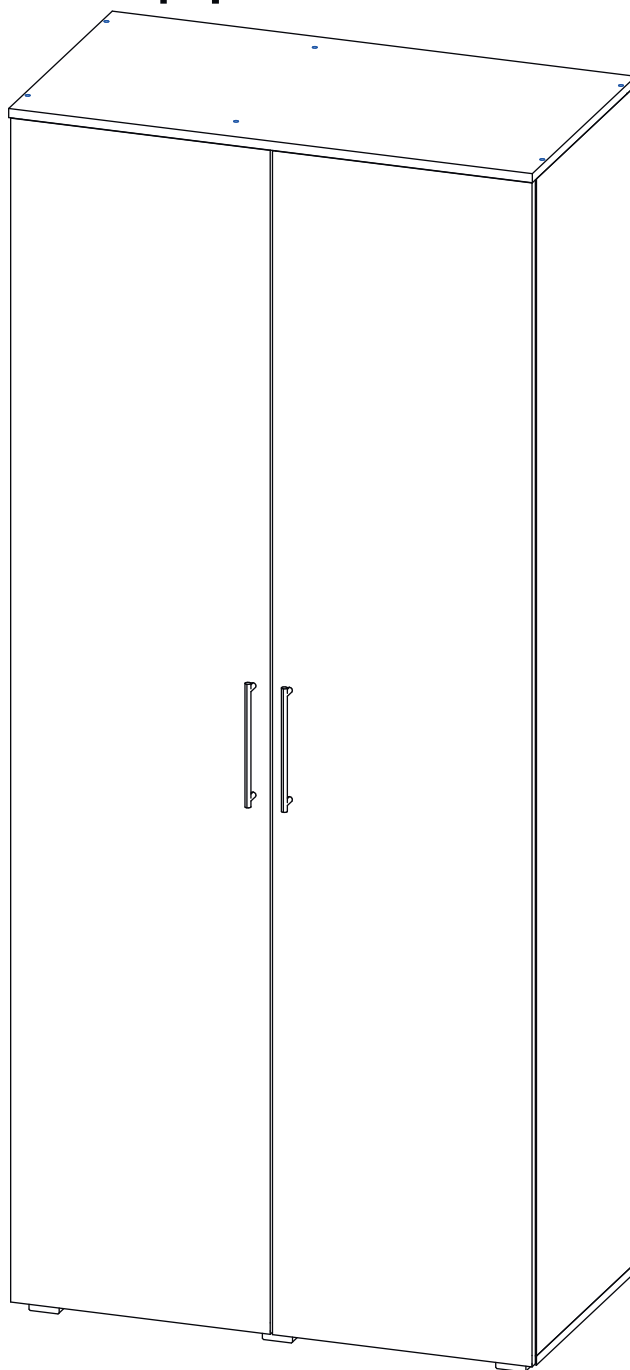





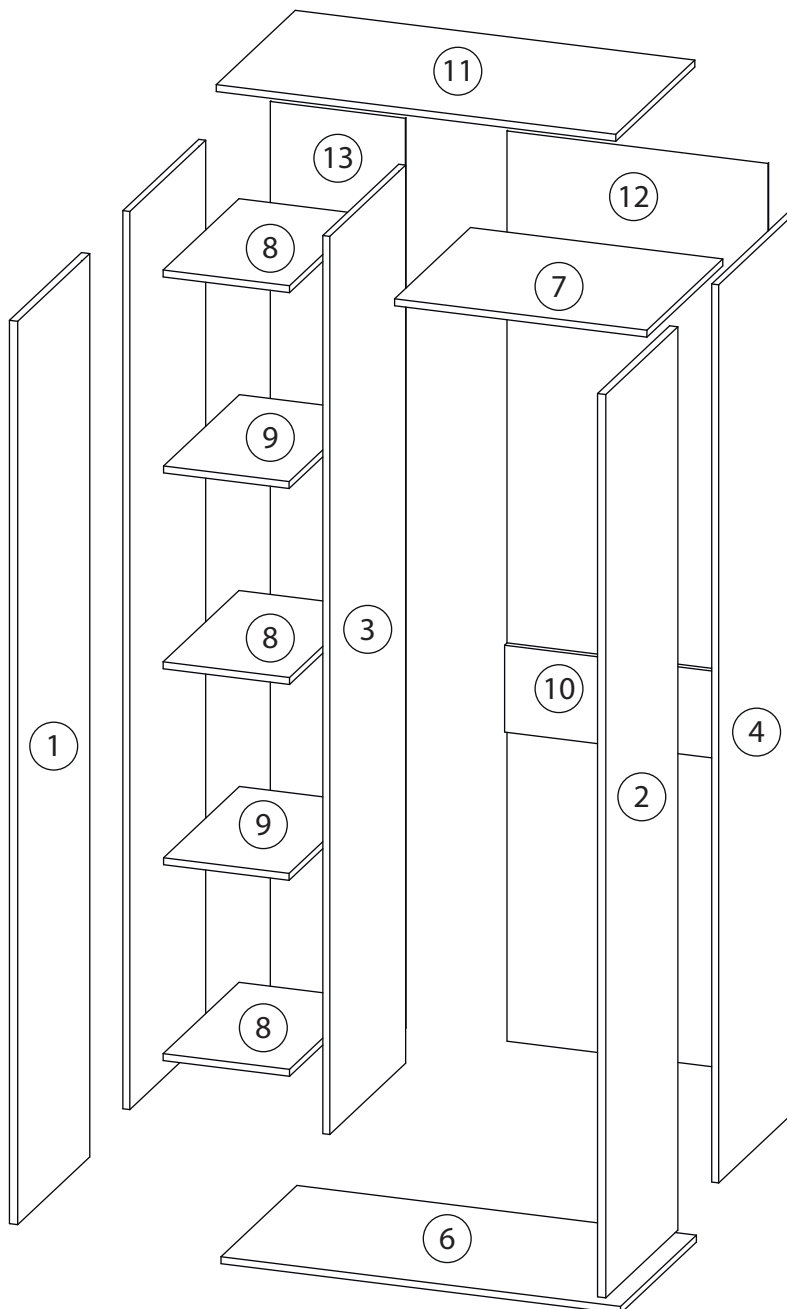

Детали

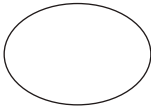
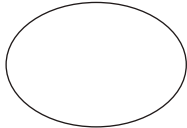
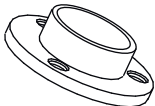
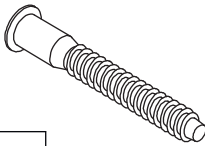
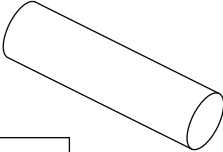
Поз.	Наименование	Кол-во	Длина	Ширина
1	Дверь2	1	2080	456
2	Дверь1	1	2080	456
3	Перегородка	1	2068	480
4	Бок правый	1	2068	480
5	Бок левый	1	2068	480
6	Дно	1	920	480
7	Полка	1	581	480
8	Полка	3	291	480
9	Полка	2	289	480
10	Ребро жесткост	1	581	200
11	Крыша	1	920	500
12	Задняя стенка	1	2096	601
13	Задняя стенка	1	2096	311

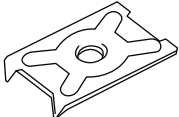

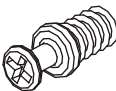
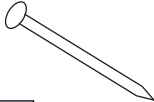
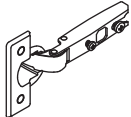
Фурнитура

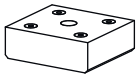
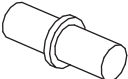
 14	 15	 16	 17	 18
<u>Заглушка</u> <u>Ø13</u>	<u>Заглушка</u> <u>Ø17-20</u>	<u>Штангодержатель</u>	<u>Евровинт 7x50</u>	<u>Штанга</u>
 19	 20	 21	 22	 23
<u>Саморез 3,5x16</u>	<u>Скоба для</u> <u>задней стенки</u>	<u>Ручка</u>	<u>Евровинт 6,3x13</u>	<u>Винт для стяжки</u> <u>VB35</u>
 24	 25	 26	 27	 28
<u>Гвоздь 1,6x25</u>	<u>Петля накладная</u>	<u>Стяжка VB35</u>	<u>Опора</u>	<u>Полкодержатель</u>

1

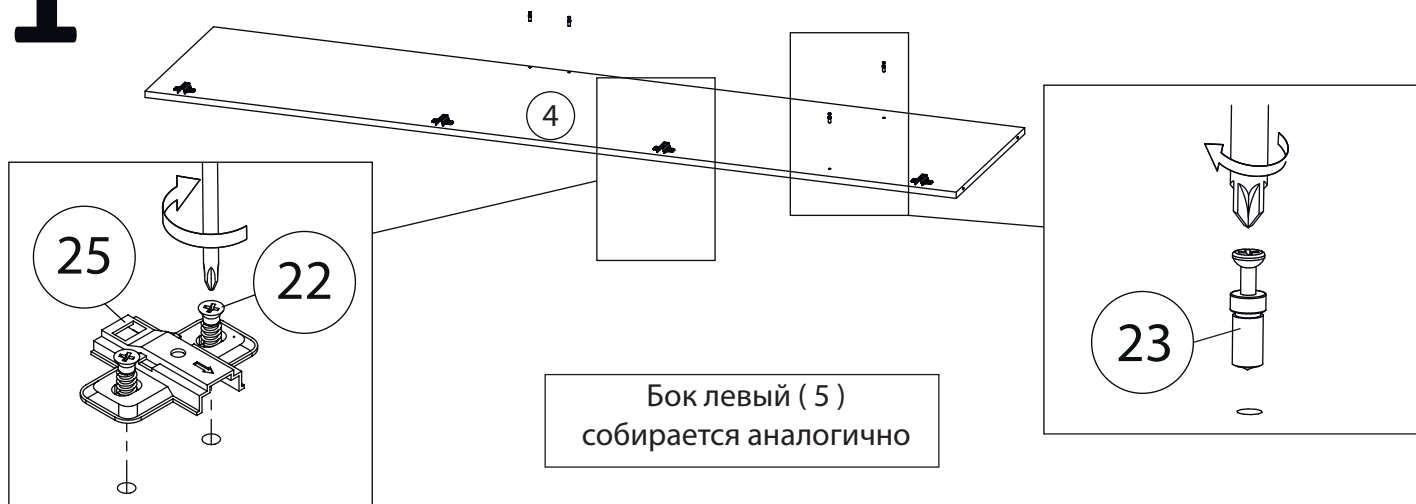

2

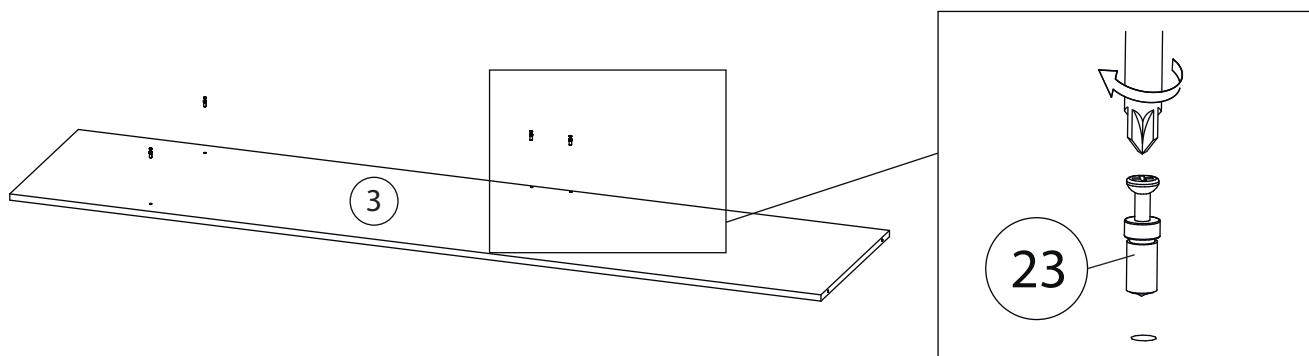

3

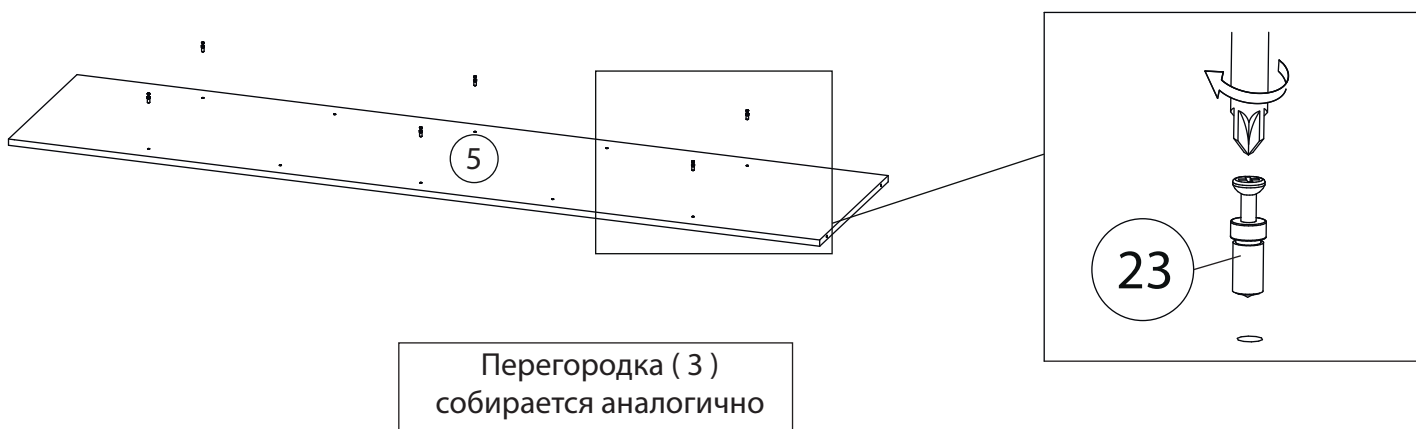

4

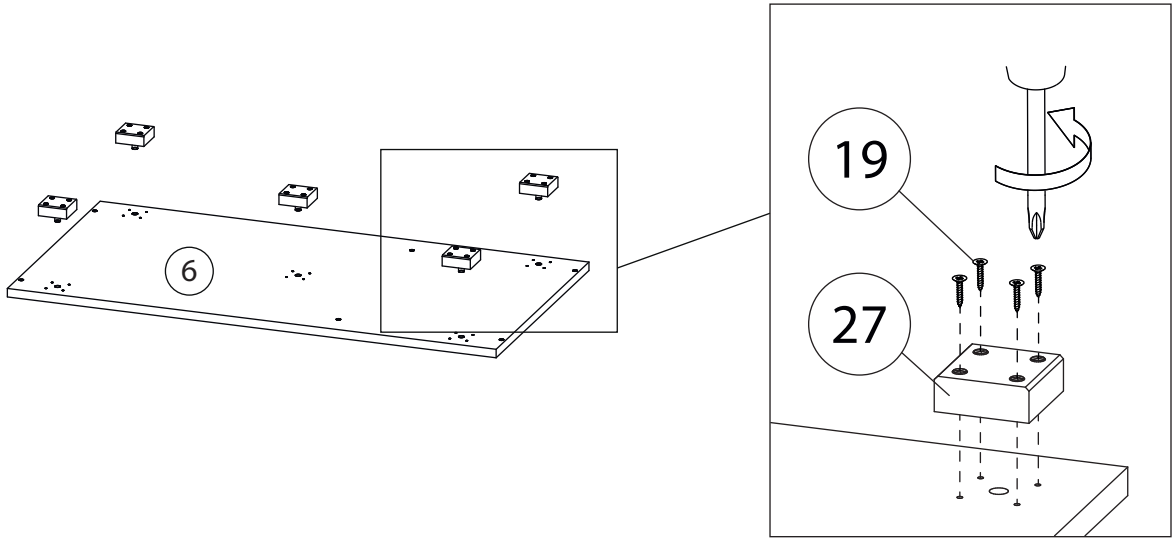

5

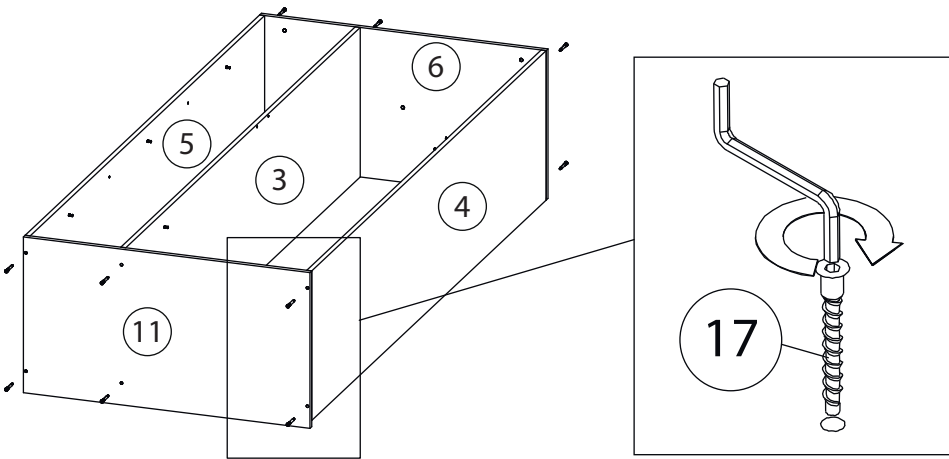

6

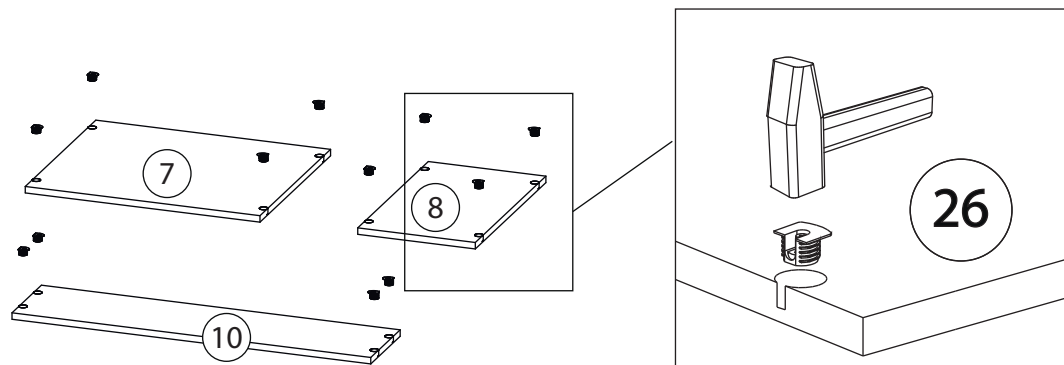

7

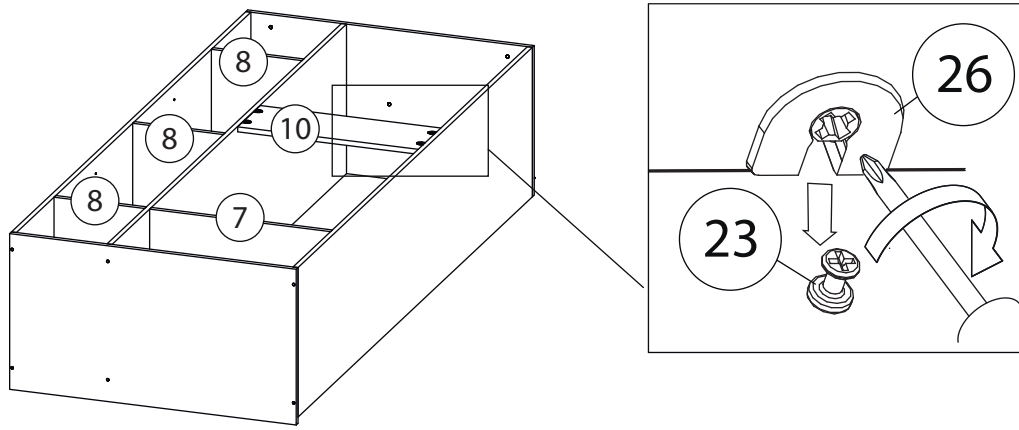

8

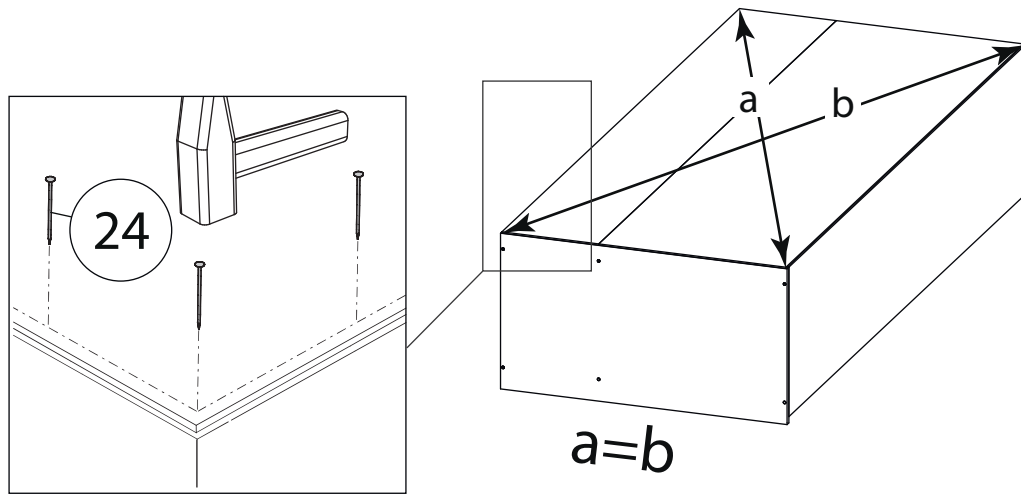

9

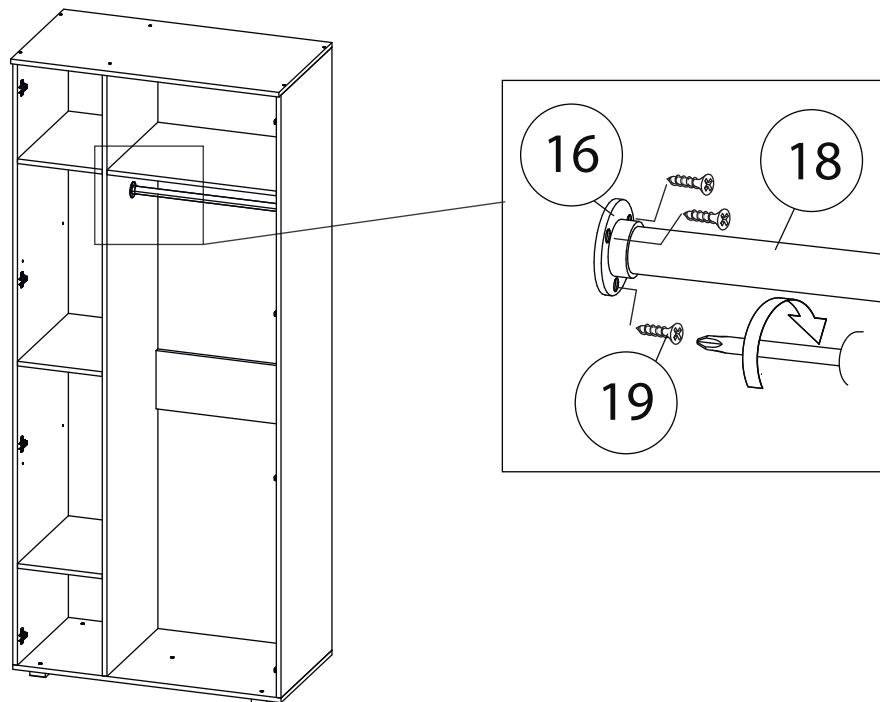

10

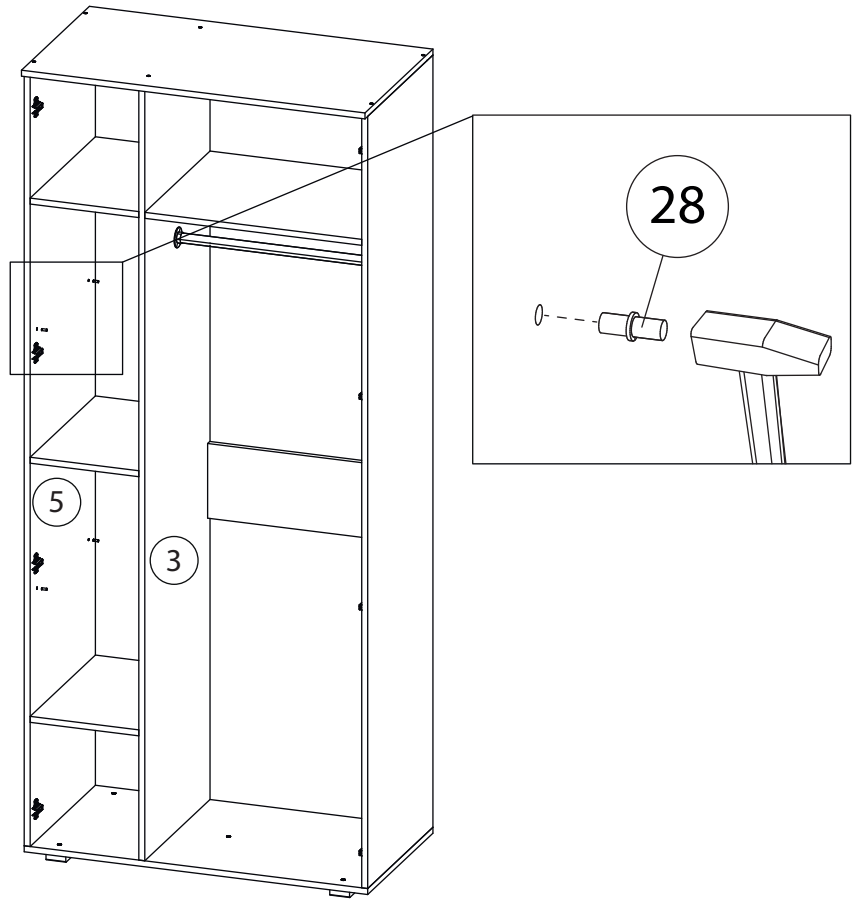

11

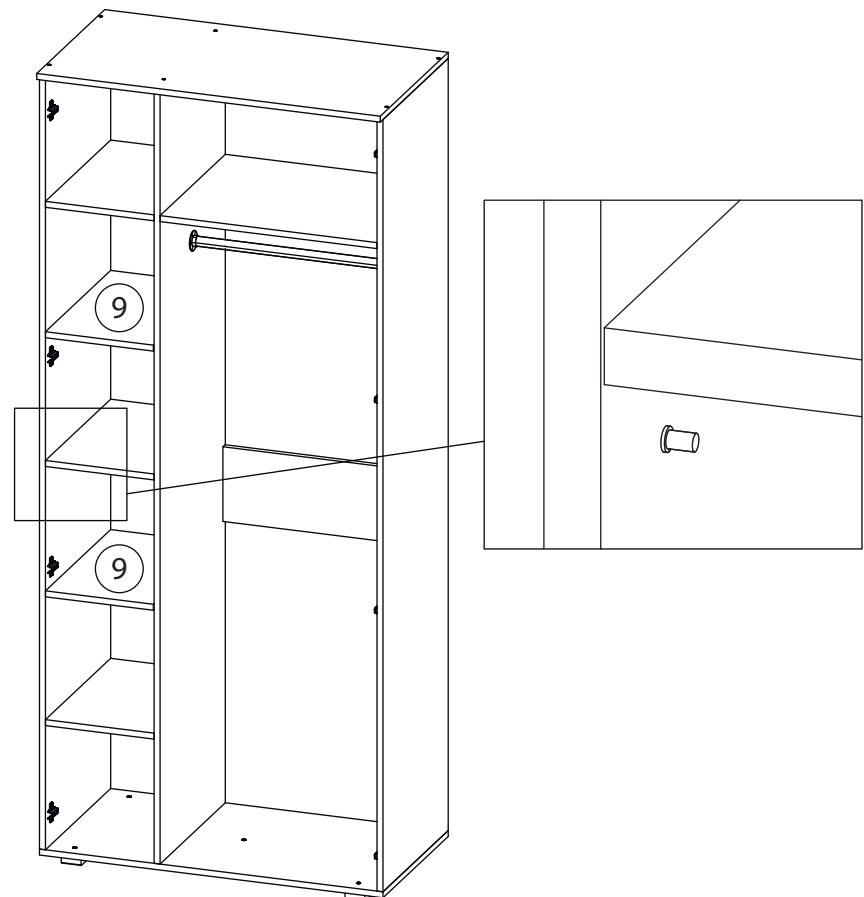

12

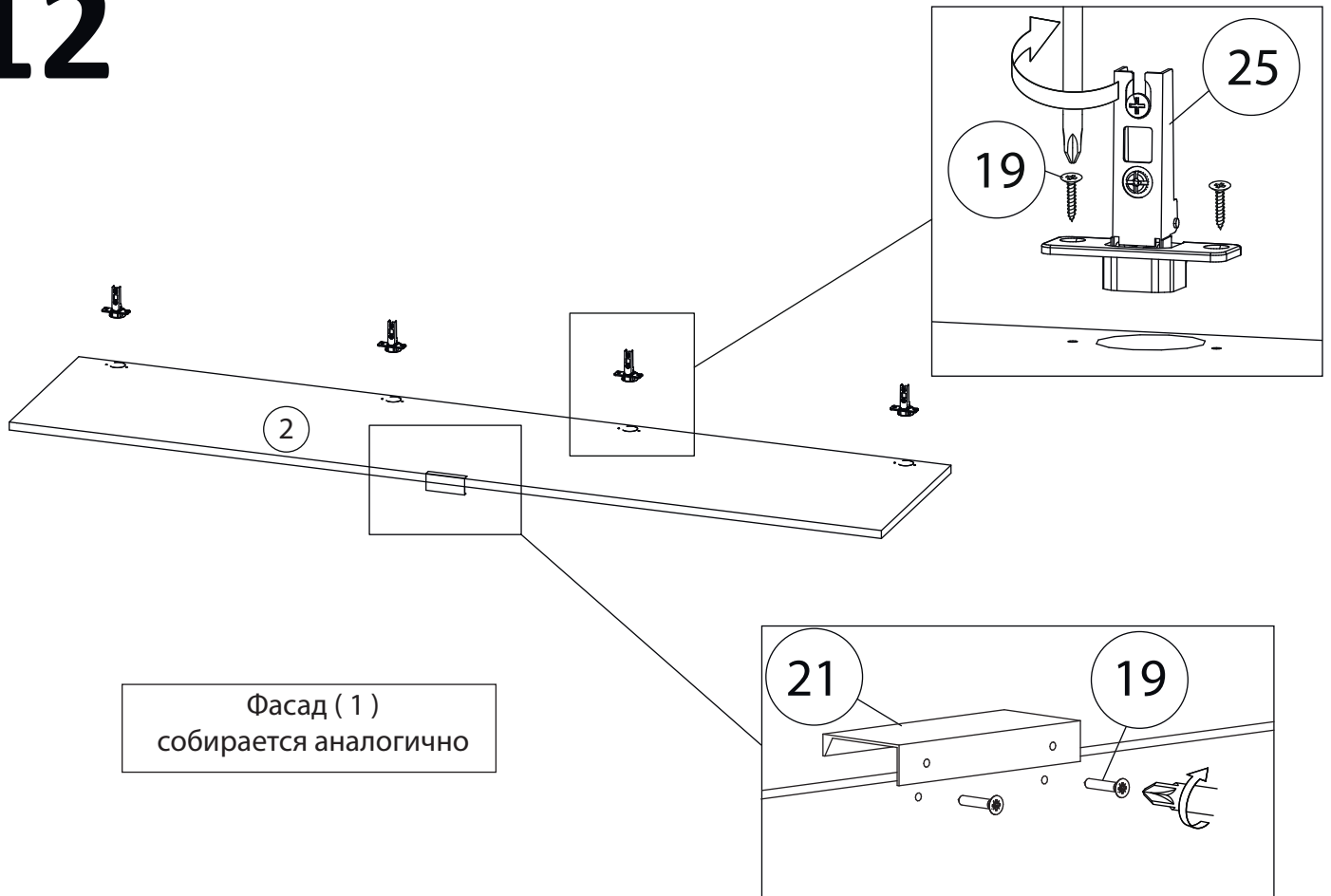

13

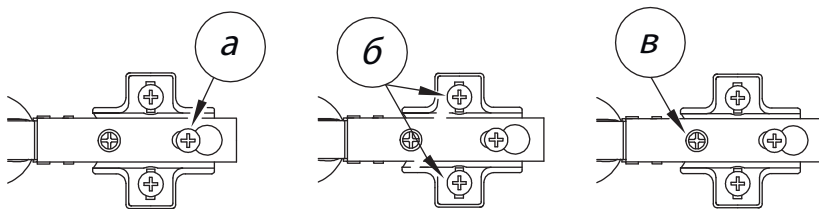

Регулировка петель
а - регулировка расстояния
между дверью и корпусом
б - регулировка положения
двери по-вертикали
в - регулировка положения
двери по-горизонтали

14

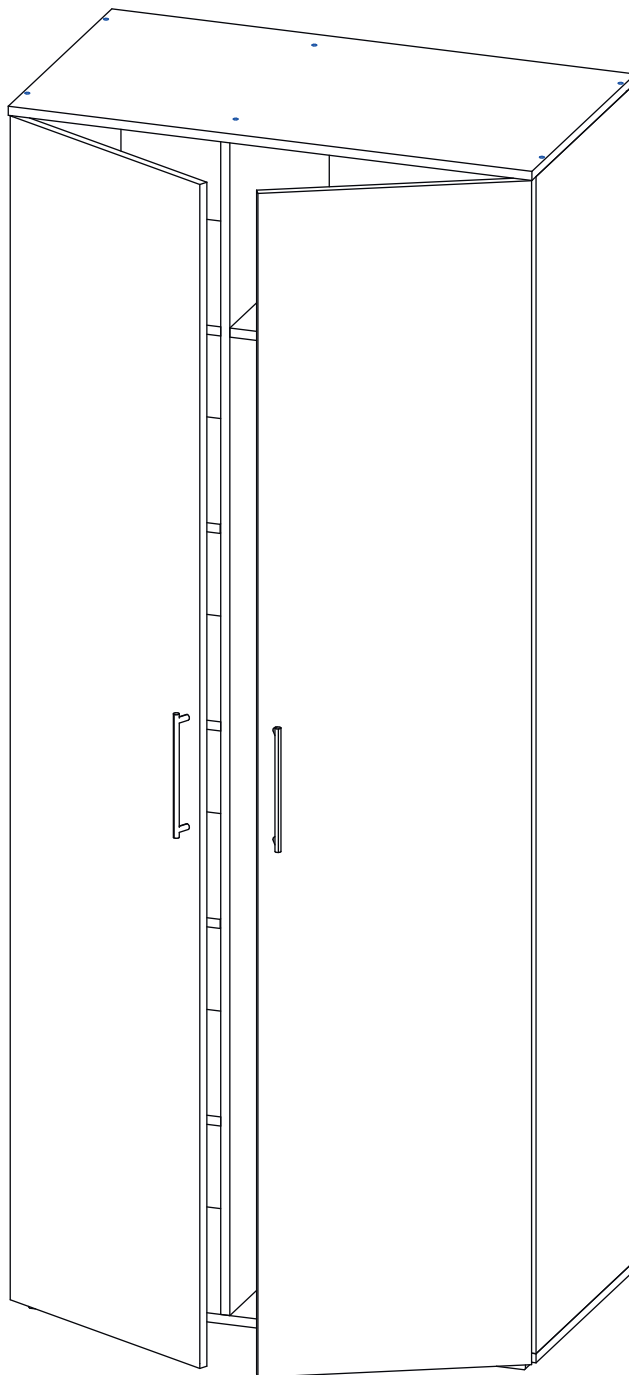
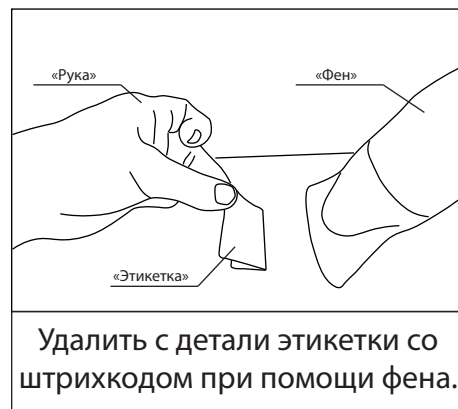
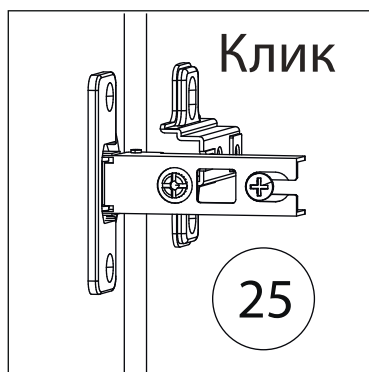

Заклеить технические отверстия заглушками.